



# ***The Giant Clam: Hatchery and Nursery Culture Manual***

Edited by Richard D. Braley



Australian Centre for International Agricultural Research  
Canberra 1992

The Australian Centre for International Agricultural Research (ACIAR) was established in June 1982 by an Act of the Australian Parliament. Its mandate is to help identify agricultural problems in developing countries and to commission collaborative research between Australia and developing country researchers in fields where Australia has a special research competence.

Where trade names are used this constitutes neither endorsement of nor discrimination against any product by the Centre.

#### **ACIAR MONOGRAPH SERIES**

This peer-reviewed series contains the results of original research supported by ACIAR, or material deemed relevant to ACIAR's research objectives. The series is distributed internationally, with an emphasis on the Third World.

© Australian Centre for International Agricultural Research, GPO Box 1571,  
Canberra, ACT 2601

Braley, R.D. ed., 1992. The giant clam: hatchery and nursery culture manual.  
ACIAR Monograph No. 15, 144 p.

ISBN 1 86320 070 3

Technical editing, design, typesetting, and layout by Arawang Information Bureau  
Pty Ltd, Canberra, Australia.

Printed by Goanna Print Pty Ltd.

---

## Contents

|          |   |           |  |  |  |
|----------|---|-----------|--|--|--|
|          | Preface   | 5         |  |  |  |
|          | Acknowledgments   | 6         |  |  |  |
| <b>1</b> | <b>Introduction</b>   | <b>7</b>  |  |  |  |
| <b>2</b> | <b>Site selection: technical and ecological considerations</b>  | <b>15</b> |  |  |  |
|          | 2.1 Hatchery and land nursery   | 15        |  |  |  |
|          | 2.2 Ocean nursery and growout   | 20        |  |  |  |
| <b>3</b> | <b>Site selection: economic considerations</b>  | <b>23</b> |  |  |  |
|          | 3.1 Markets for giant clams   | 23        |  |  |  |
|          | 3.2 Establishment costs   | 24        |  |  |  |
|          | 3.3 Operating costs   | 25        |  |  |  |
|          | 3.4 Profit  | 26        |  |  |  |
|          | 3.5 Discussion  | 27        |  |  |  |
| <b>4</b> | <b>Broodstock collection and holding</b>  | <b>29</b> |  |  |  |
|          | 4.1 Collecting broodstock from the field  | 29        |  |  |  |
|          | 4.2 Holding broodstock  | 36        |  |  |  |
|          | 4.3 Broodstock conditioning   | 39        |  |  |  |
| <b>5</b> | <b>Spawning</b>   | <b>41</b> |  |  |  |
|          | 5.1 Induced spawning  | 41        |  |  |  |
|          | 5.2 Spontaneous spawning  | 44        |  |  |  |
|          | 5.3 Collection and fertilization of eggs  | 45        |  |  |  |
|          | 5.4 Estimate of egg count   | 47        |  |  |  |
| <b>6</b> | <b>Larval rearing</b>   | <b>51</b> |  |  |  |
|          | 6.1 Hatching and larval rearing methods   | 51        |  |  |  |
|          | 6.2 Stocking rate for the hatching tanks  | 52        |  |  |  |
|          | 6.3 The selection method  | 52        |  |  |  |
|          | 6.4 Retrieving swimming veligers from selection and estimates of counts   | 57        |  |  |  |
|          | 6.5 Stocking rate for the larval rearing tanks  | 58        |  |  |  |
|          | 6.6 Checking on swimming larvae   | 59        |  |  |  |
| <b>7</b> | <b>Larval feeding</b>   | <b>61</b> |  |  |  |
|          | 7.1 Algae   | 61        |  |  |  |
|          | 7.2 Yeast   | 68        |  |  |  |
|          | 7.3 Microencapsulated diets   | 68        |  |  |  |
|          | 7.4 Zooxanthellae   | 70        |  |  |  |
| <b>8</b> | <b>Larval settlement and metamorphosis to juveniles</b>   | <b>73</b> |  |  |  |
|          | 8.1 Estimating the numbers of settled pediveligers in the larval culture tank and stocking them into land nursery tanks | 73        |  |  |  |
|          | 8.2 Sampling in nursery tank to estimate survival   | 77        |  |  |  |
|          | 8.3 Zooxanthellae addition after settlement   | 77        |  |  |  |
|          | 8.4 Use of shadecloth over tanks  | 78        |  |  |  |
| <b>9</b> | <b>Land nursery phase</b>   | <b>79</b> |  |  |  |
|          | 9.1 Cleaning of algal fouling on tank bottom  | 79        |  |  |  |
|          | 9.2 Seawater  | 83        |  |  |  |

|     |  |     |    |   |     |
|-----|--|-----|----|---|-----|
| 9.3 | Nutrient addition  | 84  | 13 | <b>Quarantine protocol for the import of glant clams</b>                              | 121 |
| 9.4 | Greenhouse heating in combination with recirculating system            | 85  |    | 13.1 Why have a protocol?   | 121 |
| 9.5 | Volumetric count estimate from land nursery phase before transfer      | 86  |    | 13.2 Aims of quarantine in the importing country                                      | 121 |
| 10  | <b>Genetics In culture</b>   | 89  |    | 13.3 Protocol for importing country   | 122 |
| 11  | <b>Diseases, parasites and pests</b>                                   | 91  |    | 13.4 Criteria for the release of imported clams into the local marine environment     | 126 |
| 12  | <b>Quarantine protocol for the export of glant clams</b>               | 109 |    | <b>References</b>   | 129 |
|     | 12.1 Why have a protocol?  | 109 |    | <b>Appendix</b>   |     |
|     | 12.2 Principles of quarantine protocol                                 | 109 |    | Equipment needed to set up a hatchery and farm, estimated costs and sources of supply | 135 |
|     | 12.3 Protocol for exporting country                                    | 111 |    |   |     |
|     | Appendix: Form of declaration that export protocol has been adhered to | 117 |    |   |     |

---

## **Preface**

The giant clam represents a traditional food source for the people of the Indo-Pacific region. The demand for the meat or shells, coupled with the over-exploitation by Taiwanese boats have decimated and locally exterminated populations of some species. Thus, in the 1970s and 1980s, research into the reproduction and larval culture of giant clams became important. The Micronesian Mariculture Demonstration Center (MMDC) in Palau played a key role in moving mariculture of giant clams from the laboratory to mass culture. The University of Papua New Guinea (Motupore Island Research Centre) was likewise involved in giant clam larviculture, but on a smaller scale than the MMDC. In the early to mid 1980s, Australia became involved with giant clam mariculture, first in a small government-funded project through the University of New South Wales and then in a separate large project funded by the Australian Centre for International Agricultural Research (ACIAR) and administered by James Cook University of North Queensland. The ACIAR-funded giant clam project began with Australia, Fiji, Philippines and Papua New Guinea but by Phase II in the late 1980s it included Tonga, Cook Islands, Kiribati and Tuvalu, while losing Papua New Guinea. Also, in the late 1980s, the International Centre for Living Aquatic Resources Management (ICLARM) set up a coastal aquaculture centre near Honiara, Solomon Islands in which giant clams are the main organism being cultured. Other hatcheries and ocean nurseries have been started, notably in Micronesia and most recently in Tonga and Cook Islands.

The markets for giant clams are at present almost exclusively in Asia and the Pacific islands. The demand is for adductor muscle, mantle (fresh, dried, frozen) and shells. Although more work is required on marketing aspects, the general indication for future development and expansion of giant clam cultivation is positive.

This manual provides a guide to the practicalities of giant clam aquaculture. It deals with hatchery and land nursery operations (see Figure 1.1, page 8). A companion manual, also published by ACIAR, details the ocean nursery culture of the giant clams.

---

## Acknowledgments

Major contributors to the preparation of this manual were:

|                 |  |
|-----------------|--|
| Dr Rick Braley  | James Cook University of North Queensland, Australia |
| Dr John Norton  | Oonoonba Veterinary Laboratory, Australia            |
| Dr Clem Tisdell | University of Queensland, Australia                  |
| Dr John Benzie  | Australian Institute of Marine Science, Australia.   |

Contributions were also made by:

|                        |   |
|------------------------|---|
| Dr Ed Gomez            | Marine Science Institute, University of the Philippines |
| Dr Suzanne Mingoa      | Marine Science Institute, University of the Philippines |
| Dr Hilconida Calumpang | Silliman University Marine Laboratory, Philippines      |
| Mr Esaroma Ledua       | Fisheries Division, Fiji                                |
| Mr Naita Manu          | Fisheries Department, Tonga                             |
| Ms Dorothy Munro       | Ministry of Marine Resources, Cook Islands              |
| Ms Tooti Tekinaiti     | Fisheries Division, Kiribati.                           |

Ms Katrina Miller, Ms Jayne Kennedy, Dr Rick Braley, Dr Paul Southgate, and ACIAR staff were responsible for photography and initial drawings. Thanks are also due to Associate Professor John S. Lucas and Mr Jeremy Barker for their input, to Mrs Alison Ambrey and Mrs Sheryl Giles for assistance with final stages of preparation and for producing the equipment and supplier list, and to Mr Peter Lynch, ACIAR Publications Manager for organising the final production.

Finally, thanks go to all project leaders and staff of the ACIAR-funded 'Giant Clam Project' (ACIAR Project Nos 8332 and 8733) whose research and results made possible the preparation of this manual.

---

## Introduction

Giant clams are amenable to cultivation: the stages involved are shown in Figure 1.1. Their short larval period and relatively low dependence on phytoplankton (the usual food of bivalve molluscs) after settlement, coupled with their rapid growth after the first year, make them as suitable for cultivation as oysters and scallops. Their most significant attribute is the symbiosis with a dinoflagellate algae or zooxanthellae. The zooxanthellae live in the body of the clam, primarily in a tertiary extension of the gut with its extensive canals near the surface of the mantle tissue (John Norton, pers. comm.; 1991), not, as is commonly believed, in the circulatory system. In the shallow tropical waters the sunlight reaches the clam's mantle surface and photosynthesis occurs. The products of photosynthesis are mainly simple sugars but some protein and fats are also produced. These products are utilised by the clam to grow and to develop gonadal products for its reproduction. The zooxanthellae in turn have a receptacle in which to grow and reproduce. The giant clam can truly be described as a solar animal, although juvenile clams may have considerable heterotrophic requirements.

There are eight extant species of giant clam (Family Tridacnidae) within two genera:

*Tridacna gigas* (Figure 1.2), the true giant clam;

*Tridacna derasa* (Figure 1.3), the smooth-shell giant clam;

*Tridacna squamosa* (Figure 1.4), the fluted or scaly clam;

*Tridacna maxima* (Figure 1.5), the rugose giant clam or the small giant clam;

*Tridacna crocea* (Figure 1.6), the boring or crocus clam;

*Tridacna tevoroa* (Figure 1.7), the deep water devil clam;

*Hippopus hippopus* (Figure 1.8), the horse's hoof, bear paw or strawberry clam;

*Hippopus porcellanus* (Figure 1.9), the China clam.

# HATCHERY AND NURSERY CULTURE OF GIANT CLAMS

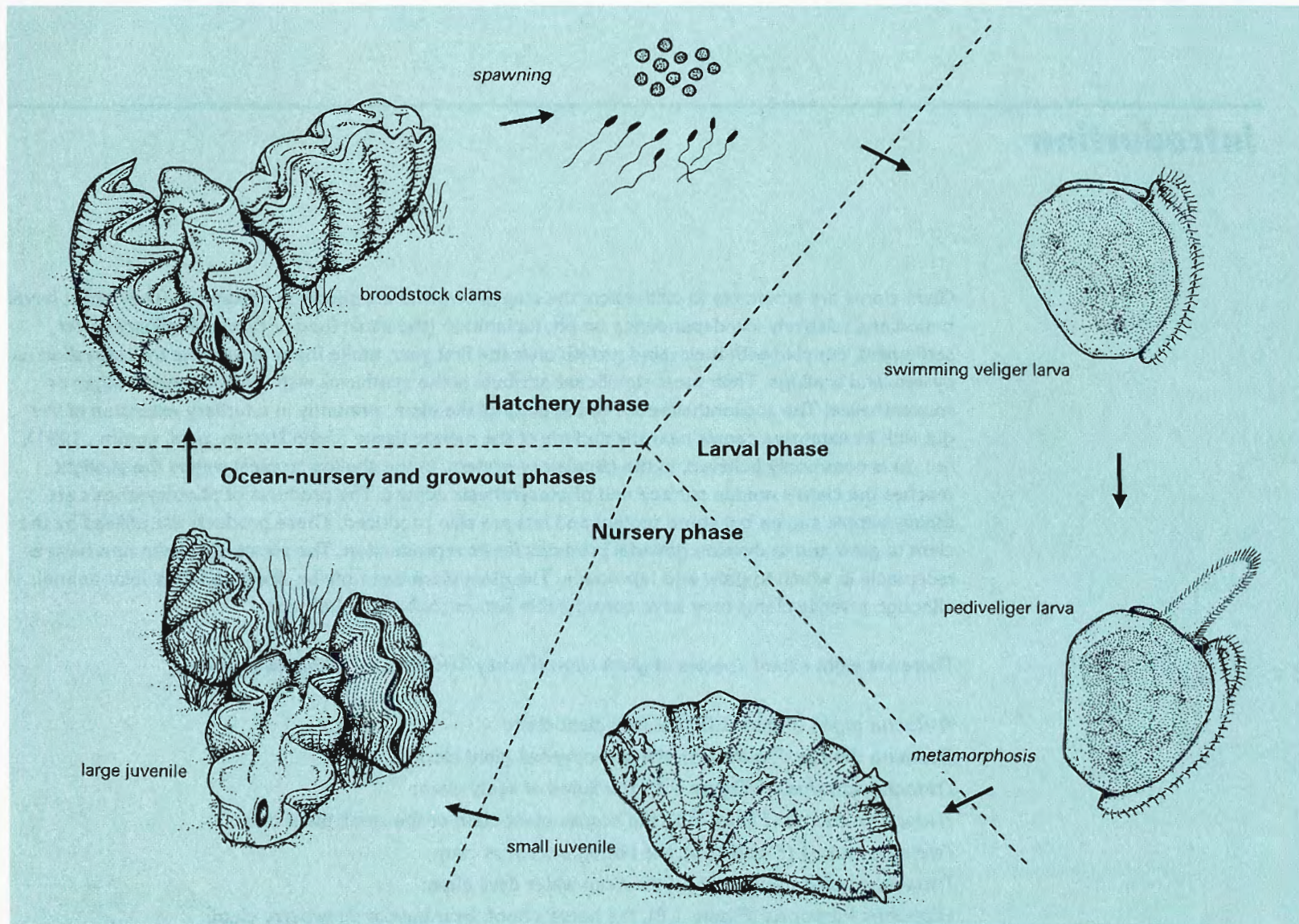


Figure 1.1 Phases of giant clam aquaculture



A key to the giant clams can be found in Rosewater (1965, 1982) and in the ACIAR Monograph *Giant Clams in Asia and the Pacific* (Lucas 1988a; Lucas et al. 1991). The eighth species, *Tridacna tevoroa*, has only very recently been described. This rare species lives in a deep water (20–30+ metres) habitat in the eastern Fiji Islands and northern Tonga Islands. A possible ninth species has been described from the Indian Ocean (Srenko and Scarlato 1991). The authors are calling this clam *Tridacna rosewateri*. It is very similar to *Tridacna squamosa*, and its status as a new species may require further confirmation.

Figure 1.2 *Tridacna gigas*

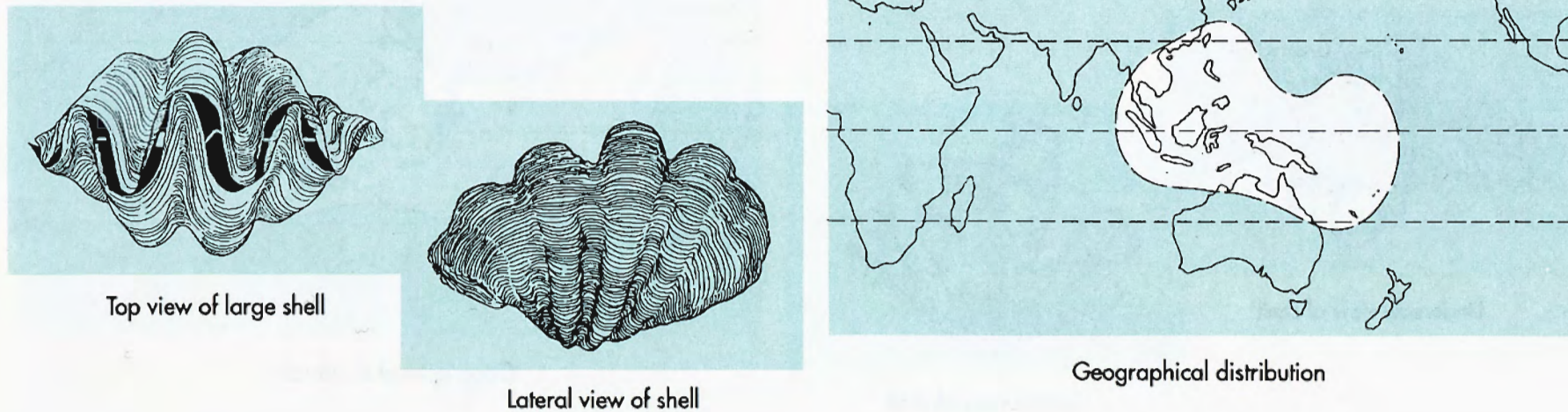


Figure 1.3 *Tridacna derasa*

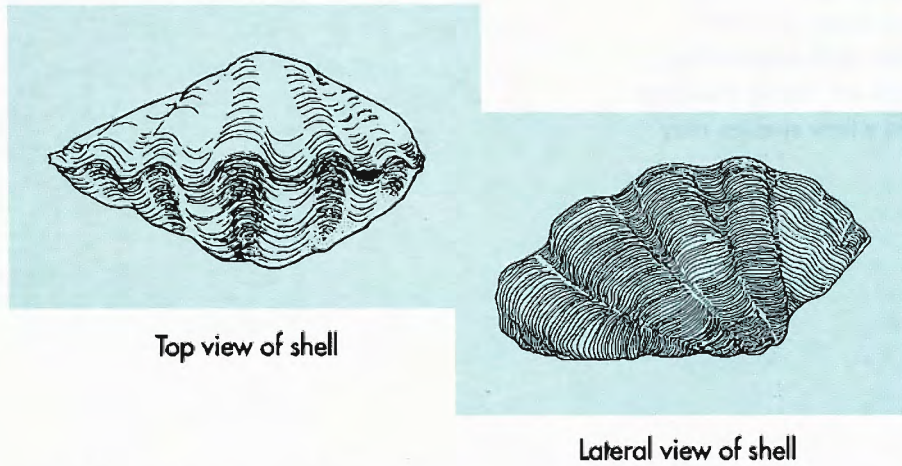


Figure 1.4 *Tridacna squamosa*

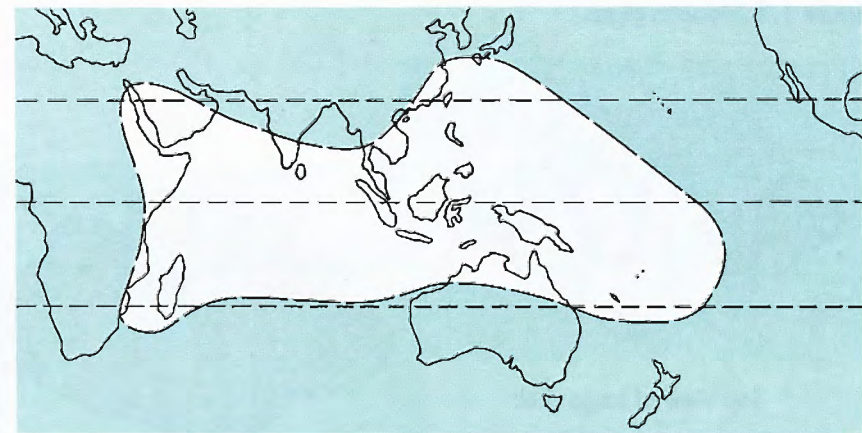
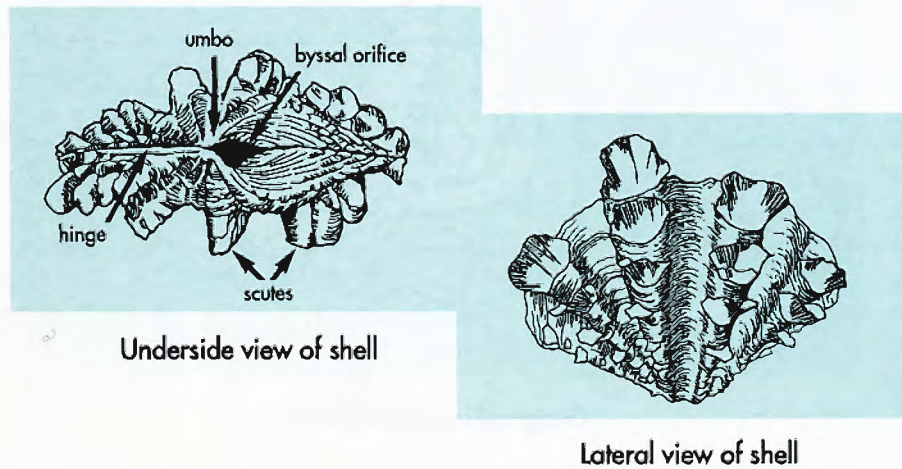
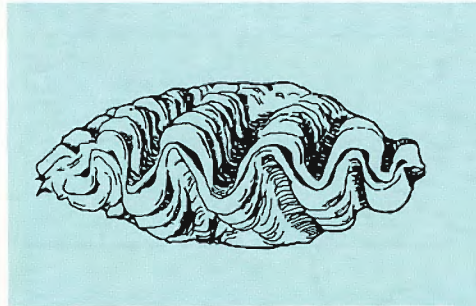
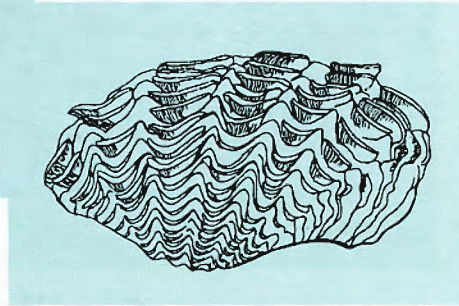


Figure 1.5 *Tridacna maxima*



Underside of shell

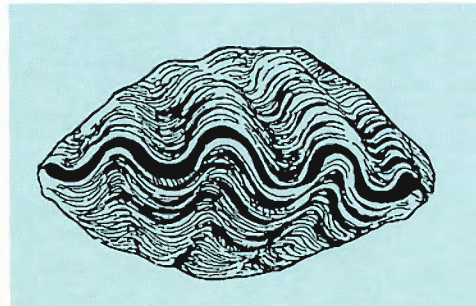


Lateral view of shell

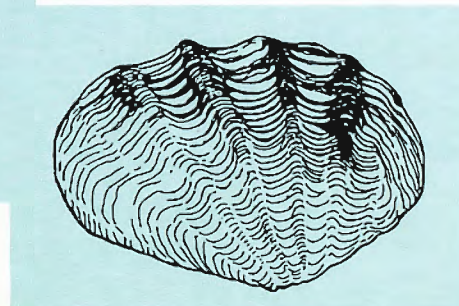


Geographical distribution

Figure 1.6 *Tridacna crocea*



Top view of shell

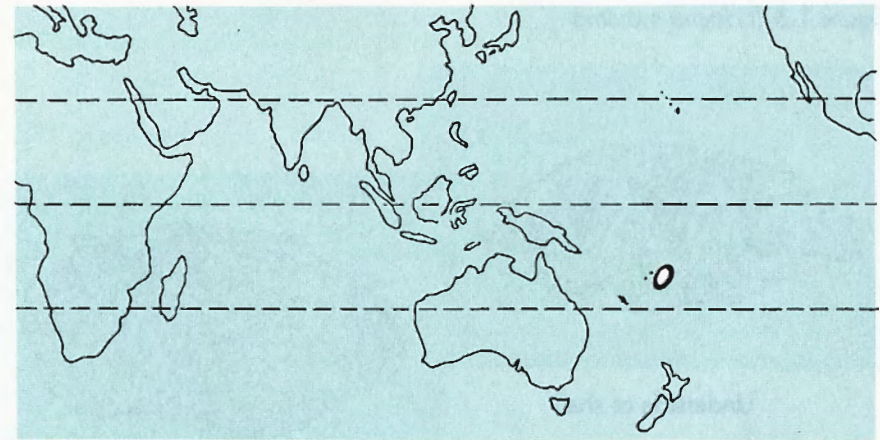
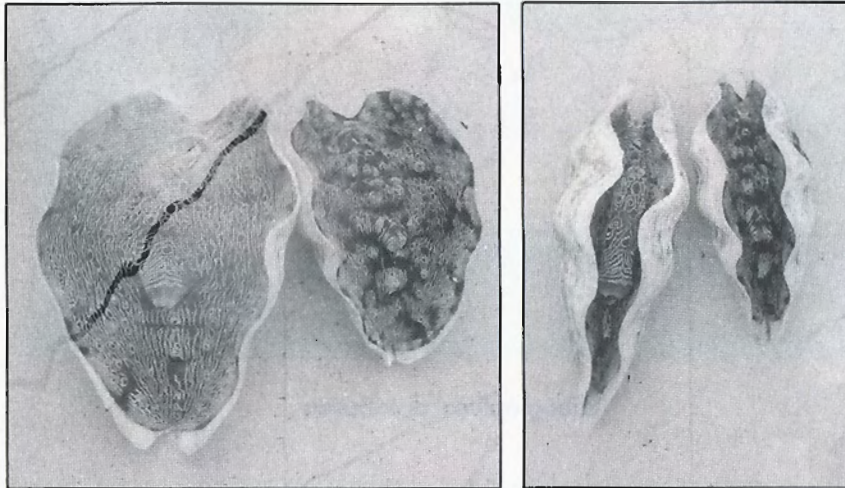


Lateral view of shell



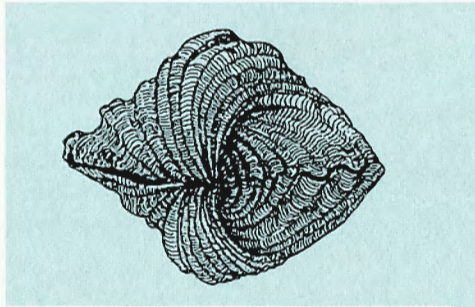
Geographical distribution

Figure 1.7 *Tridacna tevoroa*

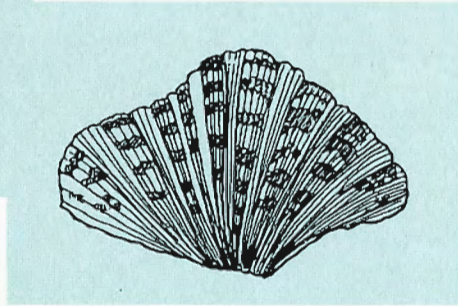


Geographical distribution

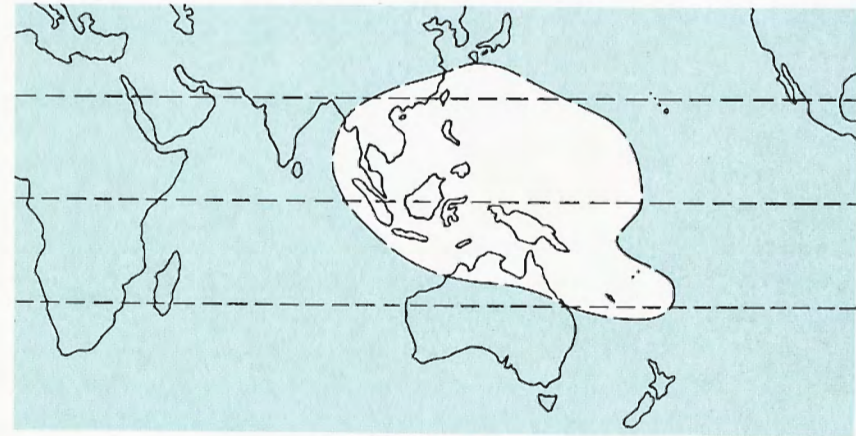
Figure 1.8 *Hippopus hippopus*



Underside of shell

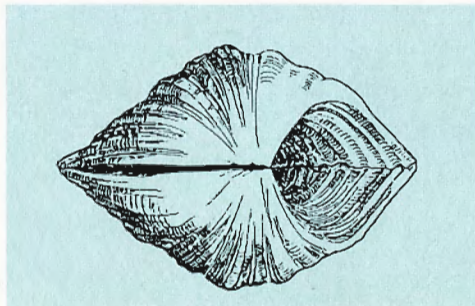


Lateral view of small shell

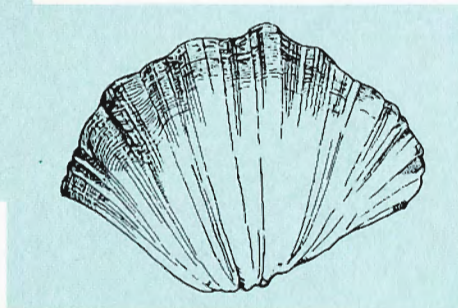


Geographical distribution

Figure 1.9 *Hippopus porcellanus*



Underside of shell



Lateral view of small shell



Geographical distribution

## Site selection: technical and ecological considerations

### 2.1 Hatchery and land nursery

The basic needs for a hatchery and nursery are:

- the seawater system;
- the aeration system;
- power; and
- culture vessels.

Each of these needs will have a bearing on the site selected.

#### 2.1.1 Site selection

A number of factors must be taken into consideration when choosing a site for a giant clam hatchery and land nursery (Heslinga et al. 1990). Huguenin and Colt (1989) suggest the following factors when considering choice of a hatchery site:

- Whether the site will be used primarily as a research facility or primarily as a commercial operation. The scale of operations, especially with regards to the seawater system, will be significantly different depending on the planned primary use. If the objective is research-oriented then the seawater system may be constructed from one or two approaches: build relatively cheaply for a limited period or to cover objectives; or build a more expensive system to start with, but one which will enable future expansion to cover new objectives or requirements. A planned commercial operation will tend toward the second approach in that it will be permanent and somewhat expensive initially, but it should also be built to specifically cover objectives.

## HATCHERY AND NURSERY CULTURE OF GIANT CLAMS

- Meteorological factors such as winds, light, air temperature and variations, relative humidity, and precipitation.
- Locational factors such as watershed characteristics, ground water supply, tides, waves, coastal currents, existing facilities, accessibility of site, and history of site use.
- Soil type, profile, subsoil characteristics, percolation rate, topography and distribution of soil types, particle size and shape, angle of repose – wet/dry, fertility, microbiology of soil, and leachable toxins.
- Biological factors such as primary productivity, local ecology, wild populations of broodstock, predators and their density, endemic diseases and parasites.
- Water quality. Sites near high density human population and industry should be avoided. Proximity to agricultural operations should likewise be avoided as the pollution from fertilizers, pesticides and herbicides is likely during the wet season. Table 2.1 shows the suggested allowable levels for marine applications. If the results of water quality tests are poor, small-scale rearing experiments may need to be carried out to see if wildstock or cultured juvenile giant clams survive or grow as would be expected under suitable conditions.

In the final analysis, political and economic factors may limit the choice of sites and water quality screening may be limited. If most of the factors and parameters screened for are acceptable, though not excellent, it may be worth while to develop the project. However, if some factors are very unfavourable, it may be wiser to halt plans to develop the project at the available site. In such cases it is likely that the facility is doomed to failure in the long term, if not the short term.

### 2.1.2 The seawater system

The seawater system is essential to the entire operation so the right choices must be made for pipe material and size, filtration, pump type, seawater settlement-storage tanks, and a backup system.

**Table 2.1** Water quality: suggested allowable levels for marine applications

|                    |                        |
|--------------------|------------------------|
| Ammonia            | < 10 µg/L <sup>a</sup> |
| Nitrite            | < 0.1 mg/L             |
| Dissolved oxygen   | > 6 mg/L               |
| Total gas pressure | < 20 mm Hg             |
| Carbon dioxide     | < 10 mg/L              |
| Hydrogen sulphide  | < 1 µg/L               |
| Chlorine, residual | < 1 µg/L               |
| pH                 | < 7.9–8.2              |
| Temperature        | (25–32° C)             |
| Salinity           | (32–36 ppt)            |
| Cadmium            | < 3 µg/L               |
| Chromium           | < 25 µg/L              |
| Copper             | < 3 µg/L               |
| Iron               | < 100 µg/L             |
| Manganese          | < 25 µg/L              |
| Mercury            | < 0.1 µg/L             |
| Nickel             | < 5 µg/L               |
| Lead               | < 4 µg/L               |
| Zinc               | < 25 µg/L              |

<sup>a</sup> Higher levels of ammonia would be acceptable for giant clams since ammonia is usually in short supply for the symbiotic partner of the clam, the zooxanthellae.

Source: Huguenin and Colt 1989.

### *Pipe material and size*

The cheapest, most flexible, and UV-resistant suction or intake pipe is black polypipe. These are readily available in 50 mm, 75 mm, 100 mm (2, 3, and 4 inch) diameters in 75 m rolls which can be joined with special polypipe connectors, or they may be heat-welded together. Commercially available PVC pipe is rigid and would tend to crack with wave action during storms. Heslinga et al. (1990) mention their use of a heavy-duty, stainless steel-reinforced vinyl hose for a suction line through the intertidal zone, but the cost may be prohibitive if a long suction line is required. The pipeline should be buried if this is feasible or cement mix in bags should be dropped at regular intervals (8–10 m apart) over the pipes to anchor them. It is wise to lay down two sets of intake pipes so that there are two systems available for alternating use and rest (anaerobic conditions during the rest kill fouling organisms inside the intake pipe).

A long intake line should be avoided if possible. The hatchery and tanks should be located as close to the shore as possible, provided there is no danger of storm damage. The longer the line the greater the frictional losses from the flow of seawater. Likewise, biofouling problems in seawater intake pipes increase the frictional losses as the inner pipe diameter becomes smaller and irregular in shape. A high water velocity can limit biofouling but it should be a minimum of 3 m/second (Huguenin and Colt 1989). The pipe size and pump size will determine the water velocity. It is advisable to use at least a 75 mm (3 inch) diameter pipe if the intake distance is greater than 100 m.

### *Filtration*

If filtered water is desired for the entire operation, either an offshore gravel-filled 'crib' with suction pipe inside or a well point could be built. The 'crib' is a gravel-filled box pit dug out of clean sand or gravel with the suction pipe end slotted (1.5–2.5 mm slots) and embedded in the packed gravel. The gravel-filled pit is then covered with a cement top and this in turn covered with clean sand or gravel up to about 30 cm.

The well point is a packed gravel-filled cylinder pit with the intake line making a 90° turn down into the substrate. Again, the vertical end section of the intake pipe has 1.5–2.5 mm slots cut all around it for



water intake. These seawater wells reduce the flow of seawater into the system but the water is filtered from the start.

Another method of filtration is to set up an inline 'pool' sand filter on the pressure side of the seawater pump. Generally, such a filter ensures that particles of 50–100  $\mu\text{m}$  are removed from the seawater ( $1 \mu\text{m} = 1 \times 10^{-6} \text{ m}$ ). Back-flushing of this filter may be required for 10–15 minutes daily to remove trapped debris.

If turbidity is low at a site or if there is little algal or other debris floating around which could be sucked into the intake pipe, a simple above-substrate marine intake of raw seawater may be adequate. Even in this case, it is advisable to put a screen of 12–25 mm (0.5–1 inch) over the end pipe to avoid sucking in large invertebrates or fish. The screen would have to be replaced or cleaned at regular intervals to avoid fouling and reduction of intake flow of seawater.

Waste seawater must be discharged where there is no chance of it being recycled into the intake system. The discharge could empty out just off the beach and the intake could be much further out, over the reef edge. Drains should be larger than normal pipes to handle rapid and simultaneous draining of several tanks at once.

### *Pump type*

If the hatchery site is on mains power supply it is sensible to have at least one electric pump. A 5.5 kW (7.4 hp) pump will fill a 100 000 L settling tank using a 90 mm diameter polypipe about 150 m long in 60 to 70 minutes. In 1991 this was the situation in the Tonga fisheries hatchery, and the settling tank had to be filled only once per day. Although this size pump is not necessary for current usage, the facility in Tonga has the potential for expansion.

Perhaps the most useful pump to have either as a backup or the main pump is a diesel pump. These pumps are being used at the Bolinao facility, University of the Philippines; Makogai Island, Fiji Fisheries (no mains power); Aitutaki Island, Cook Islands Marine Resources (no mains power, yet!); Tonga Fisheries; and Western Samoa Fisheries. Heslinga et al. (1990) used Yanmar diesel pumps

(3 inch model, 6 hp) at the Micronesian Mariculture Demonstration Centre (MMDC) for some years because of the unreliability of mains power. They now use stainless steel submersible pumps (sold by Fritz Aquaculture Company) and maintain the Yanmar diesels for standby duty. [See Heslinga et al. (1990) for a detailed account of diesel pumps to use in a giant clam hatchery.]

#### *Seawater settlement-storage and header tanks*

If continuous running of the main pump is not a satisfactory arrangement, then a settlement-storage and/or a header tank should be incorporated into the system. Heslinga et al. (1990) do not recommend the use of storage or header tanks because they claim that the water quality changes considerably even if it is in a storage tank for only a short time. However, most other clam hatchery and land nursery facilities in the Pacific region use tanks to store a percentage of the total hatchery or nursery tank volume. If both the main pump (as in the Tonga Fisheries example above) and the settlement-storage tank are large enough, there may be a considerable resting period for the pump before it must fill the tank again. In Tonga, the 100 000 L tank acts as a sedimentation tank to reduce turbidity of the unfiltered water being pumped in. Even a period as short as 30 minutes can significantly reduce turbidity in a settlement tank. If there is fine silt, however, it will not settle out even with a long residence time.

Header tanks are generally raised on a tower, thereby minimising further pumping by means of gravity flow to the hatchery or nursery tanks. A cement tower and header tank is filled directly from the seawater pump at the Silliman University Marine Laboratory in the Philippines. In Tonga, a small pump takes water from the 100 000 L settlement tank and pumps it on demand (from a float switch in the header tank) to fill the header tank.

### **2.1.3 The aeration system**

In giant clam culture, aeration is important for its mixing properties rather than for the provision of oxygen, except perhaps in the embryonic and early larval stages when both good mixing and oxygen are needed. For mixing, it is wiser to use a diffuser with larger, coarser bubbles rather than one with very fine bubbles, which could cause gas supersaturation (total gases, especially nitrogen) which is

lethal in the case of some larval fish. Although bivalve molluscs can handle lower levels of oxygen than most other aquaculture animals it is not wise to attempt supersaturation.

There are two main methods of aeration: gravity aerators and submerged aerators. The gravity aerators are cheaper and in most cases supply the oxygen needs for both hatchery and land nursery tanks, but they do not provide mixing. An automatic mixing paddle fitted to each tank is required in combination with a gravity aerator system. Submerged aerators are probably more cost effective. This method of aeration may use air compressors or air blowers. Few hatcheries now use air compressors because there is a danger of oil leaking through rings and seals and getting into the air. Also, high pressure air is not usually needed and can cause problems such as supersaturation. Rootes type air blowers are the air blower of choice (see Appendix). Heslinga et al. (1990) recommend Sweetwater blowers for their reliability, corrosion resistance and quietness. Air blowers give low pressure and high volumes of air; perfect for shallow nursery or hatchery tanks.

## 2.2 Ocean nursery and growout

Many of the factors influencing the choice of site for a hatchery and land nursery must also be considered in the determination of the ocean nursery and growout site. From the point of view of accessibility, security and cost efficiency, it is preferable to have the ocean nursery and growout site adjacent to the hatchery and land nursery. Depending on site suitability and/or availability this may not always be possible.

Sites may be intertidal or subtidal. The intertidal culture method pioneered in northern Queensland, Australia, is suitable for *Tridacna gigas* and *Hippopus hippopus* but has not been tested for the other species. An intertidal site is not suitable if it is close to rivers which threaten the site with a freshwater influx during the wet season. Although *Tridacna gigas* and *Hippopus hippopus* can handle salinity drops to 20-25 parts per thousand for short periods, regular repetition of these salinity fluctuations is very detrimental to their growth and survival. An advantage of an intertidal site with turbid seawater, over adjacent subtidal sites, is that light levels are at a maximum and an abundance of organic material is available for the clam to filter and feed upon. The advantage for the farmer is the

ease of accessibility to the site, especially during the spring low tides. The greatest disadvantage is the possibility of being hit by a tropical cyclone. This is discussed in detail in a companion volume on ocean nursery culture.

Subtidal culture is perhaps the most common culture method used in Pacific Island countries. It is suitable for all species of giant clams. The disadvantages are related to the depth of the site. Scuba diving and boats are required to work at the site; fouling of meshes is greater than at intertidal sites; and light levels and consequently growth may be low if the site tends to have fairly turbid water. The advantage is a more stable environment with regards to water quality, including salinity, during heavy rains. Although the natural habitat of giant clams is amongst live coral reef (with the exception of *Hippopus hippopus* which is also found on rubble of intertidal reef flats) they may be cultured in other environments, such as seagrass beds. Once the clams have reached a size where they are virtually free of predators they will grow in habitats where they would not be able to settle as larvae and survive. The ocean nursery site near Bolinao, University of the Philippines, is an example. Part 2 of this manual, *Ocean Culture*, and Heslinga et al. (1990) give more details of considerations in choosing a subtidal site.

---

## **Site selection: economic considerations**

### *3.1 Markets for giant clams*

Giant clam farming is not a well-established industry and only a few firms produce and culture giant clams commercially. The economics and profitability of the industry have not been examined. There has been little time for the accumulation of commercial data; markets and production techniques are still in the development stage; and firms entering the industry have considerable scope for learning. Success in the giant clam industry depends on entrepreneurship, especially in the establishment of markets. Capital invested in the industry at present should thus be regarded as venture capital. Nevertheless, effective production techniques have been established and profitable possibilities exist.

The main end-markets for giant clams are for their meat, for their shells, and for their use as aquarium specimens. A small market may also exist for biological specimens for scientific demonstration and experimentation purposes. Additional end-products may be found, for example extracts from the clam for health or medicinal purposes. Each of the end-markets may be further subdivided. For example, separate markets exist for meat or sashimi, for the muscle, for the mantle and for the whole meat of the clam minus the kidneys. Species differ in their ability to satisfy these different markets and this must be considered when deciding which species to breed and rear.

The purpose of establishing a hatchery may be to:

- sell the seed clams;
- provide seed for own growout operations; or
- provide seed for own growout operations and also to sell some seed commercially.

In all these cases, the demand for the seed is governed by the final demand for the products produced by growout of the seed. The demand for seed is derived demand and this has implications for the size of the market for seed and for the species of giant clam likely to be in greatest demand.

If the aim is to specialise in the sale of seed clams, it is important to consider whether these can be sold at a competitive price. If the seed is to be used in own growout operations, the alternative of purchasing seed should be examined.

The choice of location for the hatchery and nursery will depend on economic, institutional and ecological considerations. The most suitable available ecological site may not be the most economic site and vice versa. After eliminating all available sites that are unsuitable on ecological grounds (see Chapter 2) the remaining sites must be examined on economic grounds and the most profitable selected.

This chapter examines the economic and market factors which influence decisions about establishing and operating a commercial hatchery and nursery (see also Shang 1981 and Meade 1989).

### *3.2 Establishment costs*

Many factors must be taken into account when assessing the economics of a site. Account should be taken not only of current needs but also longer-term requirements for space if it is decided to expand future production.

- Availability and costs of inputs. For example, is the type of labour needed available in the area and what are the comparative seawater pumping costs at the site compared with alternative sites?
- Costs of getting the product to market or to growout from a hatchery-nursery. For example, if seed is to be sold commercially, long and uncertain journeys of seed will be expensive in terms of transport costs and mortality of seed in transit. Hence, a remote site which is ecologically

very suitable for a clam hatchery-nursery may be rejected on economic grounds if the main purpose of the enterprise is to sell the seed of clams commercially.

- Purchase or rental costs of land-site.
- Costs of preparing land site. The site may have to be cleared of vegetation, levelled and otherwise prepared for the installation of facilities.

Using the type of production system developed at the James Cook University Orpheus Island Research Station (JCUOIRS), the main capital outlays are likely to be for the hatchery building, the seawater supply system, worker amenities or accommodation, the tractor, utility truck and boats (Tisdell et al. 1990:16). Capital costs per unit of seed produced appear to fall quite rapidly with expansion in volume of seed production. Outlay on the seawater supply system, hatchery building, site preparation (where needed) and on transport equipment rises by a lot less than increased volume of seed production.

Using Australian prices prevailing in 1990, Tisdell et al. (1990) estimated capital outlays for different annual volumes of seed production (Table 3.1). For each annual volume of seed production, a range of capital costs is indicated. These allow for possible variations in outlays on hatchery buildings, worker accommodation and amenities, the seawater supply system and boats. Whether the higher or lower outlay figure applies will depend upon the situation faced by a particular nursery, for example, whether it is necessary to provide accommodation for workers, or on the size of seawater-pumping systems installed. Whether one takes the estimated upper or lower limit of capital costs, it seems that substantial economies in use of capital can be achieved by increasing the volume of production of seed in a hatchery-nursery operation.

**Table 3.1** Estimated capital costs of a hatchery-nursery operation<sup>a</sup>

| Annual number of seed | Total capital cost (A\$) | Capital cost per seed clam (A\$) |
|-----------------------|--------------------------|----------------------------------|
| 100 000               | 194 425 – 424 425        | 1.94–4.24                        |
| 500 000               | 271 240 – 516 240        | 0.54–1.03                        |
| 1 000 000             | 356 800 – 606 800        | 0.36–0.61                        |

<sup>a</sup> Based on the production system developed at the James Cook University Orpheus Island Research Station.

Source: based on Tisdell et al. 1990: 16

### 3.3 Operating costs

Wages and salaries are the major operating costs associated with hatchery-nursery operations. Other costs of significance are interest charges on funds employed, depreciation of capital items, fuel, and repairs and maintenance (Tisdell et al. 1990: 17). Even if interest is not actually paid on funds used by

the enterprise, an allowance should be made for it because the opportunity to invest funds elsewhere (for example in government bonds) and obtain a positive return has been foregone. This represents the opportunity cost of using funds in the enterprise. It is a real cost and should be taken into account (Shang 1981).

Significant economies of scale exist in relation to operating expenses (that is, running expenses excluding depreciation and interest charges), even though these economies are not as large as those for capital items. Economies occur in relation to labour, fuel use and repairs and maintenance. Estimated operating costs for a hatchery-nursery operation are as set out in Table 3.2, which also shows estimated full costs (costs inclusive of depreciation and an interest allowance). Calculations are made for two interest rates: 5% real rate; and 10% real rate.

### 3.4 Profit

The profit obtained by a firm in a year is equal to its total revenue for the year less its total costs for the year. Its total revenue is equal to its total volume of sales multiplied by the prices at which its products are sold.

The information in Table 3.2 can be used to estimate the profits which a hatchery-nursery enterprise could earn. It also indicates the minimum prices per clam required for a seed farm to break-even, after allowing for interest paid or forgone. Thus if minimum full cost estimates and an interest rate of 5% apply, a firm producing 100 000 giant clam seed per year would need to be paid A\$1.33 per clam to break-even, ignoring any packaging and freight costs or assuming that these are paid by the purchasers. As can be seen, break-even values are sensitive to the volume of production sales.

On the basis of information in Table 3.2, if giant clam seed were to sell for A\$1.00 each, a company producing 100 000 clams per year would make a loss. However, because of economies of scale, if it were to produce 500 000 clam seed per year and sell them at this price it would make a substantial profit. Allowing for a 5% rate of interest, it would make an average profit per clam of 52 to 63 cents or A\$260 000 to A\$315 000 in total profit per year. Allowing for 10% rate of interest, the company is able

**Table 3.2** Estimated annual operating and full costs of a hatchery-nursery operation<sup>a</sup>

|   | Annual number of seed |           |           |
|---|-----------------------|-----------|-----------|
|   | 100 000               | 500 000   | 1 000 000 |
| Operating costs                         |                       |           |           |
| Total (\$'000)                          | 101-122               | 144-173   | 183-226   |
| Costs per clam (A\$)                    | 1.01-1.22             | 0.29-0.35 | 0.18-0.22 |
| Full costs at 5% real rate of interest  |                       |           |           |
| Total (\$'000)                          | 133-177               | 186-242   | 238-310   |
| Costs per clam (A\$)                    | 1.33-1.77             | 0.37-0.48 | 0.24-0.31 |
| Full costs at 10% real rate of interest |                       |           |           |
| Total (A\$'000)                         | 143-201               | 204-272   | 261-345   |
| Costs per clam (A\$)                    | 1.43-2.01             | 0.41-0.54 | 0.26-0.35 |

<sup>a</sup>Based on the production system developed at the James Cook University Orpheus Island Research Station.

Source: based on Tisdell et al. 1990: 17



to earn a profit per clam seed of 46 to 59 cents or a total annual profit of A\$230 000 to A\$295 000. Annual estimated profit and losses for alternative volumes of production for production of seed are indicated in Table 3.3.

### 3.5 Discussion

Table 3.3 indicates that the production of clam seed has the potential to be a profitable enterprise, but that profitability using techniques similar to those used at the James Cook University Orpheus Island Research Station depends heavily on the scale of production. A hatchery-nursery producing only 100 000 clam seed per year is unlikely to be profitable given the techniques assumed in this analysis,

| <b>Table 3.3</b> Estimated annual profit from a hatchery-nursery operation <sup>ab</sup> (A\$) |                       |                 |                 |
|--|-----------------------|-----------------|-----------------|
|  | Annual number of seed |                 |                 |
|  | 100 000               | 500 000         | 1 000 000       |
| At 5% real rate of interest  |                       |                 |                 |
| Profit (loss) per clam seed  | (-0.33)-(-0.77)       | 0.52-0.63       | 0.69-0.76       |
| Total annual profit  | (-33 000)-(-77 000)   | 260 000-315 000 | 690 000-760 000 |
| Allowing for a 10% rate of interest  |                       |                 |                 |
| Profit (loss) per clam seed  | (-0.43)-(-1.01)       | 0.46-0.59       | 0.65-0.74       |
| Total annual profit (loss)   | (-43 000)-(-101 000)  | 230 000-295 000 | 650 000-740 000 |

<sup>a</sup> Based on the production system developed at the James Cook University Orpheus Island Research Station.

<sup>b</sup> Assuming seed sell at A\$1.00 each.

Source: Based on Tisdell et al. 1990: 17.

## HATCHERY AND NURSERY CULTURE OF GIANT CLAMS

---

unless the net price received by the nursery is well in excess of A\$1 per seed clam. Whether or not operations would be profitable at such low levels of annual production using alternative techniques has not been examined. However, economies of scale do appear to be important for hatchery-nursery operations. Smaller nurseries are likely to find it difficult to compete with larger ones unless they have some locational or other advantage. It is more likely that clam seed will be supplied by a few large hatcheries-nurseries rather than by many small operations. Concentration may also allow for better public control over the taking of giant clam broodstock from the wild, and for the enforcement of quarantine and related precautions where these are needed, for example in relation to exports.

This chapter has developed a framework for analysing the profitability of a giant clam hatchery-nursery operation. It is the first such framework to be developed. Adjustments to actual prices and costs can be made within this framework to take account of variations in local economic and other conditions.

## Broodstock collection and holding

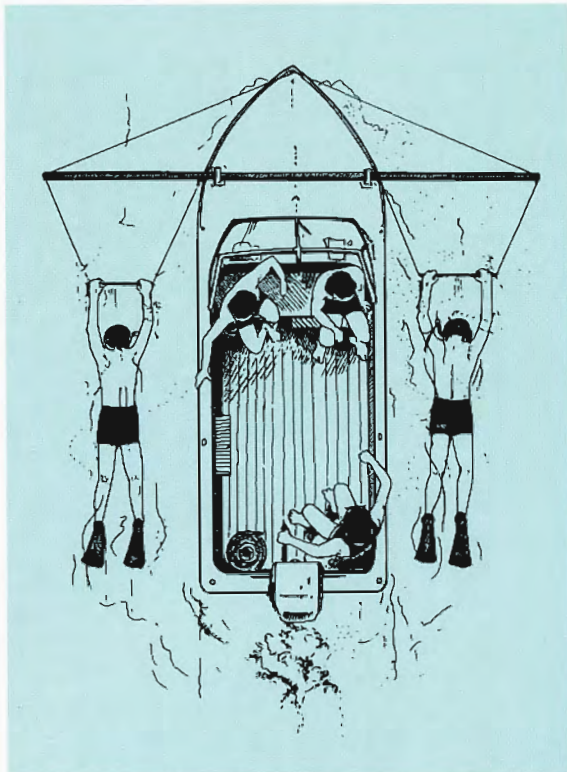


Figure 4.1. Method of towing to assess clam stocks (source: modified from Munro 1986)

The choice of good broodstock is important for the livelihood of a clam hatchery and farm. Testing the reproductive condition of the clams (biopsy sampling) may be necessary.

### 4.1 Collecting broodstock from the field

In some situations it may be possible to acquire stocks of tridacnids from areas near the hatchery. In the case of Australia's central-northern Great Barrier Reef the populations of tridacnids are quite high on some reefs but collection of broodstock is restricted by law and may only be done, with permission, on the more general-use zoned areas of the reef. If stock is to be collected from reefs, then it is necessary to have a vessel which has plenty of deck space and running seawater from a deck hose.

#### 4.1.1 Towing procedure (for a stock survey or for collection of stock)

An effective method of surface towing was adopted by Munro (1986) in his survey of giant clam stocks in Kiribati. This method was used in the FAO-funded giant clam stock surveys in Tuvalu and Tokelau (Braley 1988a, 1989), and Niue (Dalzell et al. 1990). Two divers with snorkel gear (mask, snorkel and fins) are towed along the sides of a small boat from a 5 m length of galvanised 3.8 cm (1.5 inch) pipe (Munro used wood) secured across the boat just behind the foredeck (Figure 4.1). Short lengths of rope are required to secure the pole to the boat and to provide loops which can be held by the divers being towed. The keel of the boat provides a natural border so that the two divers do not count some clams twice.

The width of the tow track scanned by the divers will vary due to the clarity of the water and density of clams. In clear water where clam densities are low, a combined width of 10–14 m could be expected,

but in a situation where the densities are high the combined width may be only 4 m. There are two useful ways to determine the distance of each tow.

- The speed of the boat can be determined by timing a floating object from the stern of a boat to the end of a 10 m line towed behind the boat; the time of the tow can then be used to determine the approximate length of the tow. When using this method the driver of the boat must have a steady hand to keep the speed constant.
- An optical distance-finder (Rangefinder 1200 m) may be used to measure the approximate distance to a float anchored at the beginning of the tow. If the two lenses on the rangefinder are out of focus, two images are seen and these must be lined up to estimate the distance. Accuracy is best when the length of the tow is between 150 and 400 m.

Recent giant clam surveys by the Fisheries Division in Tarawa, Kiribati, used the Munro (1986) method to assess clam stocks, and they also devised a method to mark the position of the tow accurately. The position of the float, which was anchored to mark the beginning of the tow, was determined by using a hand-held compass. The compass readings were later converted to true bearing readings and plotted on navigational charts.

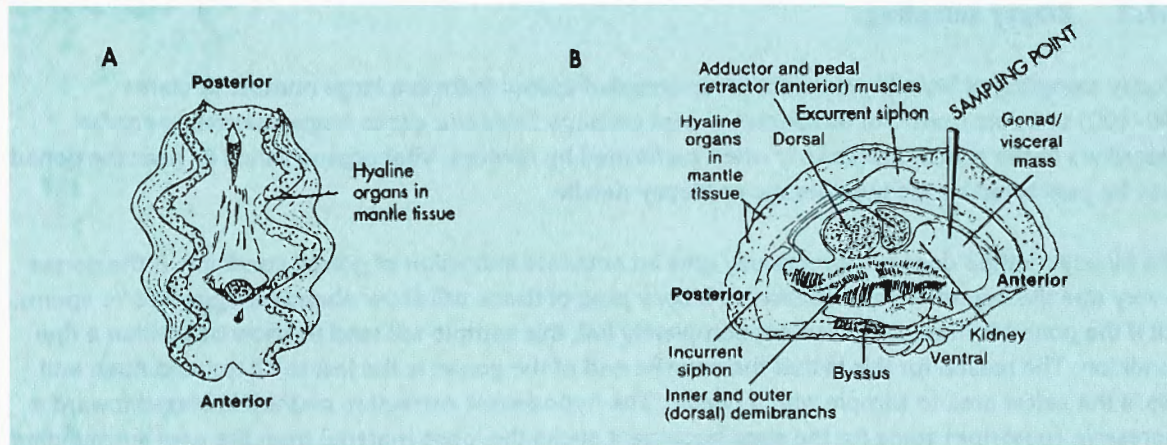
The University of the Philippines Marine Science Center (UPMSC) employed belt transects for resource surveys. The transects were made by two divers using scuba gear. The first diver swims the distance of 100 m unreeling a 100 m calibrated fibreglass tape, while a second diver follows, measuring and counting clams within a 2.5 m wide path to the right of the transect line. At the end of the line, the first diver swims back, recording all clams within a 2.5 m wide area to his right of the line, while the second diver reels in the transect line as he swims back. Information such as depth, substrate type and percentage of dead and live coral within the immediate vicinity of the clam can also be recorded. With this method, two divers can cover 1000 square metres in 30 minutes to an hour, depending on clam abundance.

#### 4.1.2 Biopsy sampling

Biopsy sampling of broodstock is not recommended unless there is a large number of clams (50–100) to select from. For all species except perhaps *Tridacna gigas* biopsy sampling can be hazardous to the clams, particularly when performed by novices. Vital organs which lie near the gonad may be punctured by the hypodermic or biopsy needle.

The biopsy method does not necessarily give an accurate indication of gonad condition. If the gonad is very ripe the hypodermic extraction or biopsy plug of tissue will show abundant eggs and/or sperm, but if the gonad is mostly ripe but not completely full, this sample will tend to show other than a ripe condition. The reason for this is that the anterior end of the gonad is the last to fill out and ripen and this is the safest area to sample with a needle. The hypodermic extraction method is biased toward a regressive (post-ripe) stage for the eggs because it sucks the loose material from the area surrounding the needle. However, despite the drawbacks of using a biopsy method it may be useful to know which clams are very ripe in order to avoid carrying large numbers of clams from the field to the spawning tank on the chance that they may be ripe. For those who wish to utilise the biopsy technique it is described here in detail.

Samples are taken either by a biopsy needle which removes a piece of tissue in a narrow diameter metal bore, or with a hypodermic syringe. The biopsy needle may be more traumatic for the clam. The hypodermic syringe method (Braley 1984, 1986, 1988b) is easy but the sample must be taken from the correct area of the clam to avoid puncturing the kidney or other vital organs. For a large clam such as *Tridacna gigas*, a 10 cm hypodermic needle and a 20 mL plastic plunger syringe generally allows small quantities of gonad tissue to be obtained (Figure 4.2). Much smaller needles should be used with smaller species of tridacnids. It should be noted that *Tridacna derasa* and the *Hippopus* species appear to be very sensitive to any biopsy and some of them may die. Approaching the gonad from the anterior end of the clam is safer for *Hippopus hippopus* (Shelley and Reid 1988) (Figure 4.3). Where broodstock are limited it is not wise to biopsy the clams due to the possibility of mortalities. A very rough visual assessment of gonad maturity can be made from the colour of the visceral mass. In many cases (though not always), a deep orange colour of the tissue covering the visceral mass and seen through the excurrent siphon opening indicates a ripe gonad.

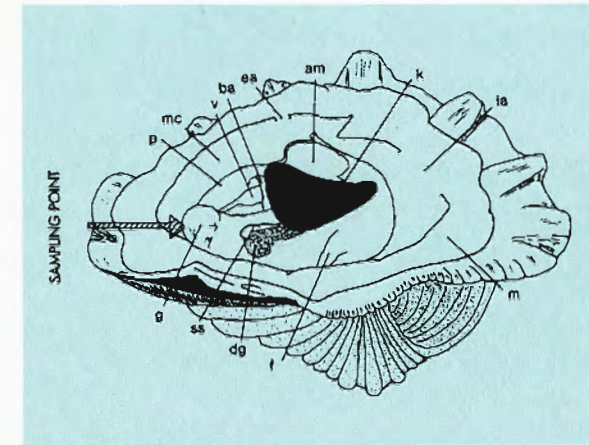


**Figure 4.2** Position for hypodermic syringe sampling of clam gonad: *Tridacna gigas* (source: after Braley 1984): A. dorsal view; B. view from right side

Pressure should be held on the syringe plunger as the needle is slowly pulled from the gonad; gonad material will be slowly sucked up into the syringe. The sample should be preserved in 2% buffered formalin in small numbered vials and the samples examined microscopically as soon as possible (aboard ship if during a collecting expedition). The syringe and needle should be rinsed out with seawater after use and then sterilised with methylated spirits before being used again on another clam. The following general description will help determine the quality of eggs in samples.

*Developing.* Eggs which are generally tear or pear-shaped (the small end having still been attached to the follicle wall) and not the full size for the species. In *Tridacna gigas* the ripe size is about 100  $\mu\text{m}$ , in *Hippopus hippopus* and *Hippopus porcellanus* the size is about 115  $\mu\text{m}$ , and in other species ripe size is usually 100  $\mu\text{m}$  or less (Figure 4.4).

*Ripe.* Eggs are average size for that species; are usually rounded or polygonal in shape from being compressed by other eggs in the follicle, vitellogenesis complete (ova cytoplasm filled with yolk); easily ruptured (Figures 4.4 and 4.5).



**Figure 4.3** Position for hypodermic syringe sampling of clam gonad: *Hippopus hippopus* (source: after Shelley and Reid 1988). Key: am, adductor muscle; ba, 'bulbus arteriosus' or 'aortic bulb'; ea, exhalent siphon; f, foot; dg, digestive gland; g, gonad; ia, inhalent siphon; k, kidney; m, mantle tissue; p, pericardium; ss, style sac; v, ventricle (of heart).



Figure 4.4 Stages of development of *Tridacna gigas* eggs from hypodermic extract samples: developing to ripe (source: after Braley 1986, 1988b)

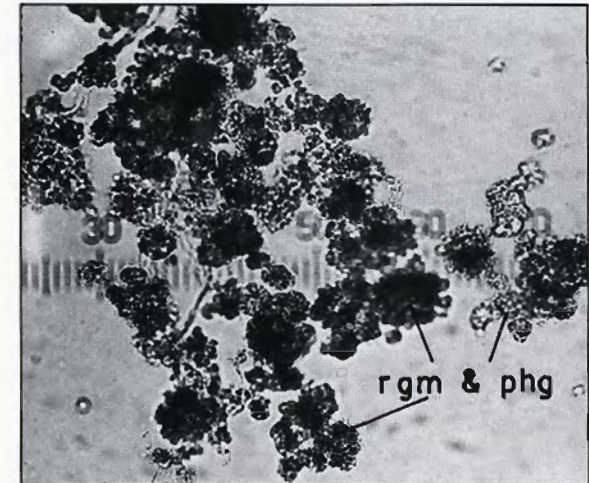
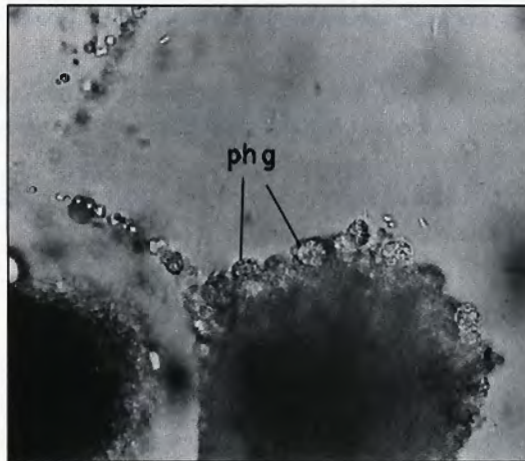
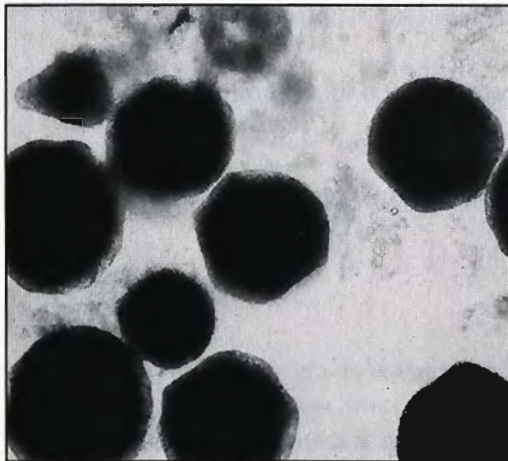
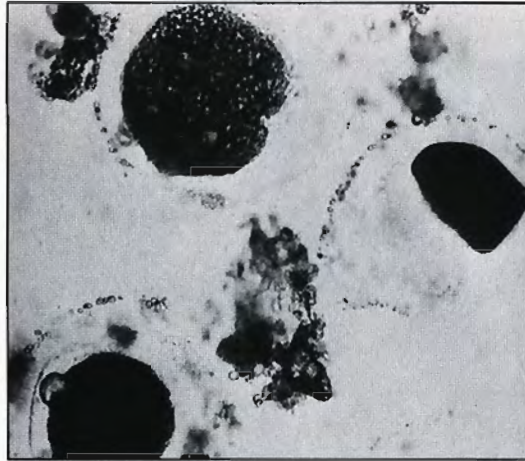
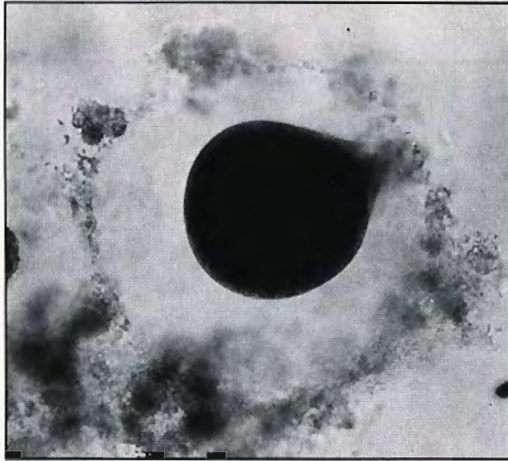
*Regressive (post-spawning).* Eggs of any size but degenerative (yolk partially broken out of ovum; amoebocyte cells surrounding ova, resorbing gametes) (Figure 4.6).

*Resting.* Lack of eggs in sample (at least two extraction attempts with a hypodermic need to be made to be certain of lack of eggs) (Figure 4.7).

#### 4.1.3 Collection and care in transport

A length of 12–16 mm diameter rope with loops spliced at both ends is placed around large clam specimens (*Tridacna gigas* or *Tridacna derasa* greater than 50 cm) with one end passing through the loop of the other end so that the clam is held snugly. The free loop is attached to a winch or another rope and pulled aboard the boat (Figure 4.8).

If smaller species of clams are being collected it will be necessary to use a knife to carefully cut away the byssal attachment to the substrate; this may also entail breaking away some of the coral with a chisel to reach the byssal attachment. The species which have byssal attachment are *Tridacna squamosa*, *Tridacna maxima* and *Tridacna crocea*.

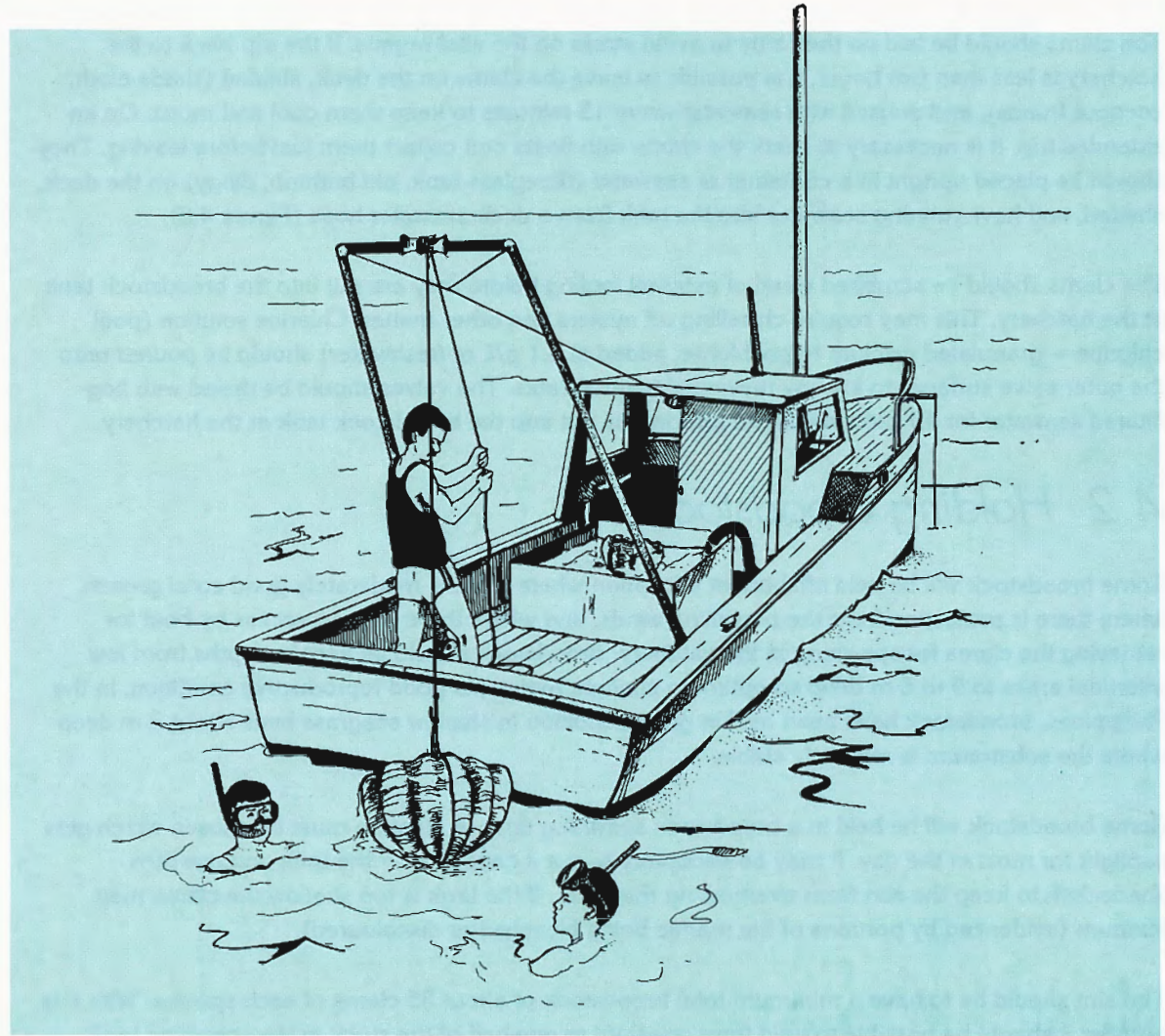


**Figure 4.5** Ripe ova in hypodermic extract samples (source: after Braley 1986, 1988b)

**Figure 4.6** Regressive ova in hypodermic extract samples, showing phagocytic amoebocytes (phg) on surface of regressive ova (upper - 100x mag, lower - 200x) (source: after Braley 1986, 1988b)

**Figure 4.7** Resting ova in hypodermic extract samples, showing both residual gonadal material (rgm) and phagocytic amoebocytes (phg) present in small amounts (100x; 1 scale unit - 10  $\mu$ m) (source: after Braley 1986, 1988b)





The clams should be laid on their side to avoid stress on the vital organs. If the trip back to the hatchery is less than two hours, it is possible to leave the clams on the deck, shaded (shade cloth, coconut fronds), and doused with seawater every 15 minutes to keep them cool and moist. On an extended trip, it is necessary to mark the clams with floats and collect them just before leaving. They should be placed upright in a container of seawater (fibreglass tank, old bathtub, dingy) on the deck, shaded, and have running seawater into the tank from a deck seawater hose (Figure 4.8).

The clams should be scrubbed clean of external fouling before they are put into the broodstock tank at the hatchery. This may require chiselling off oysters and other matter. Chlorine solution (pool chlorine – granulated calcium hypochlorite; added at 0.1 g/L of freshwater) should be poured onto the outer valve surfaces to kill any unwanted invertebrates. The valves should be rinsed with bag-filtered seawater for 45 seconds before the clam is put into the broodstock tank at the hatchery.

### *4.2 Holding broodstock*

Some broodstock will be held offshore at a location where there is moderately good coral growth, where there is protection from the prevailing winds, and where there is good access by boat for retrieving the clams for spawning in the hatchery. Broodstock should be kept in depths from low intertidal areas to 5 to 6 m deep so optimum sunlight maintains good reproductive condition. In the Philippines, broodstock have been held in good condition in shallow seagrass beds about 2 m deep where the substratum is relatively stable.

Some broodstock will be held in a broodstock spawning tank. A location must be chosen which gets sunlight for most of the day. It may be necessary to put a canopy over the tank and use 50% shade cloth to keep the sun from overheating the water. If the tank is too shallow the clams may sunburn (evidenced by portions of the mantle being bleached or discoloured).

The aim should be to have a minimum total broodstock of about 35 clams of each species. With this number it should be possible to hold from one-third to one-half of the stock in the spawning tank. Tagging of broodstock is recommended. Stamped metal tags last longest but plastic Dymo tags may

also be used. Two-part epoxy glues, particularly those which can be administered underwater or on slightly wet surfaces are best for attaching the tag to a clean scrubbed section of shell. Epigen 503 and Aquatapoxy are two brands which have both been used with success. Tagged broodstock facilitates good record keeping of natural and induced spawnings, and this will build up knowledge of clam reproduction.

#### 4.2.1 Tank type and size

The tank shape may either be raceway or circular. Both shapes have been successful, but a circular tank with a central drain and good water circulation allows a more even distribution of fresh seawater to each clam than does a raceway which has the inflow and outflow at opposite ends.

Fibreglass tanks are good because they are lightweight and easily moved to different locations if desired, but they are expensive. In the Philippines, wooden raceways using marine plywood are surface-coated with fibreglass. Such raceways are not as expensive as true fibreglass tanks, and with proper maintenance may last for five years. Cement block tanks are very permanent and are not cheap. Heslinga et al. (1990) recommend cement block tanks and give a very detailed account of their construction.

Above-ground pools using commercial or custom made metal walls and plastic liners are a cheap alternative for large volume tanks (3000–10 000 L). Commercial splasher pools (for example, Clark Rubber pools) can last for two to three years, but care must be taken with the metal walls which collapse easily when outside pressure is exerted. If a splasher pool is used to hold broodstock it is recommended that a custom-made corrugated roofing iron wall be constructed and a plastic liner of 0.7–1 mm thickness be obtained. A tank with 45 cm high walls would be ideal for the smaller species of tridacnids but a 70 cm high wall is required for the larger *Tridacna gigas* and large specimens of *Tridacna derasa*.

It may be necessary to raise the broodstock tank above flat ground to help drainage of waste seawater. A circular corrugated metal ring 40 cm high and 1 m wider than the tank, can be used. The ring being filled with coarse sand and/or rubble with the top 10 cm filled with fine sand which has had sharp coral pieces removed.

When preparing splasher pools the sand will have to be sculpted to drain in the centre or near an edge of the pool. This base will be covered with a plastic liner for the splasher pool. The easiest way to put the drain in the liner is to lay the liner out to fit the floor and tank walls, cut the liner carefully in a cross just over the pipe drain (which has been buried beneath the raised sand floor). A female PVC fitting (50 mm or larger recommended) is flush with the lowest point of the sand floor and connected to the buried drain pipe. This female fitting will have been cemented in place to give it weight and not allow movement. The cross cut in the plastic liner should now be cut to the shape of the female fitting and epoxy glue or silicon-rubber sealant put on the adjacent cement and underside of the plastic liner. When this is set, a male fitting with a standpipe put in its female end can be screwed into the female fitting drain pipe (Figure 4.9).

If there is suitable fall in the natural landscape it will not be necessary to build up the pool for drainage. Removal of nut grass and other hardy grasses which can grow up through a thin layer of sand and through the pool liner bottom is essential. To do this the soil needs to be dug for at least a metre wider than the diameter of the pool and the worst of the grass roots removed. It is then advisable to soak the soil with seawater to kill the vegetation. Alternatively, a herbicide can be used. Sand should be spread over the area before the liner is put down. In-ground raceways have been built in the Philippines using custom-made canvas lining. The ground is excavated to about 0.5 m and the base lined with fine sand. The canvas is then fitted into the excavation, using plywood material and cocolumber (coconut tree timber treated for termites) for support along the sides. Sturdier fibreglass, moulded plastic, ferrocement or cement block tanks will not require these steps other than placement of the tank at a level for the best drainage.

### **4.3.2 Seawater flow**

The flow rate will depend on the number of clams in the tank but it is recommended for a large tank (10 000 L) that turnovers are in the range of 1.2–2 per day. This is equivalent to a flow of 8.3 to 13.8 L/minute into the tank. Higher flows are better. One facility pumps water at a rate of 20 to 25 L/minute during the day in all 12 to 16 tonne tanks and turns the water flow off at night.

During spawning it may be desirable to replace water in the broodstock tank quickly so it is wise to consider putting two drains in the broodstock tank (if it is large) and at least two seawater taps available for refilling. A 50 mm or larger drain pipe is ideal.

It is recommended that water added to broodstock tanks is filtered with 25  $\mu\text{m}$  GAF filter bags. This is especially so after the clams have been collected and the outer shell valves cleaned with chlorine. This prevents unwanted invertebrates being introduced to the broodstock tank and lessens the possibility of contamination when spawning occurs and eggs and sperm are collected.

### 4.3 Broodstock conditioning

It is a well-known practice to condition oysters, mussels and other commercially produced bivalves in the pre-spawning period. This is done by combining slightly elevated temperatures with algal feeding, which allows the animals to speed up the normal gametogenesis (gamete production). Since the products of the symbiosis with zooxanthellae in giant clams accounts for a high proportion of the clam's metabolic requirements, the conditioning of broodstock requires consideration for the zooxanthellae symbiont. Addition of algal medium nutrients may therefore be an important step in giant clam broodstock conditioning. This is a very new area and the results so far need to be treated with caution. Mass algal culture nutrients have been tried (for example, Dix Mix, see section 7.1.2) at one-tenth dilution of that used for mass algal cultures on a daily and alternate day basis. Proper experimental trials using a common algal stock culture medium such as F2, and deleting components of the medium to study effects on growth of the clams is required.

#### 4.3.1 Winter holding

For higher latitude areas within the tropics, the drop in seawater temperatures during the winter months can greatly slow the metabolism of juvenile and adult clams. This will most likely have an effect on gametogenesis. There are two ways to condition broodstock for an earlier spawning in spring.

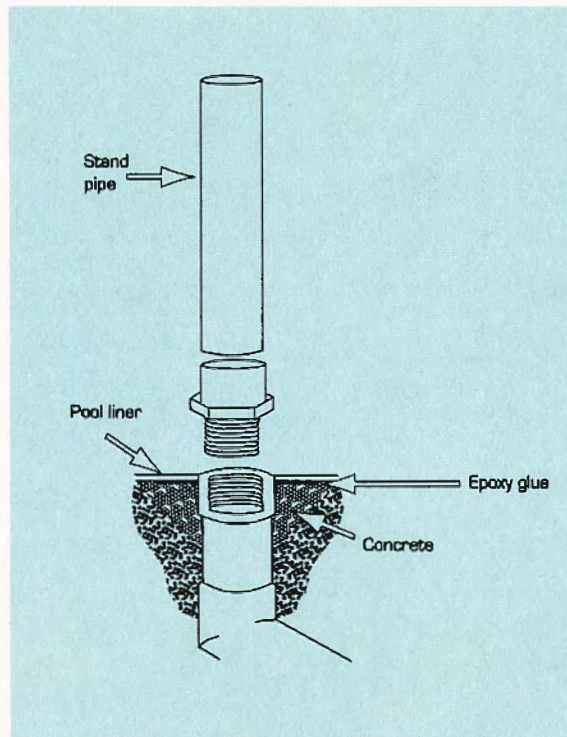


Figure 4.9 Putting a drain in a large splasher pool liner

### *Heating water*

The flow-through water may be heated in the broodstock tank by means of a heat-exchange system attached to a generator, by an on-line gas heater or by large electric heaters placed directly into the tank. A cheaper alternative method of heating the water would be to build a framework canopy structure over the tank(s) and cover this with translucent reinforced plastic greenhouse material. A coral rubble trickle filter with an algal scrubber combination and a pump can be used to recirculate seawater, especially at night when air temperature falls rapidly. The tank may be on a slow flow-through during the day when air temperatures inside the greenhouse reach the 35–40°C. At night the recirculating system might be used to more efficiently retain the water temperature attained during the day. Alternatively, the flow-through during the day could be run through the biofilters and the recirculation pump switched on at night. A recirculating system has been used at James Cook University Orpheus Island Research Station on juvenile *Tridacna glgas* with success during the winters of 1989 and 1990.

### *Nutrient addition*

Improved growth rates have been shown in nutrient-treated juvenile giant clams over controls (Heslinga 1988; Solis et al. 1988; Braley et al. 1992). This nutrient enrichment has recently been tried on *Tridacna glgas* broodstock at James Cook University Orpheus Island Research Station. General observations indicate a great improvement in mantle coloration and general health of broodstock. It is not possible yet to state that the addition of nutrients enhanced gametogenesis or resulted in more nutrient-packed eggs. However, it is certainly worth considering some addition of nutrients to the broodstock tank throughout the winter months. This combined with temperature elevation may result in year-round spawning potential as is found near the equator. Nutrient addition may also be beneficial in summer.

Nutrients which may be added are sulphate of ammonia and superphosphate. The Dix Mix formula (section 7.1.2) can be used, but at one-tenth of the amount added for algal culture. Nitrates will also be taken up by clams but ammonia appears to be taken up more readily. Caution must be exercised with these nutrients because they are poisonous at high concentrations.

---

## Spawning

The term spawning refers to the release of eggs. The release of sperm should be referred to as such. This section of the manual deals with induced and spontaneous spawning in tanks, the collection and fertilization of eggs and egg count estimates. For information on all aspects of giant clam spawning see Stephenson 1934; Wada 1954; La Barbera 1975; Jameson 1976; Beckvar 1981; Gwyther and Munro 1981; Heslinga et al. 1984; Braley 1984, 1985, 1986, 1988b; and Alcazar et al. 1987).

### 5.1 Induced spawning

Spawning is induced when an outside stimulus which is not normally present (at least with such intensity) affects the clam with a resultant release of eggs. A number of methods of induction have been tried on giant clams, three successful ones are discussed below.

#### 5.1.1 Gonad extract

Early attempts at inducing spawning in giant clams (Wada 1954; La Barbera 1975; Jameson 1976) utilised gonadal material, obtained from sacrificing a ripe clam, for spawning inductions. Some of the gonadal material is squirted into the vicinity of the gills and the first sperm release will generally take place in 1 to 5 minutes, depending upon the species and state of the gonad. It is also possible to take a biopsy extraction and use some of this sample to induce spawning in another clam. Excess gonadal material may be frozen (or freeze-dried) and used in the future.

#### 5.1.2 Serotonin injection

Serotonin-induced spawning of giant clams (Braley 1985, 1986; Crawford et al. 1986; Alcazar et al. 1987) has been successful, particularly for *Hippopus hippopus* and some of the smaller *Tridacna* species. It has been used to induce spawning in *Tridacna derasa* and *Tridacna gigas* with some

success, but particularly when the clams are ripe and ready to release eggs. Sperm is usually released by these species even if eggs are not. Serotonin can be most effective when broodstock have been releasing sperm regularly for several days in a row. When they are injected, especially in combination with a rapid increase in water temperature, the likelihood of a very large spawning (in *Tridacna gigas* this may be up to 500+ million eggs) is increased. The position of the injection is the same as that for a biopsy sample (see Figures 4.2 and 4.3).

A 2 mM concentration of serotonin is suggested. The dosage will vary from the small species (0.5 mL) through to *Tridacna gigas* (2– 4 mL). A 2 mM concentration is made by adding 0.17 g of crystalline serotonin (5-hydroxytryptamine creatinine sulfate complex, Sigma Chemical Co.) in 250 mL seawater (preferably <math>1\ \mu\text{m}</math> filtered). This solution may be kept in the refrigerator for up to one month or until the solution turns a distinct yellow colour. It can be frozen and will keep even longer. The crystalline serotonin should likewise be kept in a refrigerator.

It is good hygiene to wash needles in methylated spirits after injecting each clam and then in freshwater before re-use.

Note that serotonin is a natural neurotransmitter in giant clams and other bivalves. When it is injected into the gonad of a clam it apparently causes the gonad wall to contract starting a process which leads to the release of sperm (and possibly eggs) within a few minutes, much the same as gonad extract induction. Figure 5.1 shows the postulated spawning mechanism.

### 5.1.3 Temperature shock

Rapid temperature changes will often induce spawning in giant clams. As with other methods, this change in temperature stresses the broodstock clam and release of gametes is the result. The temperature change may be done with sun-heated seawater (up to 35°C) or by taking the clams out of the broodstock tank (suitable for all species except *Tridacna gigas*) and lying them on their side for 30 minutes to an hour in the sun. The near lethal temperature for tridacnid clams would be about 35°C. As mentioned above, rapid temperature increase combined with serotonin induction is an excellent method to induce spawning.



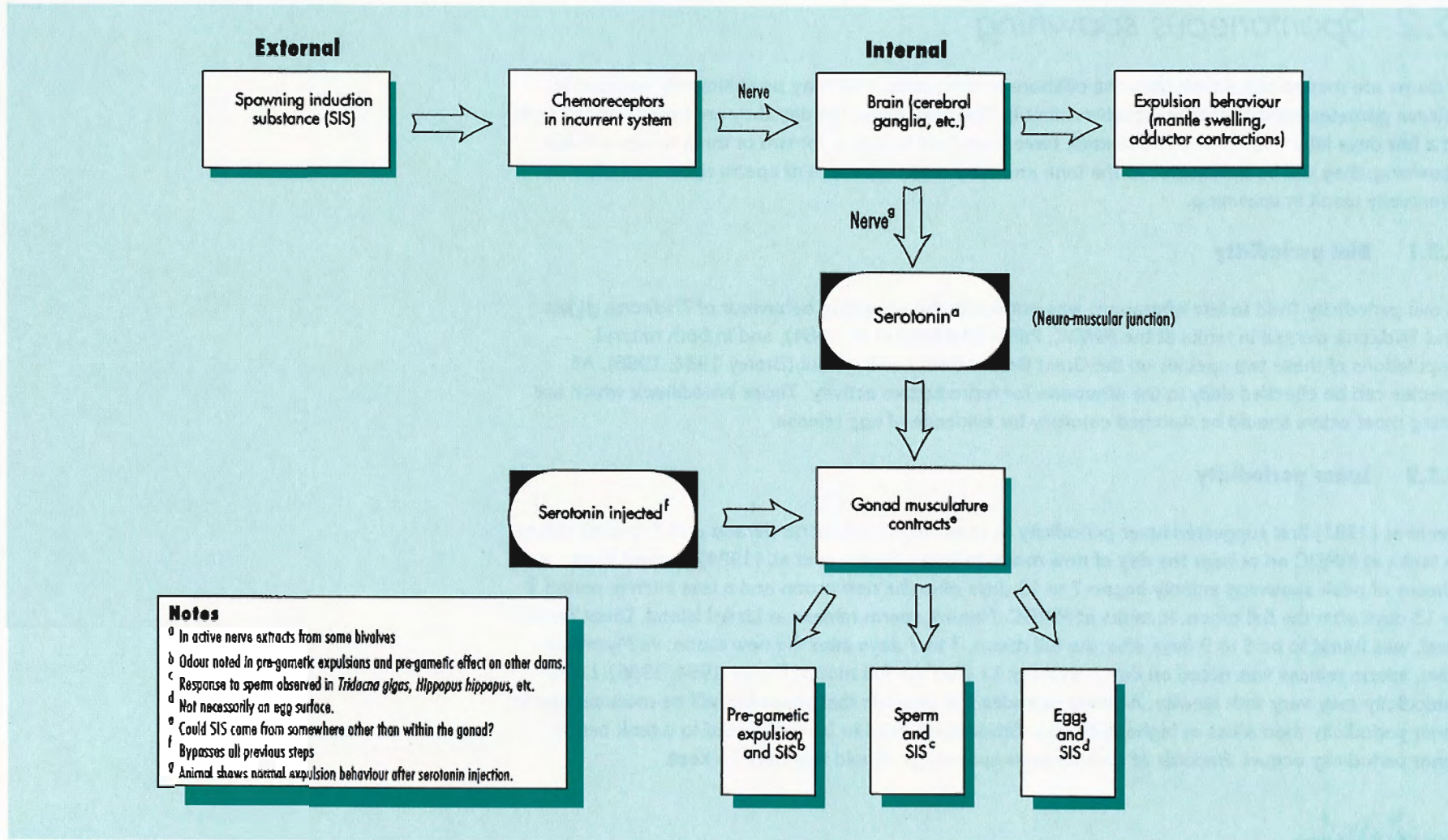


Figure 5.1 Postulated spawning mechanism and the role of serotonin in induction

## 5.2 Spontaneous spawning

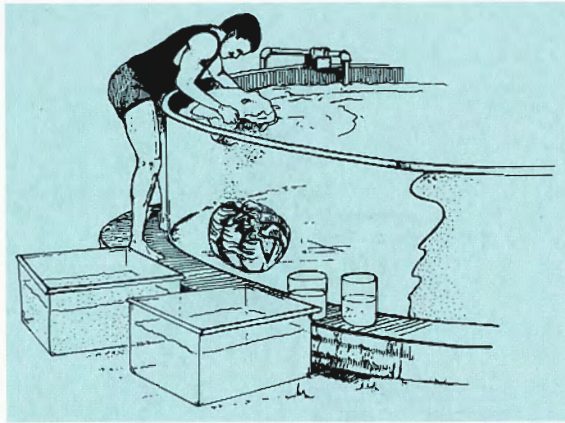
If clams are moved into a tank from the offshore holding area, they may be sufficiently stressed to release gametes without further induction stimuli. This may occur the day they are taken into the tank or a few days later. However, if broodstock have been held in a tank for two or three weeks without spawning, they will be acclimated to the tank and may begin a pattern of sperm release which may eventually result in spawning.

### 5.2.1 Diel periodicity

A diel periodicity (mid to late afternoon) was noticed in the spawning behaviour of *Tridacna gigas* and *Tridacna derasa* in tanks at the MMDC, Palau (Heslinga et al. 1984), and in both natural populations of these two species on the Great Barrier Reef and in tanks (Braley 1984, 1986). All species can be checked daily in the afternoon for reproductive activity. Those broodstock which are being most active should be watched carefully for evidence of egg release.

### 5.2.2 Lunar periodicity

Beckvar (1981) first suggested lunar periodicity in spawning of *Tridacna derasa* and *Tridacna gigas* in tanks at MMDC on or near the day of new moon in Palau. Heslinga et al. (1984) showed lunar phases of peak spawning activity began 7 to 13 days after the new moon and a less intense period 7 to 13 days after the full moon, in tanks at MMDC. Natural sperm release at Lizard Island, Great Barrier Reef, was found to be 6 to 9 days after the full moon, 3 to 7 days after the new moon. At Myrmidon Reef, sperm release was noted on day 8 and day 11 after the full moon (Braley 1984, 1986). Lunar periodicity may vary with locality. At lower latitudes it is possible that spawning will be more regular in lunar periodicity than areas at higher latitudes. Broodstock need to be acclimated to a tank before lunar periodicity occurs. Records of spontaneous spawnings should therefore be kept.



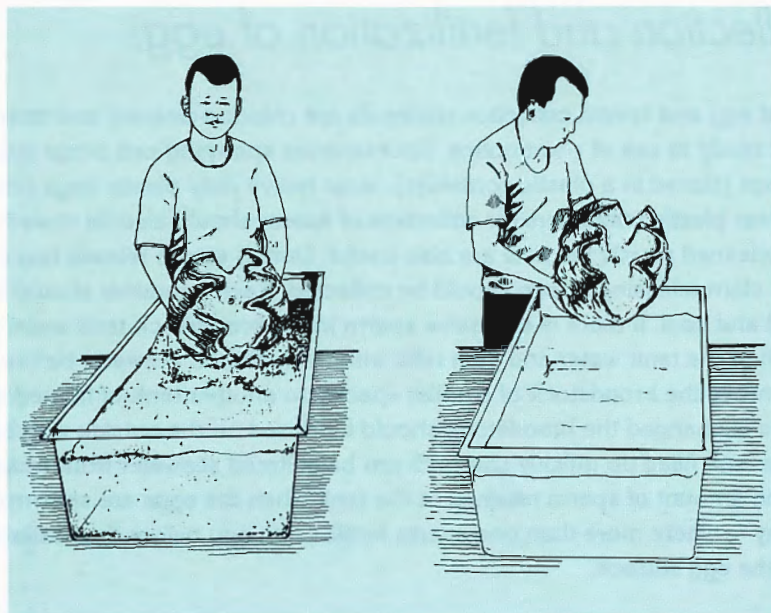
**Figure 5.2** Collection of unfertilized eggs from larger species of clam

### 5.3 Collection and fertilization of eggs

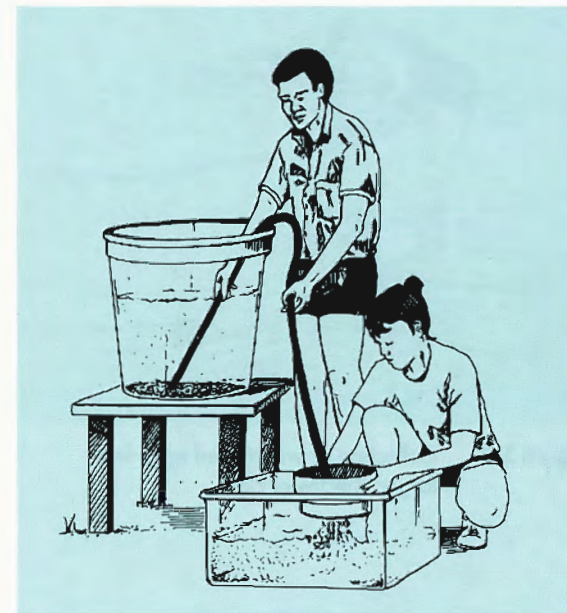
It is essential that egg and sperm collection materials are chlorine-cleaned and stored near the broodstock tank ready to use at short notice. Spontaneous spawning can occur suddenly. Several 25  $\mu\text{m}$  GAF filter bags (stored in a plastic container), large heavy duty plastic bags (clear plastic if possible), and clear plastic containers for collection of sperm should also be stored near the tank. Ten or 20 L chlorine-cleaned plastic buckets are also useful. During sperm release two containers of sperm water from each clam releasing sperm should be collected. Each container should be clearly labelled and kept shaded and cool. If there is excessive sperm in the broodstock tank water it may be wise to drain away much of the tank water and then refill with fresh filtered seawater before egg release commences, or move the broodstock of smaller species to another tank of filtered seawater. If some of the seawater is exchanged the broodstock should be rinsed on the outside with bag-filtered seawater and the tank filled up quickly using 25  $\mu\text{m}$  bag-filtered seawater from more than one tap. This will dilute the amount of sperm retained in the tank when the eggs are spawned. This is done to avoid polyspermy – where more than one sperm fertilizes an egg before the fertilization membrane can be lifted off the egg surface.

When eggs are first noticed these should be collected with a container and looked at under the microscope. When larger numbers of eggs begin to be expelled these should be collected with a large plastic bag with the opening placed underwater above the excurrent siphon of the clam (see Figure 5.2). For smaller species the expulsion of eggs may be caught with a plastic container at the water surface. Alternatively, a spawning clam should first be rinsed with filtered seawater to remove sperm attached to the shell or mantle and transferred to a container with fresh filtered seawater and allowed to release unfertilized eggs (Figure 5.3). When plastic bags are used to collect a dense expulsion of eggs (up to 50+ million eggs per expulsion in *Tridacna gigas*), one plastic tub or bin should be used per expulsion to avoid overcrowding and rapid lowering of oxygen levels in the tub. Egg batches should be aerated while further batches are collected.

Fertilization should occur within 15 minutes of spawning, if possible. If the sperm water is dense with sperm, then only about 30–60 mL is required to fertilize 30 L of concentrated eggs. In the Philippines, it



**Figure 5.3** Collection of unfertilized eggs from smaller species of clam



**Figure 5.4** Siphoning eggs from settling container

It is suggested that 5 mL per L of seawater/eggs be used. The actual amount of sperm water added will depend on the density of eggs and sperm, and requires assessment during spawning. The volume of sperm may be from a mixture of two or more clams, if desired. The plastic tubs or buckets with fertilized eggs should be carried into the laboratory or into the shade and placed on a table or a bench. It should be noted that small volumes of water containing sperm and eggs can easily overheat so that care should be taken not to leave these in the sun; temperatures should not be higher than 32°C for eggs and embryos. The containers should be filled to nearly full with filtered seawater, and the eggs left for about one hour to settle to the bottom. If the eggs are too dense the tub may have to be divided into two before leaving the eggs to settle. If the density of eggs is too high or if they are left too long, the oxygen level in the tub may drop and cause fatalities in the developing embryos. The containers should not be disturbed while eggs are settling. The containers can be checked in the dark with a torch shone

through the side wall of translucent plastic tubs. Most eggs should be settled on the bottom. Have clean nally tubs or other containers on the floor. Siphon the eggs off the bottom through a 200  $\mu\text{m}$  sieve (to remove large debris) directly into the clean nally tubs (see Figure 5.4). It is necessary to suck hard on the tubing when the siphon is started or else the water may be forced back down the tube and sweep the nicely settled eggs off the bottom. A torch held in the dark against the container is about the best way to confirm that all of the eggs have been siphoned off the bottom of one area. Transfer as little of the egg/seawater as possible into new containers; only concentrated eggs are desired. If time is short and the egg water looks reasonably clean it may be more prudent to dispense with the step which allows the eggs to settle. In that case follow on with egg count estimates after fertilization.

#### 5.4 Estimate of egg count

After the concentrated eggs have been siphoned into a clean container the volume of the seawater in the container should be adjusted so that the counts per mL will not be high. For example, if the eggs have been concentrated into 15–20 L it would be wise to top up the container to 50–60 L with

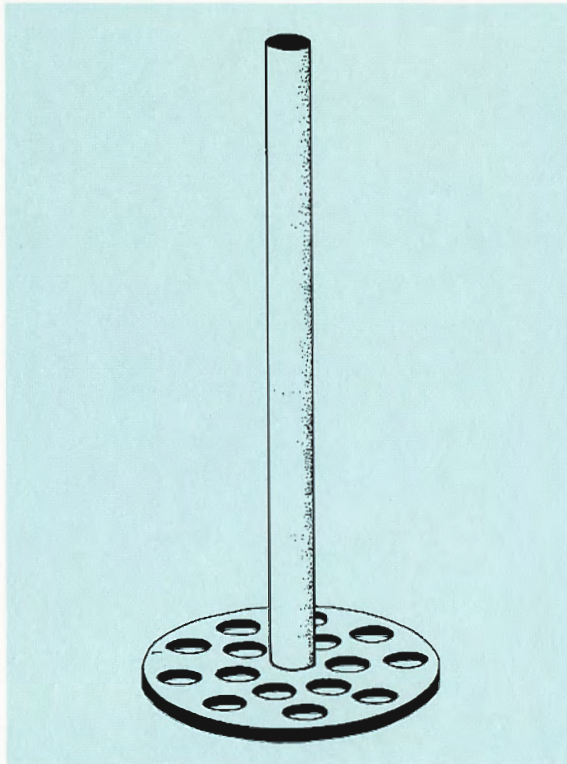


Figure 5.5 Plunger for mixing eggs or larvae evenly

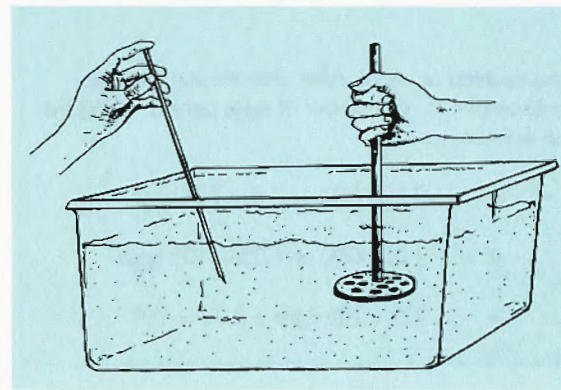


Figure 5.6 Pipetting samples of eggs or larvae

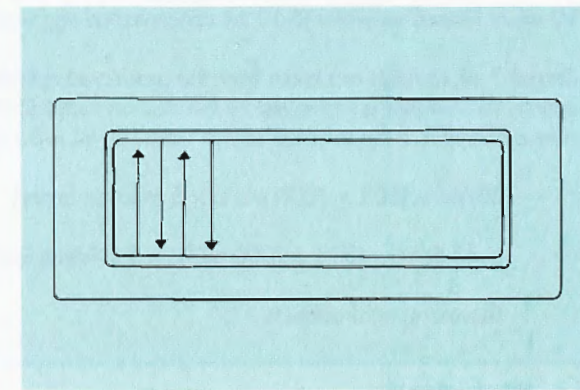


Figure 5.7 Sedgewick Rafter Counting Chamber for estimate of eggs or larvae

**Box 5.1**

*Examples of calculations to determine number of eggs or larvae*

Assume there are about 35 L of egg water collected from a spawning. The eggs are moderately dense. The containers are topped up with filtered sea water to a known volume, say 50 L. The egg water is plunged evenly as ten 1-mL pipette samples are taken. Average counts of eggs are 62/mL  $\pm$  8 s.d. (standard deviation).

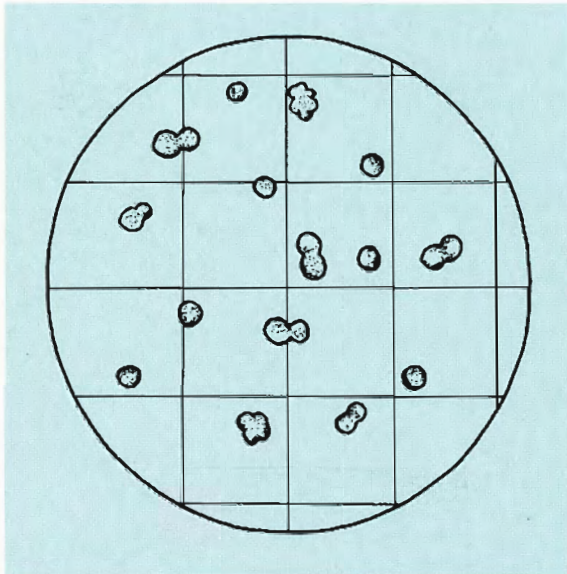
Total number of eggs (or larvae for larval counts):

$$\begin{aligned}
 62/\text{mL} \times (50 \text{ L} \times 1000 \text{ mL/L}) &= 3\,100\,000 \text{ or } 3.1 \times 10^6 \text{ eggs} \\
 (\text{s.d.}) 8/\text{mL} \times (50 \text{ L} \times 1000 \text{ mL/L}) &= 400\,000 \text{ or } 4 \times 10^5 \text{ eggs} \\
 \text{Therefore, total estimate} &= 3.1 \times 10^6 \pm 4 \times 10^5 \text{ eggs.}
 \end{aligned}$$

Suppose the initial 35 L of egg water is very dense with eggs. Even after the containers are made up to 50 L as in the previous example, it will be necessary to dilute samples before counting. Ten 1 mL pipette samples are taken as before but all are placed into a graduated cylinder. If desired, dilute by a factor of 5 adding 40 mL of filtered seawater to this 10 mL of concentrated egg water to give 50 mL total volume, (or if diluting by a factor of 10 add 90 mL of filtered seawater to 10 mL concentrated egg water).

Stirred 1 mL samples are taken from the graduated cylinder and counted as usual. After determining average counts, this number is multiplied by the dilution factor (5 in this example) to get number of eggs per mL. Using the above example, if the average counts were 30/mL  $\pm$  5 s.d., the estimate is:

$$\begin{aligned}
 30/\text{mL} \times (50 \text{ L} \times 1000 \text{ mL/L}) \times 5 \text{ (dilution factor)} &= 7\,500\,000 \text{ or } 7.5 \times 10^6 \text{ eggs.} \\
 (\text{s.d.}) 5/\text{mL} \times (50 \text{ L} \times 1000 \text{ mL/L}) \times 5 \text{ (dilution factor)} &= 1\,250\,000 \text{ or } 1.25 \times 10^6 \text{ eggs} \\
 \text{Therefore, total estimate} &= 7.5 \times 10^6 \text{ eggs} \pm 8.75 \times 10^5
 \end{aligned}$$



**Figure 5.8** Infertile eggs and fertilized eggs showing two and four cell division

(1 or 5  $\mu\text{m}$ ) filtered seawater. The temperature of the filtered seawater should be close to that of the water in which the eggs or developing embryos have been, and include aeration from this point onward. Use a plunger with a slow up and down motion (Figure 5.5) to evenly mix the eggs in the container. A 1 mL pipette is used to take samples from this container (Figure 5.6). The 1 mL samples are put onto a 1 mL volume Sedgewick Rafter Counting Chamber (Figure 5.7). The eggs are counted against the grid pattern of the counting chamber. Alternatively, a tissue culture plate with 24 cells in it can be used to count 0.5 mL volume samples (Heslinga et al. 1990). If a tissue culture plate is used, the bottom of the plate can be scratched using a straight-edge guide so counts of eggs are easier to follow. At least eight samples should be counted to make a fairly accurate estimate of the number of fertilized eggs. The mean  $\pm$  standard deviation of the counts in the chambers is multiplied by the volume in mL of the egg/seawater mixture in the container to give the estimated total number of eggs (Box 5.1).

To determine the fertilization rate of the eggs in the samples at 2 hour post-fertilization, count 100 random eggs and score those which are dividing normally (at 2 hour post-fertilization the eggs should be in the 2-cell stage and some may be starting in the 4-cell stage) (Figure 5.8). At least three counts should be done to determine the mean percentage fertilization rate. This percentage can then be used to estimate the actual number of eggs developing as embryos. If the fertilization rate is greater than 85–90% this indicates that the larvae should be a fairly good batch. If the fertilization rate is less than 50% a very poor batch of larvae would be expected.

## Larval rearing

### 6.1 Hatching and larval rearing methods

The traditional method of rearing larvae is to stock fertilized eggs into larval rearing tanks at densities of 1 or 2 eggs per mL. Aeration is provided but the amount of aeration varies at different culture facilities. A newer method of 'selection' has been developed at JCUOIRS. This requires the use of 'hatching' tanks for the embryo and trochophore to D-stage veliger larvae. After the veliger stage, healthy swimming larvae are selected and transferred to a larval rearing tank where they remain until settlement and possibly through the land nursery phase. Most of the methods discussed below refer to this selection method, but some reference is made to the traditional non-selection method. Either method can be used. Figure 6.1 shows different hatching and larval rearing methods.

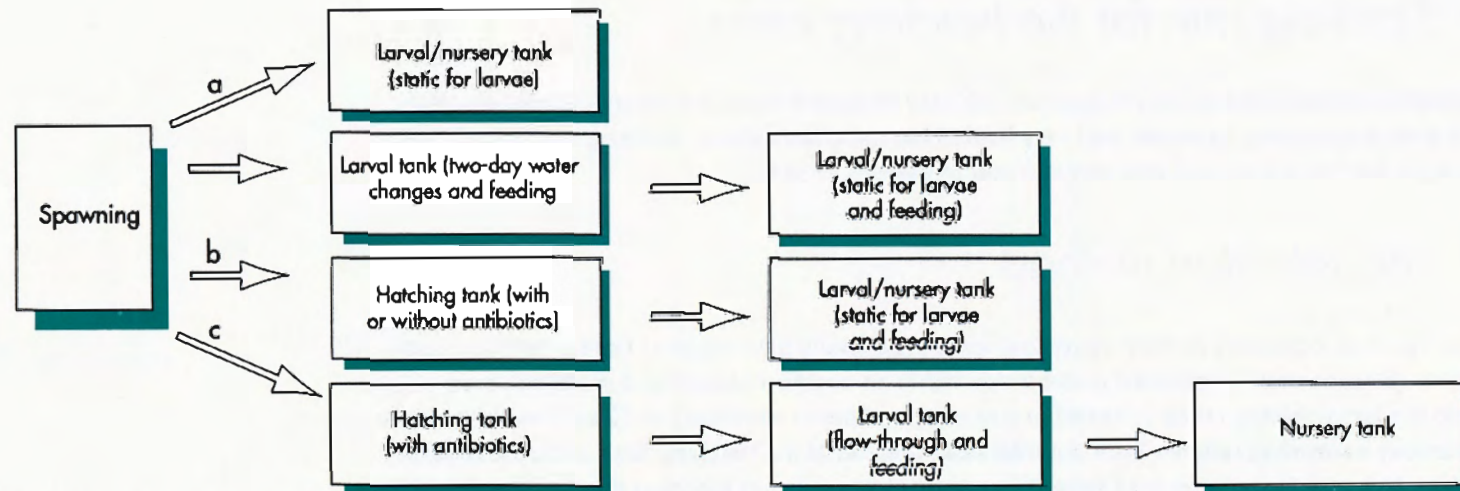


Figure 6.1 Different hatching and larval rearing methods: (a) Heslinga et al. 1984; (b) Crawford et al. 1986; (c) Braley et al. 1988, Heslinga 1990.



The type of tank used for a hatching tank may be circular or rectangular but a rectangular tank will often provide more bottom surface area per given volume. There are a number of rectangular tanks in Pacific countries which are Japanese-made, blue gel coat inside and white outside; the inside dimensions are 2.4 m long  $\times$  0.99 m wide  $\times$  0.75 m deep. If filled to about 0.7 m they hold about 1650 L and have a bottom surface area of about 24 000 cm<sup>2</sup>.

The hygiene and handling of the larval hatching and rearing tanks is most important. Equipment should never be used in one tank and then in another tank without being cleaned. If disease organisms are present in one tank, then they will be transferred to a clean tank and cause mortalities of larvae. All equipment (and hands) should be rinsed by chlorine and freshwater when shifting from one tank to another. Some large-scale hatcheries in temperate regions have a whole set of equipment for each tank and never use it with another tank. This can greatly increase capital costs so chlorine rinsing should be part of the protocol. Think on a microscopic scale when working around larvae and this will bring care to movements which might otherwise contaminate a larval batch.

### 6.2 *Stocking rate for the hatching tanks*

A conservative stocking rate of 20–25 eggs per mL may be used if there are plenty of hatching tanks. If there is a large spawning, however, and very limited hatching tank space, stocking can be at 30–40 fertilized eggs per mL when used with aeration and antibiotics (Box 6.1).

### 6.3 *The selection method*

'Selection' refers to collecting healthy swimming larvae (generally new veligers) from a hatching tank onto a sieve (80  $\mu$ m mesh) positioned under water within an overflow bucket and stocking these larvae into the larval rearing tanks (cleaned and containing filtered seawater). A 12 mm siphon hose is used to remove swimming veligers from the mid-water column of the hatching tank and collect them on the sieve. It is wise to use a second sieve (53  $\mu$ m) in another bucket catching the overflow from the 80  $\mu$ m sieve. Small veligers will be caught on the 53  $\mu$ m sieve, but this will also catch trochophores.

**Box 6.1***Examples of calculations for stocking of fertilized eggs*

Assume there is a mean estimate of  $1.25 \times 10^8$  fertilised eggs in a 100 L volume. The aim is to stock eggs at 35/mL in 500 L rectangular tanks, which are useful as hatching tanks.

The calculation of how much concentrated egg volume is needed per hatching tank can be done in either of two ways.

$$\begin{aligned}
 \text{(i)} \quad & 35/\text{mL} (500 \text{ L} \times 1000 \text{ mL/L}) & = & 17\,500\,000 \text{ or } 1.75 \times 10^7 \text{ eggs/tank.} \\
 & (1.25 \times 10^8 \text{ eggs}) / (1.75 \times 10^7 \text{ eggs/tank}) & = & 7.1 \text{ tanks or 7 tanks required.} \\
 & (1.75 \times 10^7 \text{ eggs}) / (1.25 \times 10^8 \text{ eggs}) \times 100\% & = & 14.0\% \\
 & 100 \text{ L concentrated eggs} \times 0.14 & = & 14.0 \text{ L egg water per hatching tank.}
 \end{aligned}$$

(ii) The following formula may be used:

$$D_1 V_1 = D_2 V_2, \text{ where}$$

$V_1$  = unknown volume of concentrated egg water needed per hatching tank

$$\begin{aligned}
 D_1 & = \text{mean estimate of fertilised eggs per mL} = 1.25 \times 10^8 \text{ eggs} / (100 \text{ L} \times 1000 \text{ mL/L}) \\
 & = 1250 \text{ eggs/mL}
 \end{aligned}$$

$$\begin{aligned}
 V_2 & = \text{volume of each hatching tank} = 500 \text{ L} \times 1000 \text{ mL/L} \\
 & = 500\,000 \text{ mL}
 \end{aligned}$$

$$\begin{aligned}
 D_2 & = \text{the desired stocking rate of fertilised eggs per mL} \\
 & = 35 \text{ eggs/mL.}
 \end{aligned}$$

$$\begin{aligned}
 \text{So } V_1 & = (35) (500\,000) / 1250 \\
 & = 14\,000 \text{ mL} \\
 & = 14.0 \text{ L egg water per hatching tank.}
 \end{aligned}$$

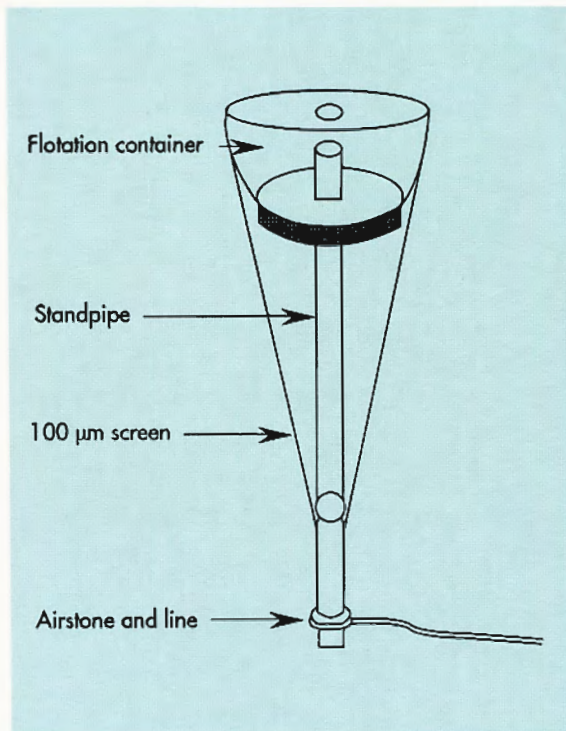
which are late developers. If only a small percentage of the larvae caught on the 53  $\mu\text{m}$  sieve are veligers then it is best to discard the late developing trochophores and use only the 80  $\mu\text{m}$  sieve. For the smaller species of tridacnids the 53  $\mu\text{m}$  sieve should always be used because even healthy veliger larvae will be caught on this size screen.

The traditional non-selection method is less hygienic because the fertilized eggs are placed directly into the larval rearing tank after spawning and unfertilized eggs or dead embryos remain on the bottom of the larval rearing tank throughout the larval period. This may cause an increased bacterial load for the healthy larvae.

### **6.3.1 Selection with antibiotics and/or lowered temperature**

Antibiotics must be used on the fertilized eggs and embryos of giant clams to reduce bacteria, especially on the bottom, while the eggs develop to trochophore larvae (12 to 18 hours after fertilization). The single most useful antibiotic is streptomycin sulfate administered at about 10 ppm (10 g/1000 L filtered seawater). It is relatively cheap compared to other antibiotics, effective on gram positive and gram negative bacteria and is not dangerous to humans, as is chloramphenicol (a serious carcinogen for a small percentage of people). Other antibiotics which have been used, often in combination with streptomycin, are neomycin and penicillin G. If combined, the total concentration should still be about 10 ppm. The hatching tanks should be located in an air-conditioned room, or under a canopy to maintain the temperature at about 26 to 30°C. Development is still quite rapid at this temperature but bacterial growth may be slowed a little. The hatching tanks should be covered with 90% shade cloth if outdoors (to keep out insects and debris and to cut down on ultra-violet light and overheating), or with a plastic sheet if indoors. The tank should be aerated moderately with fine bubbles; sufficient aeration to keep the eggs and larvae in suspension. If a raceway is used the airline material is best laid down in the centre along the length of the raceway. Rubber-based aeration tubing called waterwik (for air compressors) and aquapore (for air blowers), provide an excellent source of fine bubbles.

When spawning *Tridacna derasa* at higher latitudes, the late winter-early spring spawning also involves night and day fluctuations in water temperature (23 to 28°C). This may not be a problem for



**Figure 6.2** Flow-through cone screen used in larval tank

this species, but for mid-summer spawning species the temperature should not be allowed to fluctuate greatly.

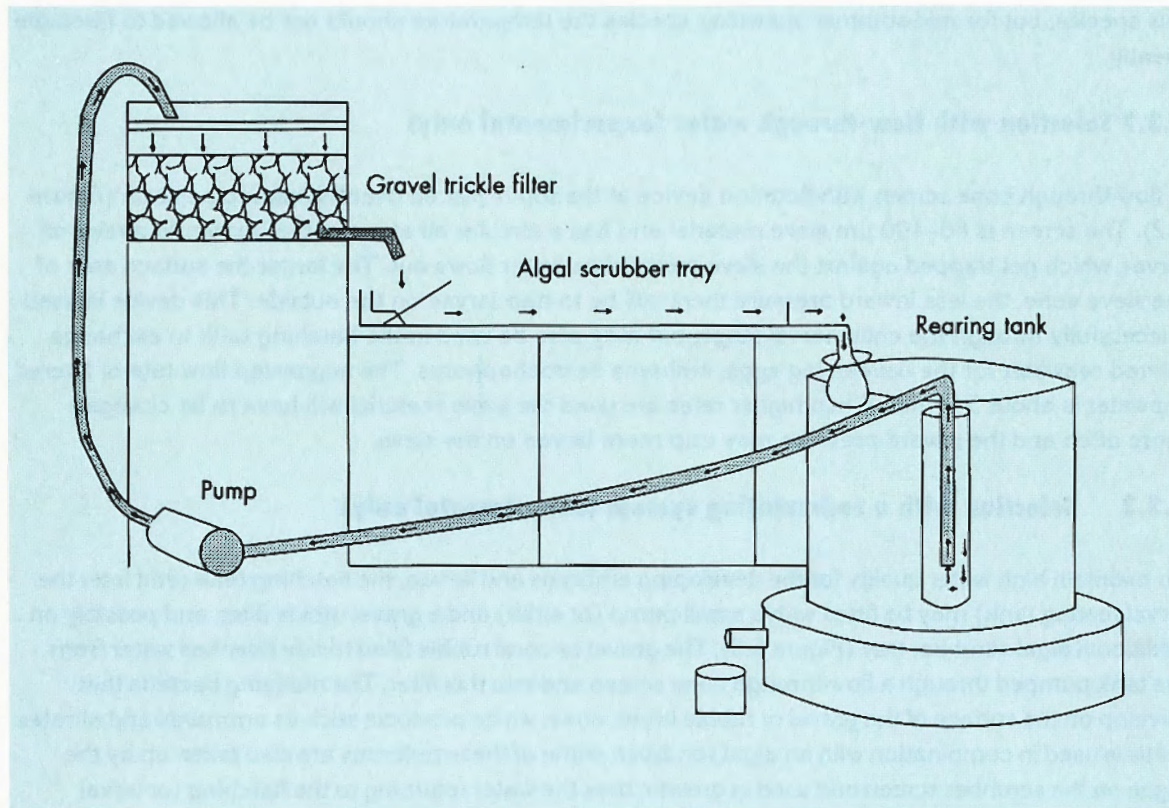
### 6.3.2 Selection with flow-through water (experimental only)

A flow-through cone screen with flotation device at the top is placed over the standpipe drain (Figure 6.2). The screen is 80–100 µm sieve material and has a circular air stone at the bottom to sweep off larvae which get trapped against the sieve material as water flows out. The larger the surface area of the sieve cone, the less inward pressure there will be to trap larvae on the outside. This device is used successfully through the entire larval stage, but may also be used in the hatching tank to exchange filtered seawater for the developing eggs, embryos or trochophores. The suggested flow rate of filtered seawater is about 5 L/min. When higher rates are used the sieve material will have to be changed more often and the inward pressure may trap more larvae on the sieve.

### 6.3.3 Selection with a recirculating system (experimental only)

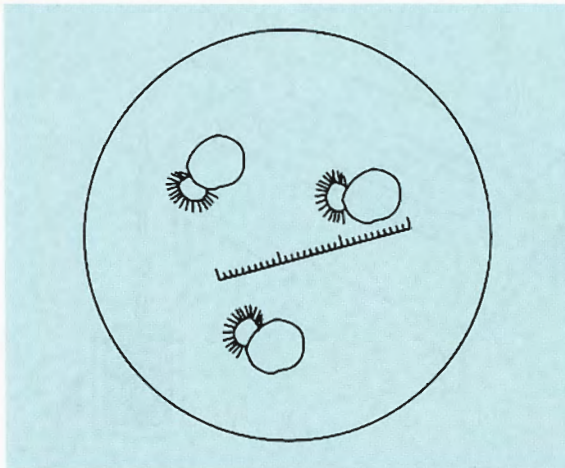
To maintain high water quality for the developing embryos and larvae, the hatching tank (and later the larval rearing tank) may be fitted with a small pump (or airlift) and a gravel trickle filter, and possibly an additional algal scrubber tray (Figure 6.3). The gravel or coral rubble filled trickle filter has water from the tank pumped through a flow-through cone screen and into this filter. The nitrifying bacteria that develop on the surface of the gravel or rubble break down waste products such as ammonia and nitrates. If this is used in combination with an algal scrubber, some of these nutrients are also taken up by the algae on the scrubber screen and used in growth; thus the water returning to the hatching (or larval rearing) tanks is somewhat nutrient cleared. This can reduce stress in the larvae and may result in better survival.

In all cases of selection the situation in the hatching tank should be assessed after 24 hours when all the trochophores should be swimming. The aeration should be turned off for 1 hour and the dead eggs and embryos carefully siphoned off the bottom of the tank (avoiding rapid movement of the siphon hose which will stir up the dead material). The amount of water removed by siphoning the bottom should be replaced if it is a substantial volume, and if there are large numbers of larvae the

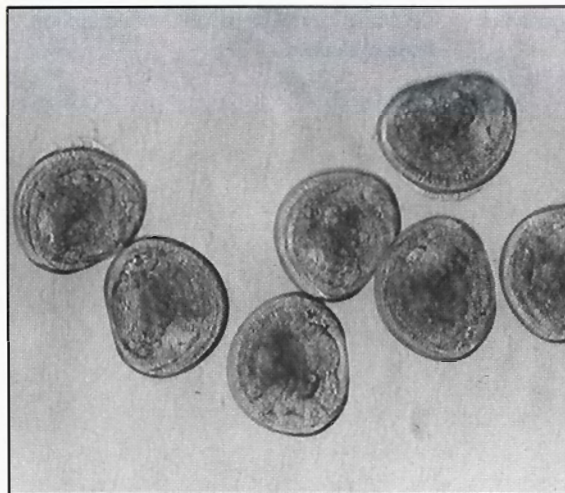


**Figure 6.3** Recirculating system for a tank showing a gravel and trickle filter and an algal scrubber tray (based on a design by Dr Dave Sutton of James Cook University)

volume of water should be increased. More antibiotic may be added to compensate for any substantial new volume of filtered seawater added. The tank should be aerated again. If there are large numbers of live trochophores and little observable dead on the bottom of the hatching tank, the tank can be left undisturbed until the following day.



**Figure 6.4** Representation of D-stage veliger larvae under a microscope



**Figure 6.5** Photomicrograph of older veliger larvae

## 6.4 Retrieving swimming veligers from selection and estimates of counts

If spawning takes place in mid-afternoon then the larvae should become veligers by early morning of the second day after the spawning (40 hours after fertilization). The numbers of larvae in the water column can be viewed in the morning with a torch, before the sun becomes too bright. If the numbers look comparable to the numbers of trochophores from the previous day, there is a good batch of larvae and they must be taken out of the hatching tank as soon as possible, preferably before they are 48 hours old. In some cases there will be mostly D-stage veligers (Figures 6.4 and 6.5) but there may still be some trochophores or the trochophore-veliger transition stage. If the percentage of veligers is not high it is recommended to wait several hours before retrieving the larvae.

If the veligers look evenly distributed in the tank (with low aeration), at least 10 × 1 mL aliquot samples can be taken and counted on the Sedgewick Rafter Counting Chamber (see section 5.4). Thus, an estimate of total numbers of swimming veligers can be made before they are retrieved. This saves having to stress the larvae further by concentrating them into a smaller container for counting before distribution to larval rearing tanks.

A large 80–88 µm sieve with high side walls is used when siphoning larvae from the hatching tank (Figure 6.6). It is preferable to have the level of the sieve material below the level of water in a tray or plastic tub so that the larvae are not drained dry on the sieve. The overflow water from the 80–88 µm screen should be checked for larvae and a secondary 53 µm screen can be used to catch these in the overflow water. When the number of larvae gets too concentrated on the sieve (they will look like piles of fine white sand grains) the sieve is removed and larvae rinsed off the sieve into a container with filtered seawater. The larvae are either put directly into the larval rearing tank if counts were done in the hatching tank or left to sit in a large aerated container (e.g. 50 L plastic bin) until all the larvae have been retrieved. These are then counted for an estimate of numbers. As mentioned earlier, the larvae should be kept out of the sun to avoid overheating, and there should be no temperature changes between containers. When siphoning out from the hatching tank it is not wise to drain lower than 5 cm from the bottom of the tank. This avoids dead or dying larvae contaminating the healthy

swimming veligers selected. This bottom water may be drained into containers and left to sit for an hour or so without aeration to see if there are some live larvae at the surface that may be retrieved.

### 6.5 Stocking rate for the larval rearing tanks

Larval rearing tanks may be rectangular raceways (fibreglass, cement, ferrocement, plastic liner) or circular type tanks. If circular tanks are chosen there will be either a central drain or a drain on the opposite side of the tank from the seawater inlet. Circular tanks have the least wall area. Circular fibreglass or cement tanks of 3000–4000 L (3–4 t) with central drains and 10 000 L (10 t) cheap 'splasher' pools with plastic liners work well. A side drain is used with the 10 t tanks to enable easy access to the flow-through cone screen as the pools are 4.5 m diameter by 0.9 m deep. Raceway tanks are a favourite design in many hatchery–nurseries. In Palau at the MMDC, cement block raceways are recommended (Heslinga et al. 1990). In the Philippines and at the ICLARM–CAC in the Solomon Islands, raceways have been made of a marine plywood or coconut log frames with canvacon (molded plastic liner) laid within the frames. Typical volumes of raceways at existing giant clam hatcheries and nurseries range from about 2 to 20 t, but the most usual volume is about 8 to 10 t.

In the non-selection system, fertilized eggs are added at the rate of 2 per mL. Selected veliger larvae are stocked at 1 per mL in semi-intensive culture tanks. When culturing larvae intensively in circular, conical bottom 1 to 5 t tanks, the tanks can be stocked with veliger larvae at the rate of 3 to 10 per mL, but most success has been with about 3 to 4 per mL. Recent work at the ICLARM–CAC suggests that a higher density is possible when antibiotics are used constantly throughout the larval period. However, a more judicious use of antibiotics during the hatching phase only is recommended. As noted earlier, the seawater flow rate should be 5 L/min or greater (about one turnover per day) for culture tanks with a flow-through cone screen. There should be several turnovers of the tank water each day when densities of 3 to 4 larvae per mL are being cultured.

In static culture there are two options: completely static where larvae are left in the same culture water throughout the larval phase; and static with water changes every day or other day. With the water change option the larvae have to be siphoned out onto a sieve every day or two (either through a

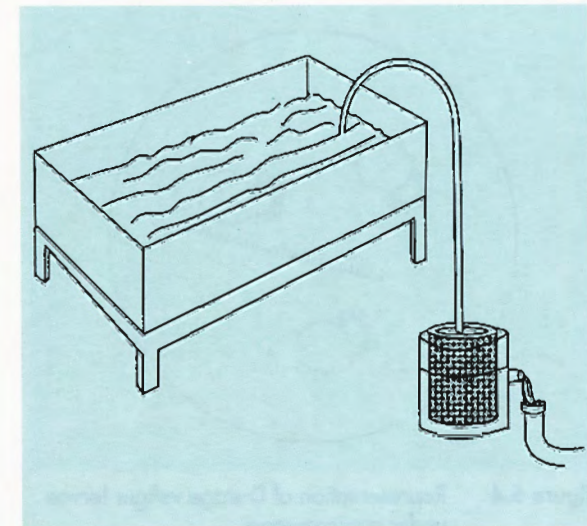


Figure 6.6 Draining larvae from tank with a siphon hose and sieve

siphon hose or bottom valve on a tank), the tank chlorine-cleaned, rinsed and refilled before restocking the larvae. Although this method works, it is stressful on the larvae and a lot more work for the clam researchers than a flow-through system. The MMDC in Palau has recently adopted a selection method similar to the JCUIRS method (Heslinga et al. 1990) but likewise uses an older non-selective method where the larval and land nursery stages are spent in 10 t cement raceways. The seawater level in the tank is raised gradually through the larval stage until water is flowed through after 10 days. This method is less intensive for workers but generally only produces 5000–10 000 juveniles at 90 days.

In the Philippines, the retrieved veligers are placed in larval rearing tanks with filtered seawater plus low aeration. The system remains static for three to four days and then has a gentle flow-through for the next five days. A filter cloth (75 to 80  $\mu\text{m}$ ) is placed over the stand pipe drain or a flow-through conical screen with flotation device may be used. As soon as the larvae have metamorphosed and settled, the flow rate is increased gradually and the filter cloth can be removed.

Static culture with water changes are still most commonly used for temperate bivalve hatcheries. The temperature controlled hatchery rooms, high density of larvae per tank (10 to 50 per mL), and level of control of water quality make this a very suitable option despite the labour intensity.

## 6.6 Checking on swimming larvae

It is easiest to check larval tanks at night by shining a bright torch (flashlight) into the water column at various points around the tank. Larvae should be fairly evenly distributed points of light with no other larval-size material in the water column. Very fine-grained microalgae may be seen if the larvae are being fed. If slimy strings are seen in the water these are bacterial strings which can rapidly develop in the water column, fouling larvae in the strings. When this appears it is easy to lose the whole larval batch. If caught early, it may be possible to drain the whole tank, collect the larvae and set them in a container with antibiotic whilst cleaning the tank with chlorine and refilling. Alternatively, the bacterial strings can be collected with a 1 mm mesh net run through the water column. Another common bacteria seen in larval tanks forms pink patches on the bottom of the tank. It develops on dead



## HATCHERY AND NURSERY CULTURE OF GIANT CLAMS

---

embryos and larvae. If the tank is left in full sunlight, this will kill off or bleach away some of the pink bacteria. It is wise to siphon off the bottom in the vicinity of the pink patches. Larval tanks should be checked each night to look for reduction in numbers, either indicating stress and death of larvae or if it is near the end of the pediveliger stage it will indicate settlement (between days 6 to 10, dependent upon temperature).

During the day, larvae in the tank can be checked most easily with a black disc held under the water. The larvae are visible in front of the disc. Also, larval samples can be taken from the tank by concentrating some on a small 100  $\mu\text{m}$  sieve and rinsing into a Sedgewick Rafter Counter for microscopic viewing.

Heavy rain may lower the salinity in outdoor larval rearing tanks. In this instance, the flow-through system is most practical as the aeration can be shut off to avoid mixing the freshwater and seawater and the less dense freshwater can then flow out the overflow through the flow-through screen.

## Larval feeding

Giant clam larvae are planktotrophic, as are the majority of bivalve mollusc larvae. Each egg has only a small amount of yolk to provide for the embryo's development and nutrition to the swimming veliger stage. Lecithotrophic larvae, such as those of the trochus or top shell *Trochus niloticus*, have large yolky eggs and the larvae do not need to feed through the short larval stage (three days). Although it is possible to obtain some juvenile clams when the larvae have not been fed, the numbers are much lower than when food has been given. Also, the importance of dissolved organic matter in the seawater, or of nanoplankton, both of which will go through nominal 1  $\mu\text{m}$  GAF filter bags, has not been determined for clam larvae.

### 7.1 Algae

The usual food of bivalve larvae is unicellular algae, between 2 to 10  $\mu\text{m}$  in size. In trials of dietary preference of giant clam larvae, naked flagellate algae were preferred to diatoms and growth was best with flagellate algae (Fitt et al. 1984; Braley 1986; Southgate 1990). If unfed veliger larvae are placed into raw seawater, unicellular algae appears within the gut of the larvae after 30 to 60 minutes. The amount of algae needed to feed a large concentration of larvae is in the range of 1000 to 15 000 cells per mL. The larvae swim and feed with the cilia on the velum so the algae should be in a dense enough concentration that the larvae can easily clear them from the water column just by swimming randomly.

#### 7.1.1 Monospecific cultures

Most hatcheries in temperate or tropical areas require monospecific unicellular algal cultures for their larval rearing needs. A considerable amount of time is needed to set up and maintain these cultures. The handling of monospecific cultures requires careful attention to detail and hygiene, and the person

responsible requires specific training. For further details about the classical monospecific algal culture see Ukeles 1971, Walne 1974 and Guillard 1975. Further information on setting up a monospecific culture can be obtained by writing to Dr Shirley Jeffrey, CSIRO Division of Fisheries, Hobart, Tasmania. CSIRO also supplies stock algal cultures for a nominal fee.

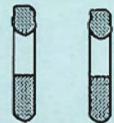
Figure 7.1 is a diagram of the steps required to go from the stock cultures to 100 L cultures in fibreglass cylinders or in plastic bags. The algal medium formula, a modified Guillard's F2 medium, is described in Box 7.1. Stock cultures should be changed every two weeks in the tropics and the culture temperature in the algal room should be maintained by air-conditioning at about 26 to 27°C. UPMSI in the Philippines has had success maintaining monospecific cultures of algae using 10 L barrel-shaped plastic containers stacked on shelves. The preferred food in the Philippines is *Isochrysis galbana* fed at 5 L of high density algae culture into a 3 t tank.

A homemade laminar flow cabinet for sterile transfer of algae is shown in Figure 7.2. The risk of contaminating stock cultures with other algae or protozoan ciliates is virtually eliminated with the use of a laminar flow cabinet.

Because of the time involved, and the careful attention which must be given to hygiene, it is not recommended that a new giant clam hatchery try to set up this type of algal culture to start with. A simpler method more appropriate to the needs of a giant clam hatchery may be used. If a hatchery has been running smoothly for some time using one of the other feeding methods, consideration could be given to setting up a monospecific culture.

### 7.1.2 Greenwater cultures

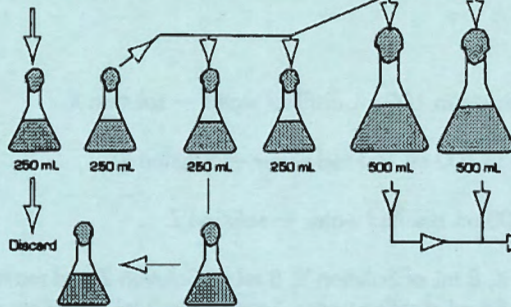
This simpler system for culture of unicellular algae should be promoted in new hatcheries, especially ones in remote areas. A 10 µm or 25 µm GAF filter bag is used to fill a chlorine-cleaned and rinsed tank (say a 1 t tank) half full (500 L) of seawater. Dix Mix algal medium (Box 7.1) is used at the rate of 0.5 mL/L of filtered seawater (this is half the rate used for densely growing cultures of algae). Vigorous aeration should be provided. After several weeks, algae which have passed through the filter bags will have increased in numbers sufficiently to be discerned as a slight colour change in the



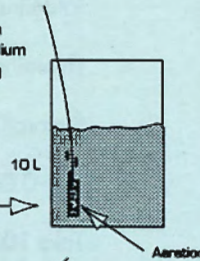
**Step 1**  
25 mL starter algal cultures  
(e.g. supplied from CSIRO)

**Step 2**  
Inoculate 2 X 250 mL  
flasks from starter  
algal cultures

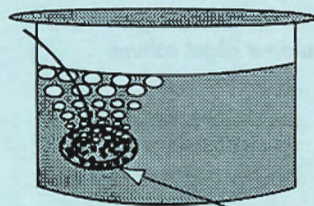
**Step 3** Inoculate into 250 and 500 mL flasks



**Step 5**  
Add 1 L of culture from  
Step 3 into 9 L of medium  
in a plastic culture bag

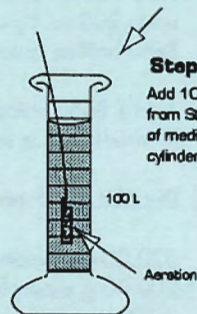


**Step 4**  
Successive inoculations into small culture  
flasks to maintain stock cultures



**Step 7**  
Add 100 L of culture  
from Step 6 into 1000 L  
of medium in an outdoor  
fibreglass tank  
Add more medium ( to  
3000 L) as the culture  
develops

Vigorous aeration



**Step 6**  
Add 10 L of culture  
from Step 5 to 90 L  
of medium in a fibreglass  
cylinder

**Box 7.1**

*Algal medium formulae*

**(i) Modified F2 medium**

**Stock solution**

NaNO<sub>3</sub>: 30 g of NaNO<sub>3</sub> in 200 mL distilled water. Separate in 2 mL quantities in Bijou bottles, autoclave and store — call this solution A.

NaH<sub>2</sub>PO<sub>4</sub>: 2 g of NaH<sub>2</sub>PO<sub>4</sub>·2H<sub>2</sub>O in 200 mL distilled water. Separate in 2 mL quantities in Bijou bottles, autoclave and store — call this solution B.

**Trace metals**

CuSO<sub>4</sub>: 0.196 g of CuSO<sub>4</sub>·5H<sub>2</sub>O

ZnSO<sub>4</sub>: 0.440 g of ZnSO<sub>4</sub>·7H<sub>2</sub>O

CoCl<sub>2</sub>: 0.200 g of CoCl<sub>2</sub>·6H<sub>2</sub>O

MnCl<sub>2</sub>: 0.360 g of MnCl<sub>2</sub>·4H<sub>2</sub>O

Na<sub>2</sub>MoO<sub>4</sub>: 0.126 g of Na<sub>2</sub>MoO<sub>4</sub>·2H<sub>2</sub>O

Mix these five trace metals together and add to 100 mL distilled water — call this solution T.

Take 1 mL of solution T and dilute it to 100 mL with distilled water. Separate in 2 mL quantities in Bijou bottles, autoclave and store — call this solution C.

**Buffer**

Fe citrate : 1.8 g of Fe citrate

Citric acid: 1.8 g of citric acid

Add both chemicals together to 200 mL distilled water. Separate in 2 mL quantities in Bijou bottles, autoclave and store in the fridge — call this solution D.

**Vitamins**

Thiamine: 0.04 g of Thiamine in 100 mL distilled water — solution X.

Biotin: 0.005 g of Biotin in 100 mL distilled water — solution Y.

B<sub>12</sub>: 0.005 g of B<sub>12</sub> in 100 mL distilled water — solution Z.

Take 100 mL of Solution X, 8 mL of Solution Y, 8 mL of Solution Z and make it up to 200 mL by adding 84 mL distilled water. Separate in 2 mL quantities in Bijou bottles, autoclave and freeze — solution E.

Add 1 Bijou bottle each of solution A,B,C,D,E, to 2 L autoclaved seawater (filtered). This is solution F2.

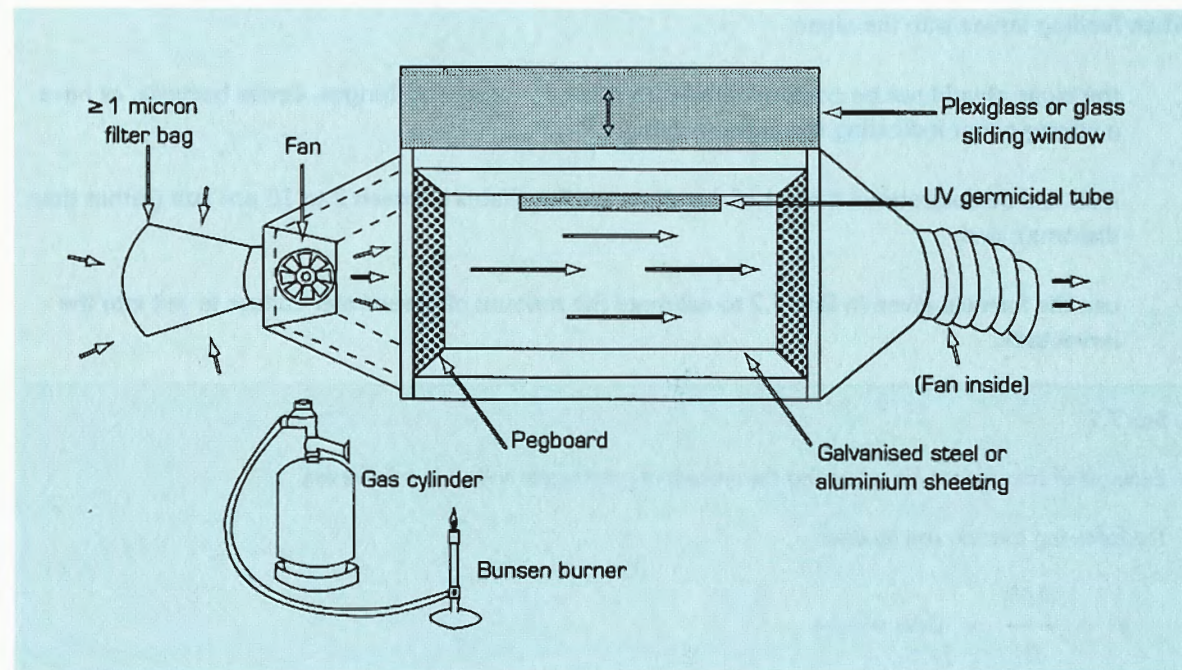
**(ii) Dix Mix algal medium for large-scale or outdoor algal culture**

520.00 g ammonium sulfate

200.00 g superphosphate

3.72 g thiamine HCl (vitamin B<sub>1</sub>)

Crush up fertilisers into powder form as much as possible. Add to 10 L of warm tap water and finally add Vitamin B<sub>1</sub>. Stir and store with lid closed on bucket. Use 1 mL per L filtered seawater.



**Figure 7.2** Homemade algal laminar flow transfer cabinet

seawater. The culture should be checked daily from a small sample taken and placed on a haemocytometer for counts of the algal cells (Figures 7.3 and 7.4). A haemocytometer is a useful tool for checking the condition of the algae; more sophisticated particle counting machines only indicate the number of particles of a certain size that pass through the counter. With a haemocytometer it is possible to see if other algae have contaminated the sample (in monocultures), the activity of the flagellate algae, or whether larger ciliated protozoans have contaminated the culture. Counts are done within the central 25 squares on each side of the haemocytometer. If 30 algae are found within these squares and 26 algae within the grid on the other side of the haemocytometer, then the mean of 28 algae is multiplied by 10 000 ( $10^4$ ) to give  $2.8 \times 10^5$  cells/mL.

When feeding larvae with the algae:

- the algae should not be contaminated with ciliated protozoans, fungus, dense bacteria, or have a strong odour indicating the algae is dying;
- it should be determined if most of the algae are flagellates between 2 to 10 µm size (rather than diatoms); and
- use the formula given in Box 7.2 to estimate the amount of greenwater culture to put into the larval tank.

### Box 7.2

Example of calculations for estimating the amount of greenwater culture to feed larvae

The following formula can be used

$$V_1 = \frac{D_2 V_2}{D_1} \text{ or } D_1 V_1 = D_2 V_2$$

where:

$V_1$  is the unknown volume (in litres) of algal culture water needed to put into the larval tank (in this example it works out to 357 L);

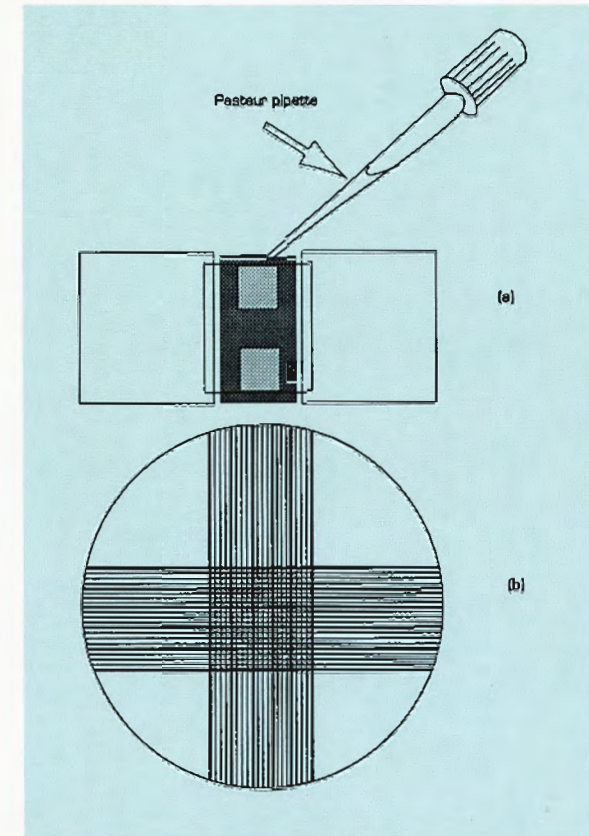
$D_1$  is the estimated density of the algal culture water (say  $2.8 \times 10^5$  cells/mL);

$V_2$  is the volume of the larval culture tank (say a 10 000 L splasher pool); and

$D_2$  is the density of algal food desired in the larval tank (say  $1 \times 10^4$  cells/mL).

Assume there is a culture of *Isochrysis* sp. (Tahitian) with a mean count resulting in  $1.2 \times 10^6$  cells/mL ( $D_1$ ). The larval tank volume is 4500 L ( $V_2$ ) and larvae are to be fed at an algal density of  $1.5 \times 10^4$  cells/mL ( $D_2$ ). The volume of algal culture needed ( $V_1$ ) is:

$$V_1 = (1.5 \times 10^4) (4500) / 1.2 \times 10^6 = 56.2 \text{ L}$$



**Figure 7.3** (a) Improved Neubauer Haemocytometer counting chamber for counting algal densities; (b) magnified centre grid for counting cells

A large inoculum of greenwater culture should be transferred to a new clean tank every 7 to 10 days, while still healthy, to start a new culture. About 10 to 15% starter culture is added to 85 to 90% filtered seawater, and fertiliser medium (Dix Mix) is added to the total volume of seawater (including the algae that have been added) at the rate of 1 mL/L. As the volume is increased with filtered seawater over following days, enough fertiliser should be added to compensate for the newly added filtered seawater but not for the total volume. If 500 L of greenwater is growing well it can be topped up to 1000 L (and add 500 mL of Dix Mix). However, it is better to have several 500–1000 L cultures going than a single 5000 L culture in case problems arise. Likewise, it is desirable to have several cultures going at different stages of development.

### 7.1.3 Wells–Glancy method

This method, as described in Castagna and Kraeuter (1981), has been most successfully used in temperate hatcheries. It works well for the hard shell clam, *Mercenaria mercenaria* at Wachapreague, Virginia, United States (Dr Michael Castagna's hatchery). The MMDC has used this method to feed giant clam larvae, but reports from other areas in the Pacific indicate that it does not work as well for them as in Palau. More recently MMDC has reared larvae without any feeding and claims good results, but this work has only been done on *Tridacna derasa*.

The seawater is filtered with a 25 µm GAF filter bag, and a 10 t tank is half filled three days before a planned spawning. The algae naturally present in the seawater grow, and are available as food to the giant clam larvae obtained from a spawning in another tank. No significant algal growth has been experienced with this method on the Great Barrier Reef (Lizard Island Research Station and JCUOIRS), Fiji, Philippines, or in Papua New Guinea. Thus, it is recommended to use greenwater culture instead.

### 7.1.4 Processed algal feeds

Processed algal feeds, such as Algal 161 (*Tetraselmis suecica*), are now available for bivalves. Usually, these feeds are dried cells of monocultured algae, having a shelf-life of one year. Dried algae feeds present an alternative to hatchery grown algae, and are advantageous to those facilities lacking



an algal culture unit, or the personnel required to maintain such a unit. Also, algae grown at a large algal culture facility may be concentrated into a thick paste with a cream separator and held for some time under refrigeration to use when needed.

### 7.2 Yeast

The use of yeast for giant clam larval food was first documented by Fitt et al. (1984). In his study he found the combination of yeast and vitamins to be best for larval survival and growth. The value of yeast as a food is questioned, however, as other larval researchers have not had such positive results as in the petri dish experiments of Fitt et al. (1984). Dry yeast is convenient, so it may be worth trying if there are no algal cultures. Add about 2.5 g of dry yeast to 2 L warm tap water (this will feed larvae in a 10 000 L larval tank; 0.25 g/t culture water) and vitamin B<sub>1</sub> (Thiamine HCl) at the same rate as for Dix Mix (0.372 g/t culture water), or crushed/powdered multi-vitamin tablet(s) from which the approximate amount of vitamins can be determined. Fitt et al. (1984) had good results from a combination of yeast and a vitamin mix described by McLaughlin and Zahl (1957) for the culture of zooxanthellae, but with putrescine omitted. The yeast should sit in the warm water for 20 to 30 minutes to become activated and then added to the larval tank near the aeration. If the larvae are eating the yeast it will show within the gut of the larvae examined under a compound microscope. Another yeast extract and vitamin alternative is the famous Australian 'Vegemite'. Add 1 mg/L (i.e. 10 g in a 10 000 L rearing tank).

### 7.3 Microencapsulated diets

Microencapsulation of formulated diets for penaeid prawn larvae has made larval culture of prawns somewhat simpler. Frippak Feeds (U.K.) pioneered the commercial production of these diets for prawns. Bivalve microencapsulated diets have been tested mainly on temperate species of oysters (Chu et al. 1982, 1987; Langdon and Seigfried 1984). Southgate (1988, 1990) used four types of microencapsulated diets on giant clam larvae (Figure 7.4). He found that when compared with algal-fed and controls, the microencapsulated diets had the highest survival rates of larvae to

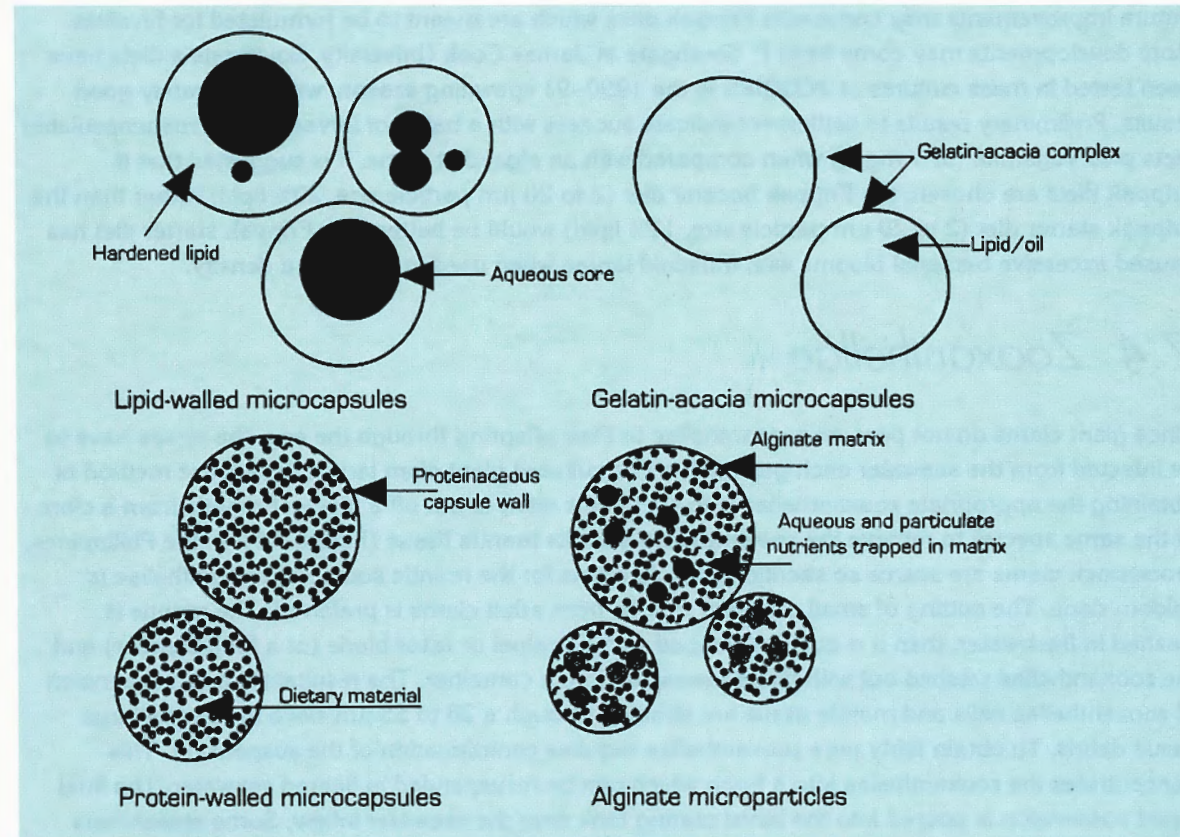


Figure 7.4 Different types of microencapsulated diets (source: based on Southgate 1988)

settlement. Likewise, survival to 35 days (metamorphosed juveniles) was almost identical for algal-fed and microencapsulated-fed treatments, though no controls survived. A successful microencapsulated artificial diet would be easy to store dry on the shelf, and could replace algal cultures. This would allow establishment of giant clam hatcheries in remote areas.

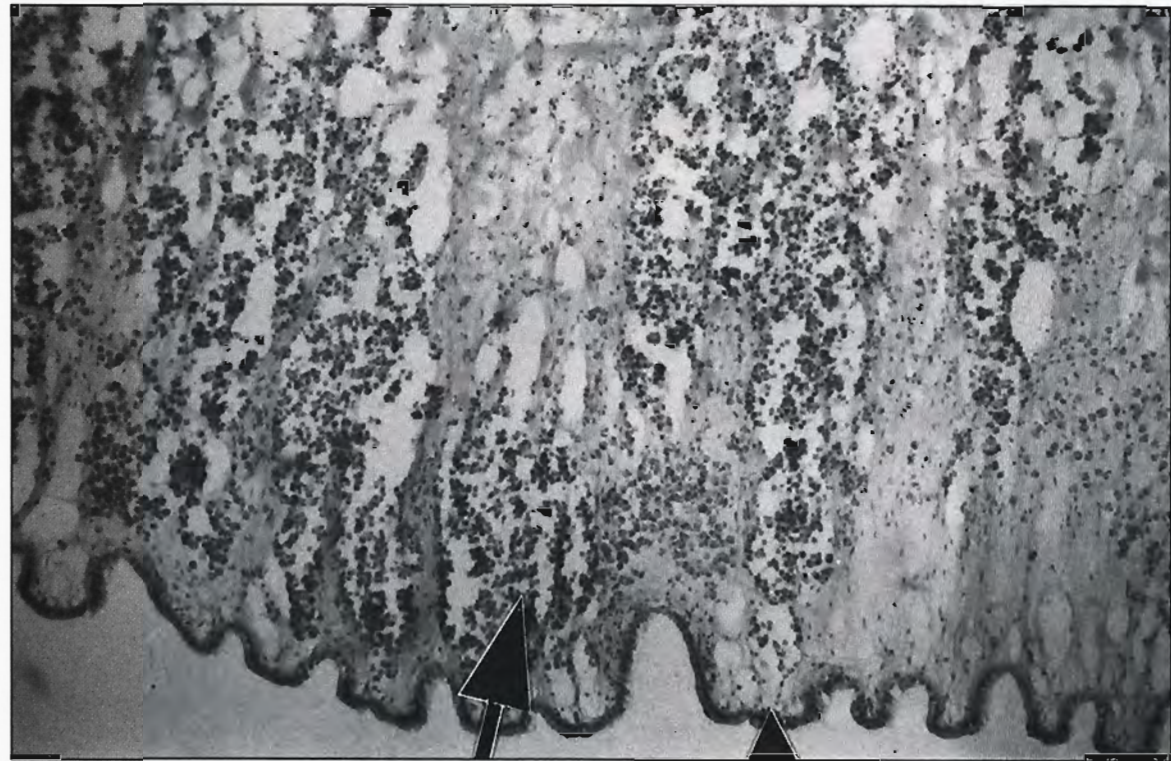
Future improvements may come with Frippak diets which are meant to be formulated for bivalves. More developments may come from P. Southgate at James Cook University. Southgate's diets have been tested in mass cultures at JCUOIRS in the 1990-91 spawning season, with moderately good results. Preliminary results to settlement indicate success with a batch of larvae fed microencapsulated diets plus Vegemite (at 1 mg/L) when compared with an algal diet alone. It is suggested that if Frippak diets are chosen, the Frippak booster diet (2 to 20  $\mu\text{m}$  particle size, 20% lipid) rather than the Frippak starter diet (2 to 20  $\mu\text{m}$  particle size, 12% lipid) would be better. The Frippak starter diet has caused excessive bacterial blooms with tridacnid larvae when used at too high a density.

### 7.4 Zooxanthellae

Since giant clams do not pass on zooxanthellae to their offspring through the egg, the larvae have to be infected from the seawater each generation. For cultured giant clam larvae the easiest method of obtaining the appropriate zooxanthellae is to sacrifice a clam or cut off a piece of mantle from a clam of the same species to retrieve the zooxanthellae from its mantle tissue (Figure 7.5). In the Philippines, broodstock clams are scarce so sacrificing whole clams for the mantle source of zooxanthellae is seldom done. The cutting of small pieces of mantle from adult clams is preferred. The mantle is washed in freshwater, then it is cut and scraped with a scalpel or razor blade (or a food blender) and the zooxanthellae washed out with filtered seawater into a container. The resultant brown suspension of zooxanthellae cells and mantle tissue are strained through a 28 to 55  $\mu\text{m}$  sieve to remove large tissue debris. To obtain fairly pure zooxanthellae requires centrifugation of the suspension. This concentrates the zooxanthellae into a lump which can be resuspended in filtered seawater. The final liquid suspension is poured into the larval rearing tank near the seawater inflow. Some researchers believe the zooxanthellae suspension should be fed to larvae when they are veligers. Start with a feed of zooxanthellae on day three post-fertilisation, and feed again on days five, seven and nine. Settled larvae or early juveniles can be observed under the microscope to determine if they have taken up the zooxanthellae which appear as golden-brown spheres in the gut or developing mantle.

A great deal of research needs to be done on this symbiont with the giant clams. A super strain of zooxanthellae may someday be developed which will improve the growth of juvenile clams. Work on

maintaining large cultures of tridacnid zooxanthellae using standard unicellular culture media is only beginning. It is possible that future clam larvae will be inoculated with cultured zooxanthellae of known prehistories. When this stage is reached it will be more possible to control both the animal and its algal symbiont. CSIRO Fisheries Division, Hobart, Tasmania (Dr Shirley Jeffrey) maintain zooxanthellae cultures from various sources, some of which include cultured tridacnid clam zooxanthellae.



**Figure 7.5** Photomicrograph of mantle tissue of tridacnid clam showing zooxanthellae in tertiary extensions of the gut. Left arrow indicates zooxanthellae, right arrow epidermis of mantle

## Larval settlement and metamorphosis to juveniles

At about five to seven days post-fertilisation the larvae should be pediveligers and the number of swimming larvae in the tank should decrease. The pediveligers settle to the bottom and the foot begins to probe about. The larvae are about 200  $\mu\text{m}$  shell length near settlement. This stage of larval transition is a very stressful time for larvae and typically large numbers die. This is not unique to giant clam larvae, as other bivalves (oysters, scallops, sand clams) in temperate hatcheries also die at settlement and metamorphosis. Giant clams are unusual, however, in that they swim for only one week, settle and then spend another 10 or so days metamorphosing into juvenile clams. Most other bivalves spend two to three weeks in the swimming phase, and settlement and metamorphosis occur within a short time. This protracted period on the bottom while developing gills, mantle, other organs, and incorporating ingested zooxanthellae cells can spell mass mortality to settled larvae if the lipid reserves are low or if conditions on the bottom are unhygienic. Recent evidence does point to the need for heterotrophy in juvenile giant clams as supplementary food to their carbon requirements (supplied by autotrophy). Investigations into juvenile-tridacnid nutrition and experiments with cheap supplementary particulate organic foods after metamorphosis are needed.

### 8.1 *Estimating the numbers of settled pediveligers in the larval culture tank and stocking them into land nursery tanks*

When larvae are grown in high density culture, the tank is drained after settlement and an estimate of live settled larvae made. All the water except the bottom 5 to 10 cm is siphoned or drained out, then the remainder of water and settled larvae on the bottom surface are drained (and washed with filtered seawater) onto a 80 to 100  $\mu\text{m}$  sieve. As explained under 'egg count estimates' (section 5.4), the settled larvae are concentrated in a container of known volume, plunge stirred, and 1 mL aliquot

samples are taken and placed on a Sedgewick Rafter Counting Chamber or a tissue culture plate with 24 cells. It is very important that the plunging be done constantly whilst the aliquot samples are being taken because settled larvae will fall rapidly to the bottom without considerable water movement, thus giving incorrect counts. Three sets of 100 larvae should be counted and the number of these 100 alive or dead for each set noted. An estimate of total live settled larvae can be made and stocked into the nursery tanks at 5/cm<sup>2</sup> bottom surface area. The volume of the nursery tank is no longer as important as the bottom surface area. It is advisable to continue using a 25 µm GAF filter bag at least for two weeks after the larvae have settled. The flow rate of filtered seawater can be increased to 8 to 10+ L/min. The higher the flow rate the better but this depends on the costs for the hatchery. In tanks which are both larval rearing tanks and continue on as nursery tanks, the same flow-rates apply.

Aeration should also be provided to the tank at several points or from a line running across the floor diameter. A simple circular airline placed about half way between the tank edge and the centre, made of 12 mm (0.5 inch) polypipe with small nail holes every 20 cm is sufficient.

Inflow of seawater may be at the surface. Drainage should be from the bottom of the standpipe by having a larger pipe sleeve (with notches cut on the bottom end) placed over the standpipe outflow (Figure 8.1). The old seawater from the bottom will be drained in this way. A good design for the inflow of seawater is to have a delivery pipe going vertically to the bottom. Holes are drilled (1.6 mm = 1/16 inch drill bit) near the bottom and up half way through the water column. These face one direction in a circular tank to begin a circular flow. Likewise, this can be accomplished with a single hole drilled into a PVC pipe end piece. If desired, a more elaborate set of four vertical pipes with two on each side of the tank centre will give a better circular flow (Figure 8.2). The holes on each set of two pipes will face opposite directions and fewer holes must be drilled into the pipes nearest the inflow.

It is important to stress the need for water currents to flow along the bottom at the level of the small juvenile clams. If this does not occur a dead layer will be created where there is virtually no mixing of new seawater. This condition combined with overgrowth from filamentous algae can prove devastating to the juvenile clams. There are problems in getting sufficient circulation on the bottom. Raceways and other rectangular tanks will have dead spaces in the corners, and a strong water flow

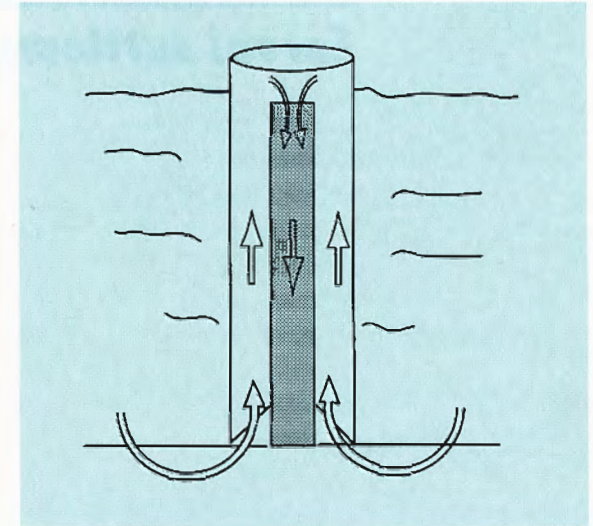


Figure 8.1 Design for drainage of seawater from larval rearing tanks

and aeration are needed along the length of the raceway or else there will be dead regions on the bottom. At UPMSI raceways with a centre wall about 1.5 m shorter in length than the raceway allow for a flow around the tank. Circular tanks are good if a circular current is generated by the water inflow as explained above. In general, aeration creates currents, but is not effective far from the source of the aeration. Figure 8.3 shows good and bad situations in tanks with regards to water currents and aeration.

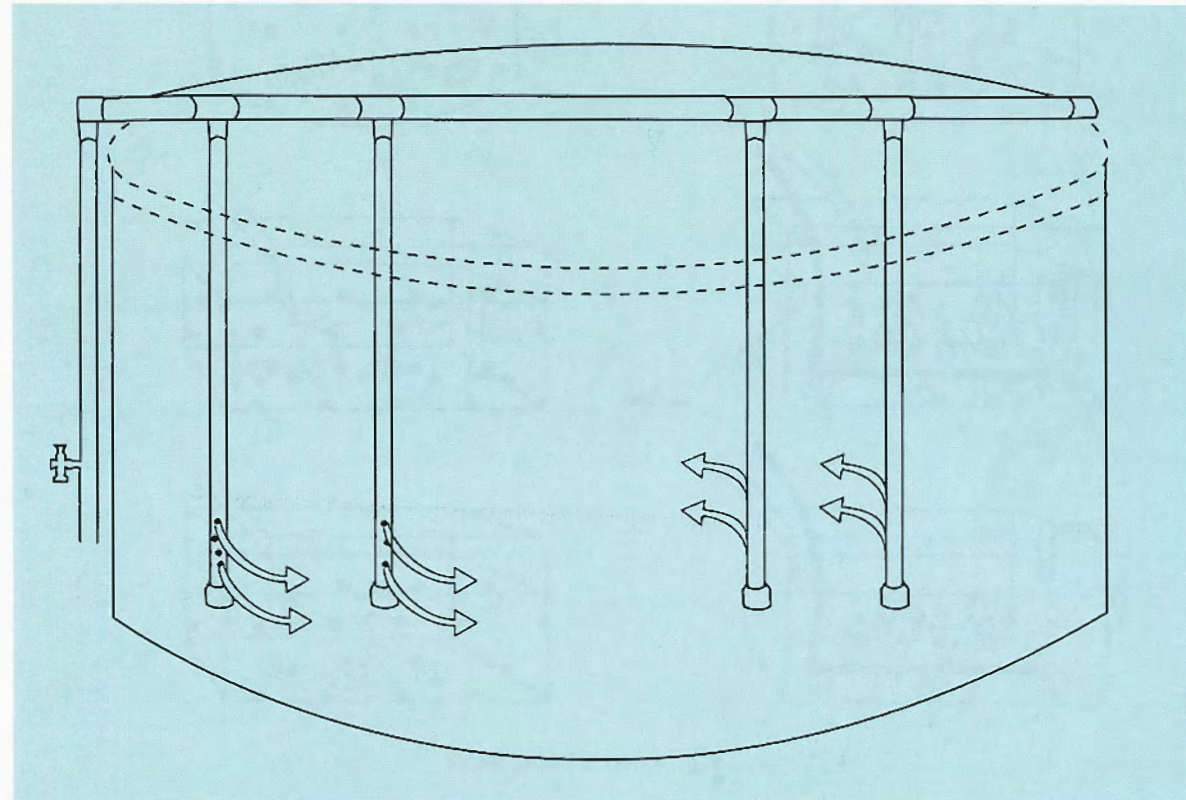


Figure 8.2 Design for inflow of seawater into larval rearing tanks

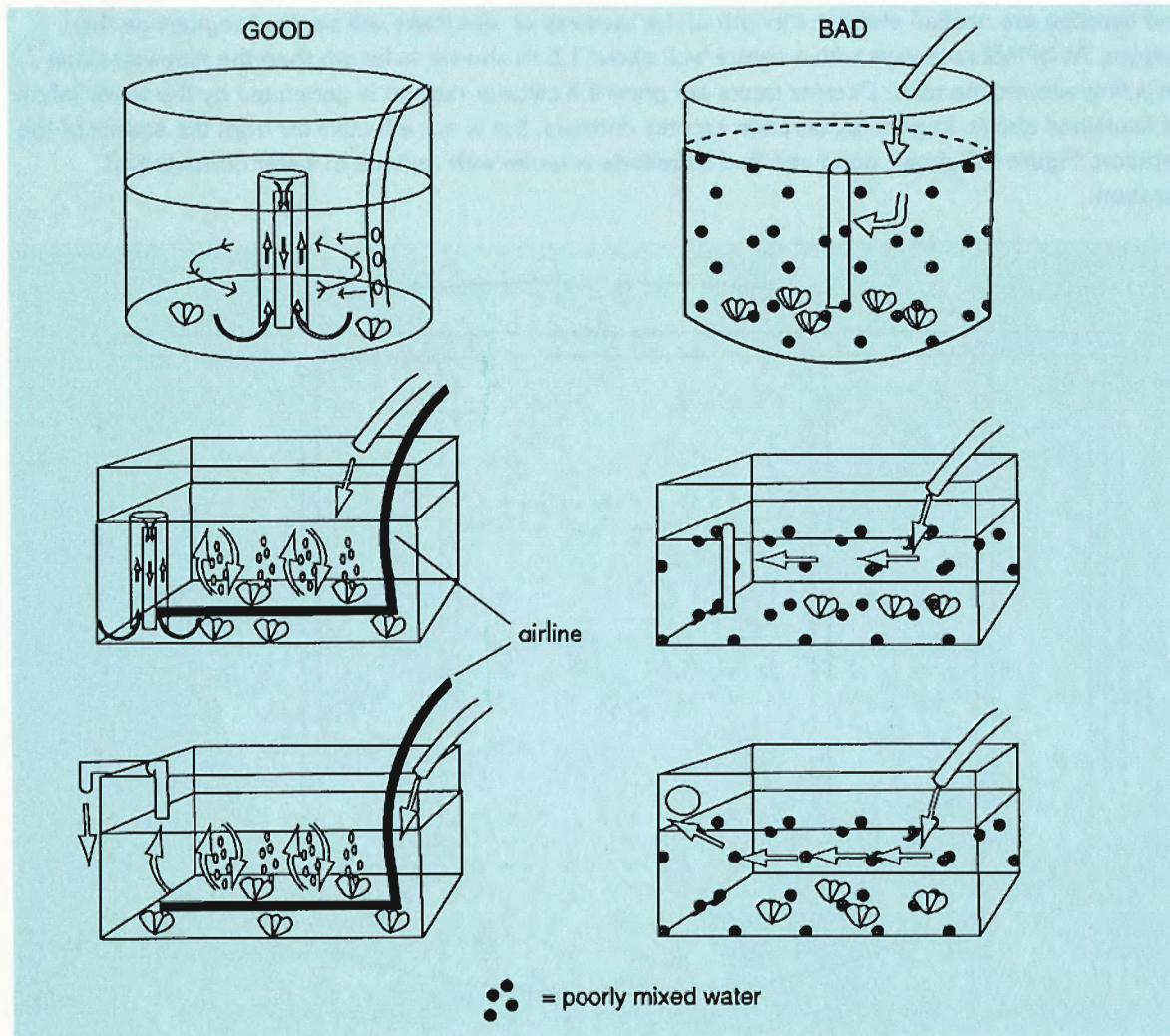


Figure 8.3 Good and bad situations in culture tanks for water currents (arrows) and aeration



## 8.2 *Sampling in nursery tank to estimate survival*

An estimate of the number of juveniles surviving can be made every few days if desired. A circular template such as a piece of PVC pipe (90 mm diameter) can be placed randomly on the bottom of the tank within reach of the edge. A small diameter (8–12 mm) clear plastic siphon hose should be used to siphon the entire bottom within the template onto a small 100  $\mu\text{m}$  sieve. The juveniles caught on the sieve screen are then washed out with a squirt bottle into a petri dish for viewing under the dissecting microscope. As time passes the samples will contain considerable filamentous algae and debris which develop on the bottom with the juveniles. This may make it difficult to see the juveniles. Generally, a swirl of the petri dish water will bring most of the 'heavier particle' juvenile clams to the centre of the petri dish for easier counting. Note the average size of juveniles and the proliferation of the zooxanthellae throughout the mantle.

## 8.3 *Zooxanthellae addition after settlement*

It may be wise to add some zooxanthellae after the clam larvae have settled because some larvae do not seem to be very efficient at picking up the zooxanthellae when they are swimming larvae. The evidence thus far is that juvenile clams which do not obtain zooxanthellae around settlement or metamorphosis do not survive for long.

Several of the ACIAR giant clam project centres make it a practice to add juvenile clams of the same species from the previous year(s) spawning to the tank immediately after the larvae have settled and the water flow-through is turned on. These older juveniles may provide additional zooxanthellae (through the faeces or other release of zooxanthellae), and although it is only speculative, they may provide chemical cues to the newly settled larvae that other clams of that species are present and it is a suitable place to settle. Also, the older, more visible juveniles can be used as indicators of culture conditions, e.g. if they become sick it is assumed the smaller juveniles will likewise be sick.

## 8.4 Use of shade cloth over tanks

The use of 50% shadescreen (Sarlon material) over the larval rearing tanks and over the nursery tanks for at least the first six to eight weeks after the spawning helps to reduce filamentous algal fouling. Clear reinforced plastic Sarlon greenhouse sheeting (50% light transmitting) is also suitable, and can be converted to a greenhouse in winter where temperatures drop below 20°C. In the Philippines, a combination of materials such as 'mosquito net' and 'fish net' are used to produce a 50% shading effect. The shadescreen is used initially over the larval rearing tanks to keep insects and flying debris out of the tank. After the larvae have settled and metamorphosed it is left over the tank to keep out debris and to cut down the amount of light which will also restrict filamentous algal growth on the bottom of the tank. Small juvenile giant clams have a very thin, translucent shell and mantle tissue so that a reduced level of light intensity (from 1000  $\mu\text{E}/\text{m}^2/\text{second}$  to 400  $\mu\text{E}/\text{m}^2/\text{second}$  due to shadescreen) does not proportionally reduce the photosynthetic rate of the clams (Fisher et al. 1985). After two months of age the clams do require more light so the shadescreen may be removed and the water level reduced. MMDC uses no shadescreen on their raceway nursery tanks but the 1 m depth of their tanks and the rapid flow rates during the daytime (thus keeping the sun from overheating the water) may be enough to keep filamentous algal growth to a minimum. In shallow tanks with slower rates of seawater flow it is recommended to use a shadescreen. Higher per cent sunblock shadescreen (70%, 90%) is detrimental to the juveniles because light is too limited (Mingoa and Shelley 1988).

## Land nursery phase

This phase in the culture of giant clams covers the period from settlement and metamorphosis to about eight to nine months of age when the juveniles can be moved out to the ocean nursery phase. When the juveniles reach an age of two months they are just becoming visible to the naked eye. Mortality can still be high at this stage, but if care is taken this will not be a major problem. The biggest problem in the land nursery phase is fouling of the tank bottom and consequent detriment to the juvenile clams. Filamentous algae which foul the tank bottom compete for nutrients needed by the clams' zooxanthellae; mask the small clams, reducing light available to them; and reduce the water currents at the level of the small clams. In the Philippines, juveniles are harvested and numbers are estimated at two months of age. They are then returned to a cleaned tank or placed in nursery tanks with substrates such as dead clam shells, coral rubble and cement blocks.

At higher latitudes in the tropics (for example Townsville at 19°S) low winter surface water temperatures can initiate serious mortality of juveniles, particularly if the juveniles originated from a late summer spawning and have not reached a large enough size. The temperature tolerance of *Tridacna gigas* is stressful at the extremes of 20°C and 34°C with poor growth occurring below 25°C. The more subtidal species (*Tridacna squamosa* and *Tridacna derasa*) may have a narrower temperature tolerance range than *Tridacna gigas*, though *Tridacna derasa* appears to do well in cooler winter water temperature, even near the tropic of Capricorn. This is a good incentive to have everything running smoothly for early summer spawning of broodstock.

### 9.1 Cleaning of algal fouling on tank bottom

The development of filamentous algae on the tank bottom needs to be curbed to maintain high survival of juveniles. Little is known of the species composition of algae which develop in seawater outdoor nursery tanks. Adjacent tanks show considerable differences in algal species or varieties

which dominate in any given tank compared to others. Somehow, conditions in tanks which appear to be equal vary enough to allow some algal assemblages to dominate in one tank but not in another, or it is due to the chance processes of initial colonisation. The use of the 50% shadescreen to curb rapid algal fouling has already been discussed. Manual cleaning or polyculture with herbivores are the only other methods suggested at present.

### 9.1.1 Manual: siphon or broom

It is not recommended to attempt to manually clean the tank bottom until juveniles are about two months old. The disturbance and probable tearing of byssal threads from juveniles which occurs with such cleaning appear to have a detrimental effect on juvenile survival. Therefore, juvenile clams should be left undisturbed as much as possible. Breaking of their byssal threads results in growth checks, which show up on their shells. After two months the tank bottom can be cleaned at regular intervals (every 7 to 14 days) by wafting the algae gently with a hand or paddle just above the bottom. If the tank is too large to reach the middle from the side, floating on the surface with a mask and snorkel will work. This should loosen some of the algae from the bottom and from the clumps of juvenile clams (note that the clumping itself may cause mortality of the juveniles in the centres of the clumps). The tank is then stirred with a paddle or arm (much easier with a circular tank) to concentrate the loose algae in the centre of the tank for subsequent siphoning out with a hose and sieve (appropriate for the size of the juveniles). The juveniles which are siphoned out with the algal debris are retrieved by placing the algal-juvenile mixture in a plastic container with high sides. Seawater is run into the container and the algae is broken up with the fingers. The container is left for about 30 to 40 seconds until the juveniles have fallen down to the bottom of the container. The floating algal debris is drained off. This procedure is repeated until the water is fairly clear and juveniles are visible on the bottom.

Brooming the bottom cleans the tank but it may be unduly hard on the juveniles (with *Tridacna gigas* it does not seem to cause undue mortality but reports from Makogai Islands, Fiji, indicate that this method causes some amount of mortality in *Tridacna squamosa* juveniles). A soft bristle push broom is used to gently sweep the bottom of the tank to loosen the majority of the algae. Older juveniles are not usually loosened by the broom as are the younger ones. Again, the tank is stirred so

the debris (and loose juveniles) concentrate in a pile which can be siphoned (and juveniles retrieved) as described above.

In the culture system developed at MMDC the young juvenile clams are placed on basalt chips in fibreglass trays so that the clams can attach to the chips and still be moved without damaging the byssal attachment (Heslinga and Fitt 1987). Biofouling by filamentous algae is admitted to being a problem in the MMDC system. Herbivores are utilised to help control the biofouling.

Some hatcheries may lack a sand-gravel filter or a sedimentation tank for removing silt and sand from the raw seawater before it enters the rearing tanks. Unless a filtering apparatus is installed directly onto the rearing tank inflow water, incoming seawater may be laden with silt that tends to settle and cake at the bottom of the tank. This layer of silt is removed by scraping the bottom with a small knife, simultaneously siphoning the scraped material. This is best done while snorkeling in the tank where the water level is reduced to allow reaching the tank bottom. Care is taken that the attached juveniles are not disturbed.

### 9.1.2 Herbivore polyculture

The ideal means of cleaning algal fouling from on and around juvenile clams is to have a herbivore being cultured in the tank with the clams which purposely eats only algae and will avoid the clams. The difficulty is in finding an animal which will grow with the clams so that it is very small and does not damage the clams while they are still microscopic. Heslinga et al. (1984) first described the use of *Trochus niloticus* in polyculture with giant clams to reduce the algal fouling. This species and other smaller trochid species substantially reduce algal fouling when they are at least 2 cm shell base diameter, but at this size their radular teeth, which scrape the substrate for their algal dinners, also easily remove (and may crush) juvenile clams less than 10 weeks of age. Large trochus leave considerable amounts of faeces in the nursery tanks and this has to be siphoned out as regularly as algae would. Nevertheless, trochus are quite easy to spawn since they tend to reproduce around the new moon. Adults can be collected from the reef three to four days before a new moon night and left in a tank. Spawning typically begins around 1900–2000 hours and may continue for a couple of hours. The eggs are greenish coloured, with a pitted gel layer (chorion) outside the ovum. Fertilised

eggs can be held in hatching tanks with antibiotic with good results. The hatched larvae swim for only two to three days without need for feeding and settle best on a substrate with coralline algae. Growth is not rapid so that batches of trochus should be produced some months before a planned spawning of giant clams. The juvenile trochus should not be used until the clam juveniles are 10 weeks old.

Several fish species have been suggested as suitable polyculture organisms with giant clams. Siganids (rabbitfish), parrotfish and surgeonfish may all be suitable for reducing algal fouling as long as the fish are juveniles and not seen to pick at clam juveniles. They should be tested in small aquaria with some juvenile clams of the appropriate size before being added to the nursery tanks. These fish would have to be caught by a throw net or other means. The euryhaline (tolerant to a wide range of salinities) black mollie, a livebearer, may be adapted to living and breeding in full salinity seawater. They feed on the fouling algae but a large breeding stock would have to be realised to produce enough offspring to effectively clean the algal fouling in a giant clam nursery tank. In Tonga, Mexican mollies are being used to clear fouling algae in the giant clam nursery raceways.

A molluscan herbivore, *Stylocheillus* sp., which appears in many hatchery tanks throughout the tropics is a relative of the seahare. Unlike trochus, this shell-less mollusc grows very quickly and if relatively small juveniles are kept in the nursery tank they may help reduce algae for juvenile clams younger than 2 months. However, they grow quickly, produce a lot of faeces, and it is difficult to see even quite large ones because of their algal-like camouflage. Unculled large *Stylocheillus* would kill a lot of juvenile clams with their substantial radular scraping teeth. A gastropod herbivore which is common amongst rocks on the muddy reef flats of north Queensland, is a black cerithid snail. This snail has appeared in tanks at Orpheus Island, appears to reproduce well in a flow-through tank system, probably by direct development of the larvae to settled juveniles. These cerithid snails do a good job of containing filamentous algal fouling in the juvenile clam tanks.

Amphipods were used first at Reefarm Pty Ltd (North Queensland) to keep fouling algae clear on the tank bottom where it is near to their nests. Since amphipods are omnivores, it would be wise to add them to a nursery tank after juvenile clams are at least 10 weeks old. The JCUOIRS have used amphipods with success in controlling filamentous algal fouling.

In the Philippines, herbivorous hermit crabs (without enlarged chelipeds) have also been useful in the control of algal overgrowth. They are such good grazers, however, that they may have to be removed after a brief period of grazing, or when all the algae are removed. Otherwise, they starve and die, or may prove to be harmful to the clams.

## 9.2 Seawater

### 9.2.1 Flow rates and aeration

The flow rate of seawater will depend on the size of the nursery tank. Large tanks should be turned over at least once per day, preferably twice. A single 24-hour turnover in a 10 t tank would require 7 L/min flow rate. If the water level of the tank is dropped, a greater turnover rate will be achieved with the same inflow rate. This is one reason for keeping the nursery tanks shallow. MMDC in Palau runs 20 to 25 L/min for 12 hours/day into 8 to 10 t tanks (Heslinga et al. 1984); this amounts to about two changes per day. The more seawater pumped through the tank the greater the nutrients which are available to the juvenile clams for their growth and zooxanthellae maintenance. The economics of running the pumps has to be considered, as well as the advantages and disadvantages of artificial nutrient addition.

### 9.2.2 Filtered or unfiltered seawater

The use of bag-filtered seawater to fill the larval rearing tank is prudent in order to keep out predatory zooplankton. Retention of the filter bag thereafter depends on plans for that batch of juveniles. If the juveniles are planned for future international export they will have to be kept in at least 1  $\mu\text{m}$  bag-filtered seawater. If the juveniles are planned for experiments for which contamination by potential parasites or commensal invertebrates is to be avoided before use, the filter bags will have to be kept on. It is wise to leave filter bags (even if only 25  $\mu\text{m}$ ) on nursery tank inflows until metamorphosis is complete (20 to 30 days post spawning).

Unfiltered seawater will carry more organic material with it, and adhering to this may be more nitrates and phosphates than merely the dissolved form of these nutrients which pass through filter bags.

Thus, unfiltered seawater should be superior to filtered seawater for the growth of juvenile clams, especially after the juveniles reach a size that is safer from filamentous algal overgrowth.

### 9.3 Nutrient addition

High densities of juvenile giant clams in nursery tanks with benthic algae leave the tank water in a nutrient-limiting situation for growth of the juveniles. Trials with nutrient addition have indicated that growth is substantially improved with the use of nutrients (Fitt et al. 1984; Solis et al. 1988; Heslinga 1988; Braley et al. In press). It appears that nitrogen as ammonium sulfate (or ammonium chloride) is taken up more readily than nitrogen as a nitrate. Phosphorus as a phosphate (in superphosphate, for example) is also taken up but the exact ratio of nitrogen to phosphorus for optimum growth in juvenile clams has yet to be tested. In an experiment run at JCUOIRS from late July to mid-October 1989, ammonium chloride dosages of 20  $\mu\text{g}$  and 40  $\mu\text{g}$  were given daily to flow-through tanks and every other day to recirculating system tanks. A superphosphate dosage of 2.3  $\mu\text{g}$  was given once per week to all treatment tanks. Growth of both 7 months and 3.5 year juvenile *Tridacna gigas* was considerably better than controls, but there was a smaller difference in growth rate between dosages of the ammonium chloride. Further results from nutrient addition on growth of giant clams will undoubtedly come from all giant clam facilities. Heslinga et al. (1990) present a good account of the MMDC's use of nitrogen enrichment (ammonium nitrate) in their land nursery system. As of 1991, virtually all giant clam facilities were using some nutrient addition in their land nursery systems, though the nitrogen compound may be different.

It should be noted that nitrogen addition will promote algal growth in the tank. When feeding nitrogen or phosphate it is advisable to feed in daylight because these nutrients are depleted during the day within the clam. Some facilities still consider it more important to feed in late afternoon or early evening when nutrients will not be able to be utilised directly in photosynthesis by fouling algae in the tank. However, it may be that the fouling algae can store the nutrients overnight, as do the clams, for use during daylight.



## 9.4 Greenhouse heating in combination with recirculating system

In those higher latitude areas within the tropics which experience a drop in seawater temperature to 21°C or lower during winter months, it is possible to maintain summer seawater temperatures (27–30°C) with direct solar heating in a greenhouse enclosing the tanks, and biological filters. The seawater in a closed recirculating system passes through biological gravel or algal filters to remove the organic wastes and returns the seawater in somewhat of a purified state to the tank. This was tested successfully at JCUOIRS in winter 1989 (Braley et al., in press). A cheap 50% solar transmitting reinforced plastic sheeting (Solar-Gro, made by Sarlon) was fabricated to fit over a metal pipe canopy over 3 tonne circular fibreglass tanks (Figures 9.1 and 9.2).



Figure 9.1 Greenhouse enclosure using 50% solar transmitting reinforced plastic material, JCUOIRS

The greenhouse also enclosed coral rubble trickle filters and associated algal scrubber trays. Although the mean daily minimum air temperature for the coldest week outside the greenhouse was 15.6°C, the mean minimum air temperature inside the greenhouse was 20.0°C and the tank water temperature was 24.8°C minimum and 29.8°C maximum. Even in flow-through seawater tanks within the greenhouse, growth of juvenile clams was found to be much better than clams in outside ambient temperatures, though the difference in water temperatures was often only little more than 1–1.5°C.

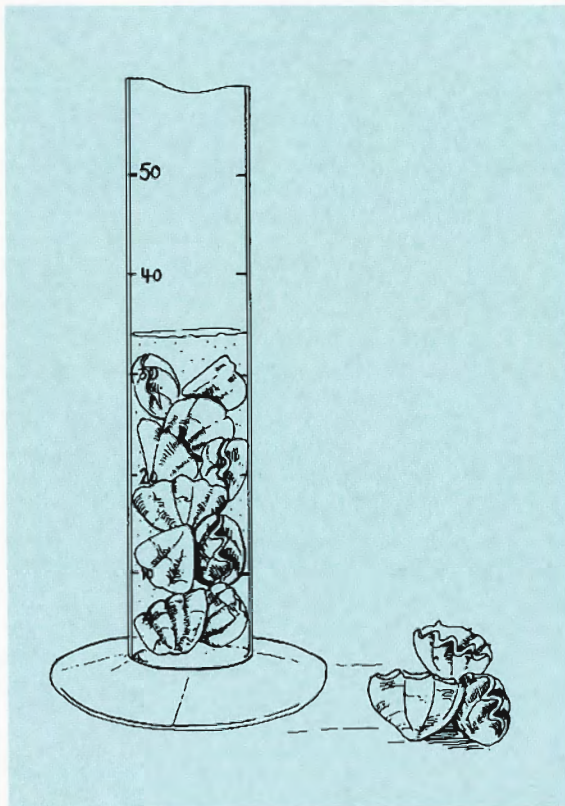
The winter mortality problem of juvenile clams from late summer spawnings can be circumvented with the use of a greenhouse over the nursery tanks, preferably in conjunction with nutrient addition. Adult *Tridacna gigas* and *Hippopus hippopus* have been held in a greenhouse recirculating seawater system with nutrient addition over winter 1990. The result of this conditioning is generally positive on the reproduction and egg production of the clams, especially *Hippopus hippopus*.

### 9.5 Volumetric count estimate from land nursery phase before transfer

Juvenile clams are collected from the land nursery tanks by cutting the byssal attachments with a knife. A sharp kitchen knife or sharpened butter knife may be used to scrape 10 cm wide areas of the tank bottom, thus loosening the juvenile clams. The clams are then siphoned out of the tank onto an appropriate size screen. The clams are placed in a tray and a piece of flexible plastic is used to take a random portion of the pile of clams (to randomly include large and small individuals) for counting. Five to ten groups of 100 individuals are counted out. These seed clams are blotted dry on a towel. A small amount of seawater is added to a graduated cylinder and volume noted. A group of 100 clams are added to the cylinder and the increase in the water volume in the graduated cylinder of each group of 100 clams is recorded (Figure 9.3). The average volume per 100 individuals is used to determine the number of clams in the total volume from that tank. Clams destined for various protective containers in the ocean nursery are then removed by volume for those containers.



Figure 9.2 Clams in tank covered by 50% solar transmitting reinforced plastic material, JCUOIRS



**Figure 9.3** Volumetric measurement of juvenile clams to estimate total number before moving to ocean nursery

#### Box 9.1

*Example of calculations for estimating volume of clams for ocean nursery tank*

Assume 5.2 mL sea water displaced per 100 clams added (average), then 52 mL = 1000 clams.

If 3500 clams per ocean nursery container are required, then  $52 \times 3.5 = 182$  mL of sea water must be displaced.

A known volume of sea water (say 20 mL) and clams are added until the filtered seawater volume reaches 202 mL.

A simpler volumetric measurement that is almost as accurate is to place the clams directly into the graduated cylinder and fill water to the top level of the clams to read the volume.

Estimation by volume can be checked with an estimation by weight (Castagna and Kraeuter 1981). Here, the groups of 100 clams are put in a tared (pre-weighted and set to zero on the balance) plastic container; the group of 100 clams is submerged in seawater, drained for a set time (30–45 seconds) and weighed. The balance should be accurate to 0.01 gram. The average weight is determined per 100 clams and the total clams are weighed to estimate total numbers.

---

## **Genetics in culture**

Detailed discussions of breeding and genetics are beyond the scope of this manual, but it should be noted that there are consequences of breeding large numbers of young from a small number of broodstock. This can have an important influence on the viability and productivity of the batches produced. There are further implications for batches produced to restock natural populations as opposed to farm production where most of the young will be harvested for food.

Genetic analysis of clam batches produced by hatcheries has demonstrated that the batches show reduced genetic variability compared with natural populations. Hatchery batches also differ greatly in genetic makeup from the natural populations from which their parents were derived, and differ greatly from batch to batch. This is a consequence of the small number of adults used to produce a batch.

The implications for hatchery management are that a single batch produced by two parent clams is unlikely to be representative of a natural population. If a batch is to be produced to restock natural reefs it is better to use several adults to produce a batch, and far better to use several batches produced by different sets of parents. Such a practice does not guarantee the product will be the same as the natural stock, but it does increase the chance it will be so, and reduce the risk that genetic variation is lost.

Giant clams in different regions of the Pacific are quite different genetically. Once again, the implications for hatchery producers are that programs to restock natural populations might best use local animals if these are available, and that imported clams will not necessarily have the same genetic constitution. This is an important element in work towards the re-establishment and conservation of the resources upon which giant clam producers ultimately depend.

The constraints on batches produced for food are less, but where some animals might be used as future broodstock they are similar. However, there is some indication that animals which are more

genetically variable (more heterozygous) have better growth rates than those which are less diverse and there is therefore some relevance to batches produced simply for meat. Records should be kept of the parents used to produce these batches. First, to establish which parents have produced good batches, and second, to avoid inbreeding if offspring produced by the hatchery are eventually used as broodstock. If all the batches had one parent in common, the rate of inbreeding using such a system would be high, and there are many examples in agriculture of the loss in viability and productivity resulting from inbreeding.

Full scale breeding programs are beyond the capability of most hatcheries. Nevertheless, care taken to rotate the parents used in producing different batches, and using several parents to produce each batch where possible, will be a useful strategy to reduce loss of variation and provide greater confidence that if hatchery produced broodstock are used, they will be reliable. The alternative of using only one or two of the apparently best performing animals alone to produce all future broodstock, is a recipe for eventual disaster.

Advice on access to further information on genetics and breeding can be obtained through local government agencies and international organisations.

## Diseases, parasites and pests

While there is a large body of literature on diseases of molluscs, there is little information on the diseases, pathogens and parasites of the clams (Gibbons and Blogoslawski 1989) in general and of the giant clams, *Tridacna* and *Hippopus* species in particular (Humphrey 1988; Anderson 1990). This is probably related to the relatively recent cultivation of the giant clams compared to other molluscs.

The giant clam is known to be infected by *Perkinsus* species and *Martella* species, both of which are serious pathogens in other cultured molluscs (Luckner 1983). To date, no virus, chlamydia, mycoplasma, fungus or neoplasm has been reported in giant clams. The large majority of the deaths in cultured juvenile and adult giant clams has been associated with adverse environmental factors rather than specific infectious pathogens.

In order to minimise the risk of spreading disease, parasites or pests, it is important to take steps to quarantine clams both in exporting and importing countries. In the early 1990s there were reports of *Tridacna derasa* being introduced to the Caribbean Ocean. Such trans-ocean introductions are not to be condemned. No living tridacnid clams are found in the Caribbean or Atlantic Ocean, thus a new family of bivalve mollusc is being added.

The translocation of zooxanthellae with the clam shipments is another consideration. Perhaps in future, all the clam translocations will be made by sending complete larval (settling pediveligers) which have not yet been infected with zooxanthellae. The zooxanthellae will then be obtained from clams in the importing country and given to the clam larval on arrival. Another option would be to culture zooxanthellae and offer only the cultured symbiont to the clam larval.

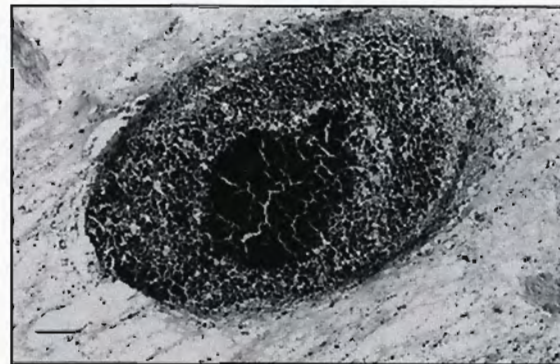
This chapter provides details of known infections, pathogens, parasites and diseases in Tridacnidae. Details of quarantine protocol for the export and import of giant clams are given in Chapters 12 and 13.

**Bacterial disease or necrosis of larvae and young juvenile clams (< two months old)**

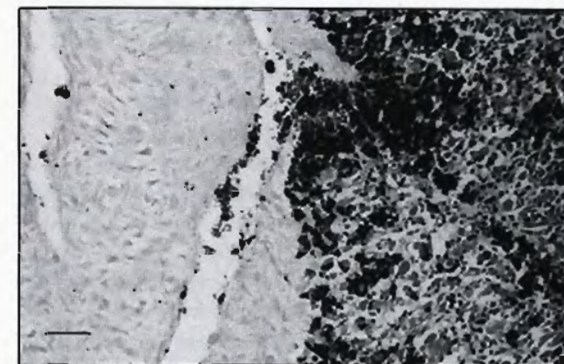
|                                 |   |                                 |   |  |
|---------------------------------|---|---------------------------------|---|--|
| <b>Species affected:</b>        | <i>Tridacna gigas</i> (probably all species).   | <b>Predisposing conditions:</b> | <ul style="list-style-type: none"> <li>• Heavily contaminated culture facilities.</li> <li>• Algal cultures heavily contaminated with bacteria.</li> <li>• Poor culture tank hygiene.</li> <li>• High nutrient levels in water of the culture tank.</li> <li>• Dead clams in the culture system.</li> </ul>   | <ul style="list-style-type: none"> <li>• Maintain a very low nutrient level in culture water for juvenile clams younger than 3 months of age.</li> </ul> |
| <b>Geographic distribution:</b> | Wherever giant clams are cultured.  |                                 |   |  |
| <b>Cause:</b>                   | Bacteria, especially <i>Vibrio</i> species; also <i>Aeromonas/Plesiomonas</i> species.  |                                 |   | <b>Further reading:</b> Gibbons and Blogoslawski (1989), Sindermann (1988), Sutton and Muir (1990).  |
| <b>Gross signs:</b>             | Rapid death of clams, within 48 hours.  | <b>Effect on host:</b>          | Necrosis and death, usually of the whole batch within 24 to 48 hours.   |  |
| <b>Histopathology:</b>          | Large numbers of bacteria, usually gram-negative, associated with necrosis of clam tissues.   | <b>Treatment:</b>               | None; the mortality is too rapid for an antibiotic to work.   |  |
| <b>Bacteriology:</b>            | Cultures for <i>Vibrio</i> species, etc.  | <b>Prevention:</b>              | <ul style="list-style-type: none"> <li>• Use a batch system with thorough cleaning, disinfection, rinsing and drying prior to use.</li> <li>• Use bacteria-free (axenic) algal cultures.</li> <li>• Maintain a high standard of tank hygiene e.g. change water regularly, remove sediment, waste food, etc.</li> <li>• Maintain tank homeostasis, e.g. temperature, salinity.</li> <li>• Avoid stress e.g. excess aeration, excess water current, provide suitable substrate for byssal attachment, etc.</li> </ul> |  |
| <b>Method of diagnosis:</b>     | <ul style="list-style-type: none"> <li>• Sub-gross examination for swarming bacteria from clam tissues.</li> <li>• Bacterial culture.</li> <li>• Histopathology of sick or dying clams (preserved in 3% sea water formalin).</li> </ul> |                                 |   |  |
| <b>Life history:</b>            | <i>Vibrio</i> spp. and other marine bacteria are common in the marine environment.  |                                 |   |  |

**Bacterial disease of juvenile and adult clams**

|                                 |  |                                 |                                      |
|---------------------------------|--|---------------------------------|--------------------------------------|
| <b>Species affected:</b>        | Probably all species.  | <b>Predisposing conditions:</b> | Environmental and managerial stress. |
| <b>Geographic distribution:</b> | Wherever clams are cultured.   | <b>Effect on host:</b>          | Leads to death.                      |
| <b>Cause:</b>                   | Bacteria (gram negative) probably <i>Vibrio</i> spp.   | <b>Treatment:</b>               | None.                                |
| <b>Gross signs:</b>             | Retracted mantle; death. Yellow patches may sometimes be seen in tissues.  | <b>Prevention:</b>              | Minimise stress.                     |
| <b>Histopathology:</b>          | Abscesses containing central area of necrotic cells and bacterial colonies surrounded by a zone of granulocytes and fibrous tissue (Figures 11.1 and 11.2).            |                                 |                                      |
| <b>Bacteriology:</b>            | Culture of the heart haemolymph. In normal clams, haemolymph should be sterile.  |                                 |                                      |
| <b>Method of diagnosis:</b>     | <ul style="list-style-type: none"> <li>• History of stress.</li> <li>• Gross signs.</li> <li>• Histopathology.</li> <li>• Bacteriology of heart haemolymph.</li> </ul> |                                 |                                      |
| <b>Life history:</b>            | <i>Vibrio</i> spp. bacteria are widely distributed in the marine environment.  |                                 |                                      |



**Figure 11.1** Bacterial abscess in the mantle of a dying *Hippopus hippopus* (H & E stain, shell length 30 cm) (bar is 160  $\mu$ m)



**Figure 11.2** Bacterial infection and necrosis of the adductor muscle of *Hippopus hippopus* (H & E stain, shell length 1.4 cm) (bar is 45  $\mu$ m)



**Rickettsial infection**

**Species affected:** *Tridacna crocea*, *Hippopus hippopus*, *Tridacna squamosa*, *Tridacna tevoroa* and *Tridacna derasa*: probably all species are susceptible.

**Geographic distribution:** Great Barrier Reef, Australia; Philippines; Fiji; Tonga.

**Cause:** Rickettsiales-like organism.

**Histopathology:** Basophilic intracellular inclusion bodies are present within the epithelial cells mainly of the ctenidia (Figure 11.3) but also of other epithelial surfaces, e.g. the lateral mantle. Infected cells are hypertrophic and have a peripheral nucleus. The intracellular inclusions contain gram-negative rod-shaped structures. Usually there is a lack of host response to these inclusions. However, in young juvenile clams, a granulocytic inflammation may be associated with a small percentage of these intracellular bodies (Figure 11.4).

**Electronmicroscopy:** Prokaryotic organisms of relatively uniform appearance can be seen within the large inclusion bodies (Figure 11.5). They have a double membrane. The centre of each organism is less electron dense than the margin.

**Method of diagnosis:**

- Microscopy of wet mounts of gills for the presence of spherical cream-coloured cysts.
- Histopathology.
- Transmission electronmicroscopy to differentiate rickettsia from chlamydia which may appear histologically similar (Figure 11.5).

**Life history:** Unknown.

**Predisposing conditions:** Restricted water circulation.

**Effect on host:** Deaths if heavy infestations.

**Treatment:** None.

**Prevention:** Open water circulation in the sea.

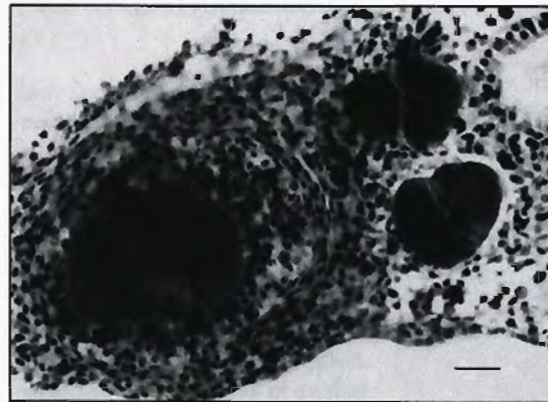
**Other comments:** A heavy infection in young juvenile *Hippopus hippopus* prevented the translocation of a batch of clams from one hatchery. Rickettsiales-like infections appear to be widespread in marine bivalves, particularly in the digestive and branchial epithelium (Elston and Peacock 1984). Although they are not usually associated with host mortality, Gulka et al. (1983) reported mortality in *Placopecten magellanicus* associated with a rickettsia-like infection in the gills.

**Further reading:** Goggin and Lester (1990); Harshbarger et al. (1977).

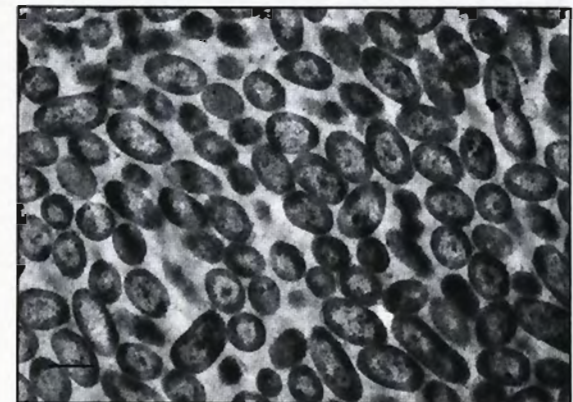
## Rickettsial infection - cont'd



**Figure 11.3** The ctenidia of a juvenile *Hippopus hippopus* with a heavy infection of rickettsia-like inclusion bodies (H & E stain, shell length 0.6 cm) (bar is 34  $\mu$ m)



**Figure 11.4** A heavy infiltration of granulocytes around a rickettsia-like inclusion body in a juvenile *Hippopus hippopus* (H & E stain, shell length 0.6 cm) (bar is 17  $\mu$ m)



**Figure 11.5** A transmission electronmicrograph of rickettsia-like organisms in the ctenidia of a *Hippopus hippopus* (shell length 30 cm) (bar is 1  $\mu$ m)

**Perkinsus infection**

**Species affected:** *Tridacna gigas*, *Tridacna maxima*, *Tridacna crocea*, *Tridacna squamosa* and *Hippopus hippopus*.

**Geographic distribution:** Great Barrier Reef, Australia; Fiji; Philippines.

**Cause:** *Perkinsus* species (at least two species suspected).

**Gross signs:** None reported to date.

**Histopathology:** The trophozoites of *Perkinsus* species appear as signet rings with an eccentric nucleus and a large vacuole. They are frequently surrounded by a halo of amorphous, eosinophilic material. They appear to be extracellular and are commonly found in the macrophage centres of the digestive organ (Figures 11.6 and 11.7) between the digestive diverticulæ.

***Perkinsus* culture:** The whole clam (if small) or parts of the digestive gland, mantle and gill are incubated at 23–30°C for 4–7 days in 15–20 ml of fluid thioglycollate medium (FTM) to

promote the development of *Perkinsus* species prezoosporangia. The medium is supplemented with 200 mg chloromycetin and 200 units of mycostain per mL to limit bacterial and fungal growth (Ray 1966).

After culture in FTM, the tissue is removed, stained with Lugol's iodine and examined under a dissecting microscope; prezoosporangia were visible as blue-black spheres (Figures 11.8 and 11.9).

*Perkinsus* sp. infection is confirmed by observation of endosporulation and of discharge tube formation in the prezoosporangium. The cultured tissue, which has not been exposed to iodine, is transferred to seawater in a petri dish to obtain live zoospores. The tissue is teased apart and the liberated trophozoites and prezoosporangia adhere to the petri dish; the seawater is decanted and fresh sea water added daily.

**Method of diagnosis:**

- Culture of the organ tissue of the clam, especially the digestive

organ, in fluid thioglycollate medium (Ray 1966) for the detection of light infections and for the definitive confirmation of this disease.

- Histopathology of preserved tissues for moderate to heavy infections.

**Life history:**

Young trophozoites in the clam's tissues multiply to yield sporangia in a mother cell or schizont which ruptures to release immature trophozoites. Under anaerobic conditions in the tissues of a dead clam, the trophozoites swell to form prezoosporangia. On return to aerobic seawater, the prezoosporangium (now called a sporangium) develops a discharge tube and undergoes internal divisions of the protoplast to produce large numbers of zoospores. These infective zoospores are released via the discharge tube and can penetrate the epithelium of the tissues of the clam. The common route is via the digestive system. All stages of the life cycle of *Perkinsus* except the prezoosporangium can initiate an infection.

**Perkinsus infection – cont'd**

**Predisposing conditions:** Unknown in clams. Stress in other molluscs e.g. high temperature, sluggish water movement, crowded conditions, etc.

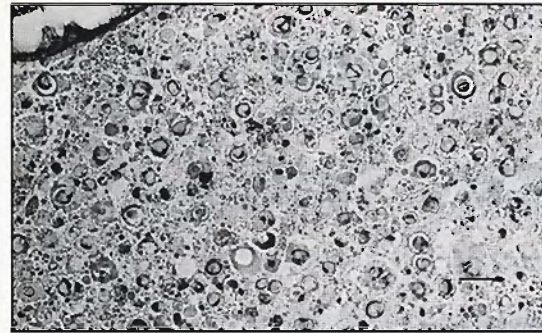
**Effect on host:** Undetermined; *Perkinsus* species has been cultured and seen histologically in both normal and dying clams.

**Treatment:** None available.

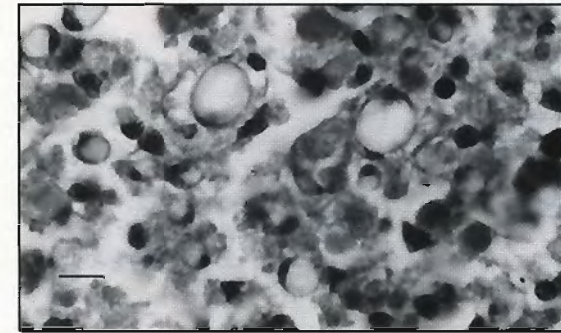
**Prevention:** Unknown.

**Other comments:** The significance of *Perkinsus* species in giant clams remains to be determined. However, *Perkinsus* species have been associated with extensive mortalities in commercially important molluscs (Luckner 1983).

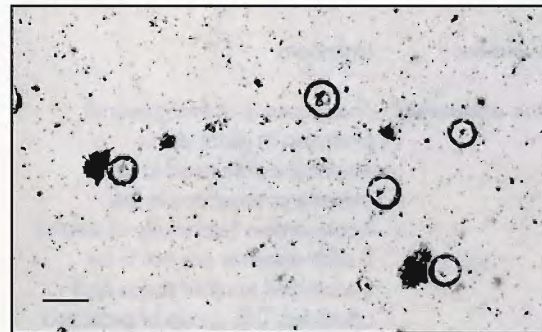
**Further reading:** Goggin and Lester (1987).



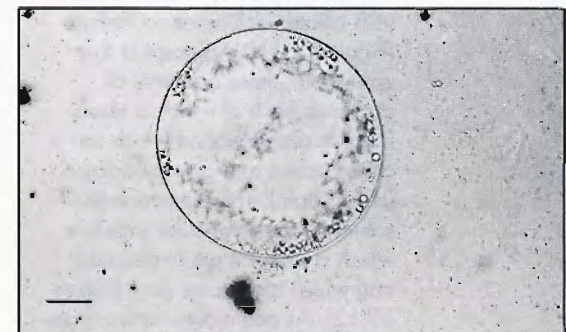
**Figure 11.6** Trophozoites of *Perkinsus* species in the connective tissue and macrophage centres of the digestive organ of *Tridacna squamosa* from Fiji (Toluidine Blue stain, shell length 22 cm) (bar length is 15  $\mu$ m)



**Figure 11.7** *Perkinsus* species organisms in the connective tissue and macrophage centres of *Tridacna crocea* from the Great Barrier Reef, Australia (H & E stain, shell length 10 cm) (bar length is 6  $\mu$ m)



**Figure 11.8** Prezoosporangia of *Perkinsus* species after culture in fluid thioglycollate medium for several days (wet, unstained preparation) (bar length is 86  $\mu$ m)



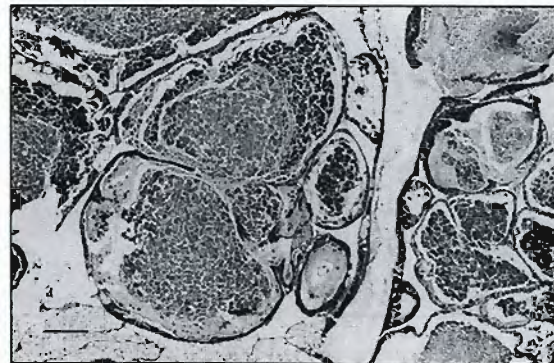
**Figure 11.9** Prezoosporangium of *Perkinsus* species as seen in Figure 11.8 (wet, unstained preparation) (bar length is 13  $\mu$ m)

**Marteilia-like disease**

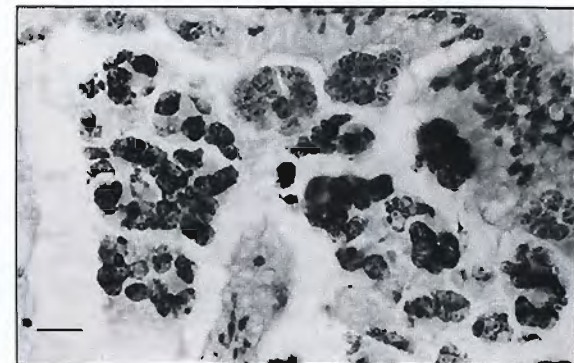
|                                 |  |  |  |
|---------------------------------|--|--|--|
| <b>Species affected:</b>        | <i>Tridacna maxima</i> .   | refracted bodies. These appear to be degenerate forms of the protozoa. | <b>Further reading:</b> Balouet (1979).  |
| <b>Geographic distribution:</b> | Fiji.  |  |  |
| <b>Cause:</b>                   | A paramyxean protozoan probably a <i>Marteilia</i> sp. or a <i>Paramarteilia</i> sp. (F.O. Perkins, pers. comm. 1990).   | <b>Methods of diagnosis:</b>   | <ul style="list-style-type: none"> <li>• Gross signs.</li> <li>• Histopathology.</li> </ul>  |
| <b>Gross signs:</b>             | Live clam — none.<br>Necropsy — numerous white splotches throughout the kidney (Figure 11.10).   | <b>Life history:</b>   | Unknown.   |
| <b>Histopathology:</b>          | The kidney lesions consist of numerous cyst-like structures lined with ciliated columnar epithelium (Figure 11.11). Adjacent to this epithelium, there are nests of protozoa each of which is about 2 µm in diameter and which has a dark nucleus and grey cytoplasm (H & E stain). They are enclosed within a larger capsular structure which is about 4 µm in diameter and which also stains grey (Figure 11.12). As one moves further from the epithelial lining, these protozoan cells assume an eosinophilic colour, lose their clear outlines and contain irregular, | <b>Predisposing conditions:</b>  | Unknown.   |
|                                 |  | <b>Effect on host:</b>   | Undetermined; a majority of the kidney had been displaced by this protozoan parasite.  |
|                                 |  | <b>Treatment:</b>  | None.  |
|                                 |  | <b>Prevention:</b>   | Unknown.   |
|                                 |  | <b>Other comments:</b>   | The presence of this group of protozoa in giant clams emphasises the need to take extreme precautions in the translocation (especially of adults) if such diseases are not to be transmitted to other areas and countries. This group of protozoa has caused extensive losses in other molluscs (Wolf 1979; Luckner 1983; Roubal et al. 1989). |

*Marteilia*-like disease - cont'd

**Figure 11.10** Lateral view of *Tridacna maxima* from Fiji showing the white kidney lesions caused by a *Marteilia*-like protozoan (shell length 18 cm) (bar is 9 mm)



**Figure 11.11** The kidney of *Tridacna maxima* showing the cyst-like structures enclosing the *Marteilia*-like protozoa (H & E stain, shell length 18 cm) (bar is 214  $\mu$ m)



**Figure 11.12** Section of kidney showing the cyst-like structure (top right hand corner) enclosing clusters of the *Marteilia*-like protozoa (H & E stain, shell length 18 cm) (bar is 14  $\mu$ m)

**Winter mortality**

**Species affected:** Young juvenile *Tridacna gigas* clams.

**Geographic distribution:** Wherever clams are cultured and the temperature drops below 20°C.

**Cause:** Chilling (hypothermia) with secondary infection by an unidentified organism.

**Gross signs:** Death in large numbers.

**Histopathology:** Banana-shaped bodies (Figure 11.13) are seen in focal areas of the epithelium of the mantle, usually the siphonal mantle, and occasionally in focal areas of the epithelium of the ctenidia of surviving clams. A granulocytic inflammation may be associated with these lesions. The banana-shaped bodies stain grey with haematoxylin and eosin and contain neutral mucopolysaccharides and glycoproteins. These bodies appear to be an infectious agent (as yet unidentified).

**Method of diagnosis:**

- History.
- Death following a period of cold weather (less than 20°C).
- Histopathology.

**Predisposing conditions:**

Exposure to cold temperatures, especially in latitudes removed from the equator.

**Effect on host:**

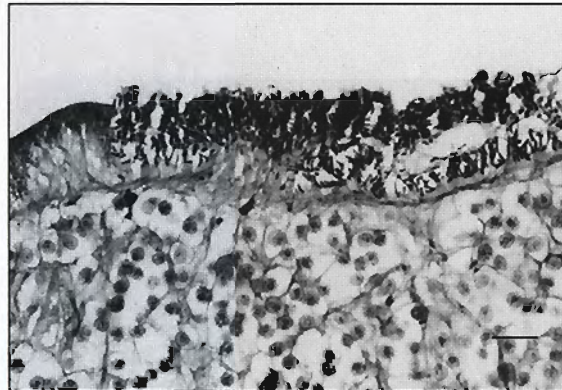
Rapid death in large numbers.

**Treatment:**

None.

**Prevention:**

Ensure temperature is maintained above 20°C, preferably above 22°C, by the use of plastic tenting (glass-house effect) and/or use heaters in culture ponds. Alternatively, rear clams at a warmer location closer to the equator where they are not exposed to low winter temperatures.



**Figure 11.13** Banana-shaped bodies in the mantle epithelium of a young juvenile *Tridacna gigas* affected by winter mortality (periodic acid-schiff stain, shell length 1 cm) (bar is 25 µm)

### Chilling

|                                 |   |                        |  |
|---------------------------------|---|------------------------|--|
| <b>Species affected:</b>        | Probably all species.   | <b>Effect on host:</b> | Usually fatal once secondary infections established.   |
| <b>Geographic distribution:</b> | Wherever clams are cultured and the winter temperature falls below the clam's normal temperature range (less than 20–22°C).   | <b>Treatment:</b>      | None.  |
| <b>Cause:</b>                   | Hypothermia.  | <b>Prevention:</b>     | <ul style="list-style-type: none"> <li>• Culture clams at latitudes closer to the equator where the winters are warmer (higher than 21°C to 22°C).</li> <li>• Heat culture tanks.</li> </ul> |
| <b>Gross signs:</b>             | Retracted mantle, reduced response to external stimuli, and finally death. Younger juvenile clams die more readily than do older ones.  |                        |  |
| <b>Histopathology:</b>          | Secondary bacterial infections and ciliate protozoan infestation are common.  |                        |  |
| <b>Method of diagnosis:</b>     | <ul style="list-style-type: none"> <li>• History of exposure to cold weather.</li> <li>• Lack of significant histopathology.</li> </ul>   |                        |  |
| <b>Predisposing conditions:</b> | Culture of clams in small bodies of water (aquaria) which undergo large temperature fluctuations; culture of clams in latitudes where the temperature falls below 20°C during winter. |                        |  |



**Heat stress**

**Species affected:** *Tridacna gigas*; probably all species.

**Geographic distribution:** Wherever clams are cultured.

**Cause:** Overheating (hyperthermia); exposure to temperatures of 35°C or more, the upper limit of the normal physiological range of the clam; the longer the exposure, the greater the mortality.

**Gross signs:** Mantle retraction, death.

**Method of diagnosis:**

- History of exposure to high temperatures (>35°C).
- Lack of significant histopathology.

**Predisposing conditions:** Culture of clams in shallow, static aquaria in full tropical sunlight.

**Effect on host:** Lethal if prolonged.

**Treatment:** Place in cool, aerated water (e.g. 25°C).

**Prevention:**

- If using small aquaria or tanks, place these in larger tanks of water, the latter covered with solar-shield aluminium foil. This latter body of water will help to dissipate any excess heat from the small aquaria or tanks.
- Alternatively circulate water from a large reservoir of water shaded from the sun's heating, or from the open sea.
- The use of a heavy sun screen mesh alone is not sufficient to prevent the excessive heating of small aquaria.

**Gas bubble disease**

**Species affected:** *Tridacna gigas*, *Tridacna crocea*, *Hippopus hippopus*; probably all species are susceptible.

**Geographic distribution:** Wherever clams are cultured.

**Cause:** Supersaturation of water with atmospheric gases which are then released from the water within the clam's tissues.

**Gross signs:** Clams of various sizes and ages may be affected. Translucent air blisters appear in the siphonal mantle (Figure 11.14). Small clams may float to the surface of the water.

**Histopathology:** The presence of large clear vacuoles in the tissues not associated with an inflammatory reaction (Figure 11.15).

**Methods of diagnosis:**

- Gross or sub-gross examination together with the above history.
- Histopathology.

**Predisposing conditions:**

- Supersaturated warm water entering a cooler culture tank containing the clams.

- Atmospheric gases under pressure in the pumping system caused by, for example, a leak in the supply line prior to the pump or an air pocket in the supply line.

**Effect on host:** This condition is lethal if it is severe.

**Treatment:** None.

**Prevention:** Allow for temperature and atmospheric gas pressure equilibration of pumped water prior to use in any tank containing clams. Provide adequate aeration of all pumped and heated sea water prior to use in tanks containing clams.

**Further reading:** Bisker and Castagna (1985), and Malouf et al. (1972).



**Figure 11.14** A preserved *Tridacna gigas* showing numerous gas bubbles in the siphonal mantle (shell length 8 cm, formalin fixed)



**Figure 11.15** Section of the siphonal mantle of *Tridacna gigas* showing a large gas bubble (H & E stain, shell length 3 cm) (bar is 157 µm)

**Bleaching**

**Species affected:** All species susceptible.

**Geographic distribution:** Wherever clams are cultured.

**Cause:** Uncertain. Lack of sufficient light of the correct wavelength (usually sunlight) and temperature stress suspected.

**Gross signs:** Pale mantle (Figure 11.16); deaths in young juvenile clams.

**Histopathology:** A reduced number of zooxanthellae in the siphonal mantle.

**Method of diagnosis:**

- History of excessive shading; hyperthermia; hypothermia.
- Gross examination.
- Histopathology.

**Predisposing conditions:**

- Shading of very young juvenile clams by an excessive growth of filamentous algae in culture tanks.
- A prolonged period of high water turbidity.
- Hyperthermia >35°C.
- Hypothermia <19–20°C.

**Effect on host:** May be lethal if prolonged; the younger the clams, the quicker the deaths.

**Treatment:** Unknown; one 20 cm *Tridacna gigas* held in the dark for five weeks, died within one week of being returned to normal sunlight.

**Prevention:**

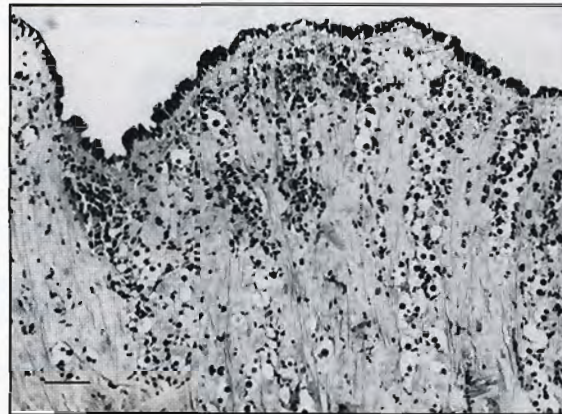
- Culture clams in clear water away from the outlets of large rivers which carry high loads of sediment during the wet season.
- Control growth of filamentous algae in young juvenile clam cultures.



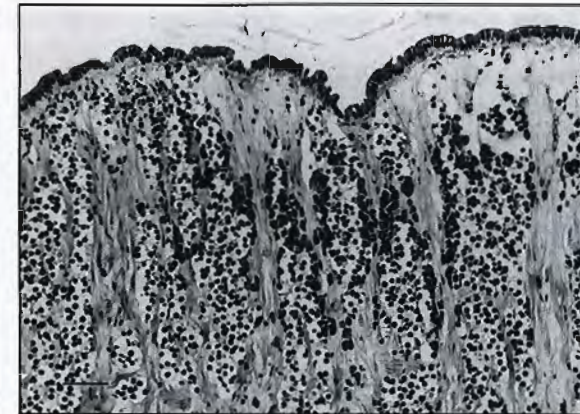
**Figure 11.16** *Tridacna gigas* with bleached area on the siphonal mantle (30 cm shell length)

### Nitrogen deficiency

|                                 |  |
|---------------------------------|--|
| <b>Species affected:</b>        | <i>Tridacna gigas</i> ; probably all species susceptible.  |
| <b>Geographic distribution:</b> | Wherever clams are cultured.   |
| <b>Cause:</b>                   | Lack of nitrogen in the culture water.   |
| <b>Gross signs:</b>             | Siphonal mantles are paler than normal.  |
| <b>Histopathology:</b>          | A low density of zooxanthellae in the siphonal mantle (Figures 11.17 and 11.18).   |
| <b>Method of diagnosis:</b>     | <ul style="list-style-type: none"> <li>• Gross examination for the intensity of the colour of the siphonal mantle.</li> <li>• Histopathology of the siphonal mantle.</li> </ul>    |
| <b>Predisposing conditions:</b> | <ul style="list-style-type: none"> <li>• Rapidly growing clams.</li> <li>• High density of clams.</li> </ul>   |
| <b>Effect on host:</b>          | Reduced growth rate.   |
| <b>Treatment/prevention:</b>    | <ul style="list-style-type: none"> <li>• Give small doses of nitrogen fertilizer e.g. ammonium sulfate or ammonium nitrate (20 µg).</li> <li>• Reduce stocking density.</li> </ul> |



**Figure 11.17** Low concentration of zooxanthellae in a *Tridacna gigas* with a pale siphonal mantle (H & E stain, shell length 22 cm) (bar is 35 µm)



**Figure 11.18** High concentration of zooxanthellae in the siphonal mantle of a normal *Tridacna gigas* (H & E stain, shell length 20 cm) (bar is 35 µm)

### Reduced salinity

|                                 |  |
|---------------------------------|--|
| <b>Species affected:</b>        | <i>Hippopus porcellanus</i> ; probably all species.  |
| <b>Geographic distribution:</b> | Wherever clams are cultured.   |
| <b>Cause:</b>                   | The exposure of clams to fresh water for one hour or more.   |
| <b>Gross signs:</b>             | Death.   |
| <b>Histopathology:</b>          | Areas of inflammation may be seen in the gills of clams which do not die acutely.  |
| <b>Method of diagnosis:</b>     | <ul style="list-style-type: none"> <li>• History.</li> <li>• Measurement of water salinity.</li> </ul>   |
| <b>Predisposing conditions:</b> | Use of fresh water or low saline dips to control parasites, micropredators, etc.   |
| <b>Effect on host:</b>          | Lethal.  |
| <b>Treatment:</b>               | None.  |
| <b>Prevention:</b>              | <ul style="list-style-type: none"> <li>• Reduce the time of exposure e.g. to 15 or 30 minutes.</li> <li>• Try using a low saline dip.</li> <li>• Use alternative treatments for parasites and micropredators, for example, manual removal by scrubbing.</li> </ul> |

### Increased salinity

|                                 |  |
|---------------------------------|--|
| <b>Species affected:</b>        | <i>Tridacna gigas</i> ; probably all species.  |
| <b>Geographic distribution:</b> | Wherever clams are cultured.   |
| <b>Cause:</b>                   | Excess salinity, > 45 ppt.   |
| <b>Gross signs:</b>             | Shell valves closed during the day.  |
| <b>Method of diagnosis:</b>     | <ul style="list-style-type: none"> <li>• History.</li> <li>• Check the salinity of the water.</li> </ul> |
| <b>Predisposing conditions:</b> | Evaporation from static culture tanks.   |
| <b>Effect on host:</b>          | Probably fatal if prolonged.   |
| <b>Treatment:</b>               | Add fresh water to reduce the salinity to 34–35 ppt.   |
| <b>Prevention:</b>              | Check salinity of tanks regularly (weekly).  |

### Pyramidellid gastropods (snails)

**Species affected:** All species, especially land-nursery juveniles.

**Geographic distribution:** Australia, Solomons, Philippines, Guam, Palau, Papua New Guinea, Indonesia.

**Cause:** *Tathrella ireclalei* and *Turbonilla* sp. Taxonomic problems with this family; it has been suggested the two species are the same (Hugh Govan, pers. comm. 1991).

**Gross signs:** Juvenile clams retracting mantle.

**Histopathology:** Not done.

**Methods of diagnosis:** Pyramidellids feed on the edge of the mantle of clams at night (Figure 11.19). They suck the haemolymph from the clam's mantle.

Hundreds may appear on larger clams during daytime. The snails congregate underneath shells or substrata underneath clams.

**Life history:** Complex combination of planktonic larval and direct development. Fertilised egg to metamorphosis about two weeks. Sexually mature about 40–50 days. Lifespan 4–5 months.

**Predisposing conditions:** Under culture conditions in tanks without filtration the larval can appear.

**Effect on host:** Weakness and eventual death for smaller juvenile clams.

**Treatment:**

- Check clams at night — clean off obvious snails.
- Completely clean tank and disinfect with 100 ppm Cl.
- Scrub shells to remove egg cases.

**Prevention:** As for treatment.



**Figure 11.19** Pyramidellid gastropod snails showing extended, feeding proboscis on the mantle edge of a juvenile *Tridacna gigas* (snails are each about 6 mm long) (photo: R. Cummings)

## Quarantine protocol for the export of giant clams

### 12.1 Why have a protocol?

The purpose of this protocol is to facilitate the export of larval and juvenile giant clams of *Tridacna* and *Hippopus* species into Indo-Pacific countries, where these clams have been depleted with a minimal risk of introducing pathogens or noxious agents.

### 12.2 Principles of quarantine protocol

- When live animals are moved from one place to another, the risk of introducing a pathogen or noxious agent is never zero. However, this risk can be minimised by good quarantine procedures.
- It is not sufficient to simply sample a batch of clams for export on one occasion in order to prevent the potential transfer of a pathogen. The system under which the clams are bred and reared needs to be disease free. This can be achieved by good hygiene principles, minimal stress and regular monitoring.
- Quarantine in the importing country is an added precaution against carrier status of undetected endemic infections of low prevalence which may become epizootic under the stress of shipment or culture conditions in the importing country.
- The export of clams as young as possible (larval or juvenile) greatly reduces the risk of pathogen transfer or carrier states.
- As little is known about the pathogens and parasites of the giant clam, any of the following conditions in a batch of clams will render it unsuitable for export:

- (i) the presence of any lesion (inclusion bodies or focal necrosis, for example) which when examined by transmission electronmicroscopy indicates the presence of a virus;
- (ii) the presence of any protozoan associated with an inflammatory or degenerative lesion or a protozoan known to be pathogenic for other classes of marine animals;
- (iii) the presence of metazoan parasites which cause a lesion in the clams or which are known to be pathogenic for other classes of marine animals;
- (iv) the presence of a fungal infection which causes lesions (for example, necrosis or inflammation in the clams);
- (v) the presence of bacteria associated with lesions or bacteria pathogenic for other classes of marine animals;
- (vi) the presence of rickettsia or chlamydia infected tissues; or
- (vii) the presence of unexplained lesions or mortalities.

The presence of symbiotic or opportunist protozoa (usually seen in sick or dying clams) will **not** stop the export of the clams.

- In order to facilitate the detection of any abnormality or mortality and to give personnel in both exporting and importing countries confidence in this proposed quarantine system, factors other than strict quarantine matters need to be addressed. These include stress reduction and manner of transport.
- A declaration that this protocol has been adhered to, and summarising the results of the monitoring, will need to be signed by representatives of both the clam culture facility and the government testing laboratory (Appendix 1 of this chapter).



## 12.3 Protocol for exporting country

### 12.3.1 Broodstock

- Broodstock clams will be observed regularly over two weeks in the field before transfer to the hatchery for spawning. Alternatively, transfer clams to spawning tanks at least one week prior to spawning for close observation. This enables the detection and removal of unhealthy clams.
- Scrub/clean the external shell of each clam with a 60 mg/L free chlorine solution to remove all marine animals and excess algae prior to placing them in the spawning tanks.
- Clean, disinfect, rinse and dry the tanks and other culture facilities prior to the introduction of the breeder clams (Box 12.1). This reduces the entry of pathogens and intermediate hosts into the spawning environment.
- Minimise stress (environmental, nutritional, traumatic). Stress-induced losses are often difficult to verify and would confuse the true health status of the clams.
- Maintain clams in 25 µm filtered water.
- Remove ova and sperm from spawning tank immediately after spawning.

### 12.3.2 Larval and juvenile clams

- Maintain in 1 µm filtered water.
- Use a batch system for each crop of larvae. Each crop is kept separate and is placed into ponds which have previously been cleaned, disinfected and dried prior to use (Box 12.1).
- All 1 µm filters to be duplicated and located externally to each pond.

- Filters should be cleaned at least every second day. They should be rinsed in filtered water, disinfected in 60 mg/L free chlorine for 60 minutes, and finally rinsed several times in 1  $\mu\text{m}$  filtered seawater or freshwater before being replaced. At any sign of deterioration they should be discarded.

### **Box 12.1**

#### *Cleaning and disinfection of culture facilities: exporting country*

##### **Cleaning**

All pond liners, pipes, nets, buckets, boots, etc. should undergo a thorough mechanical cleaning, preferably using a 1% solution of sodium hydroxide (10 g NaOH/L water) by means of a brush or by using a pressure spraying machine at a minimum temperature of 60°C.

##### **Disinfection**

Following cleaning, all the tanks and equipment are dried and sprayed with an iodophor solution containing 50–100 mg/L free iodine. Alternatively a chlorine solution containing 60 mg/L free chlorine can be used for disinfection. With chlorine solution use, contact time is 60 minutes, or the equipment is immersed in water and sodium hypochlorite is added in sufficient amounts so that a residual chlorine concentration of at least 10 mg/L remains after 30 minutes. All surfaces will be kept wet with disinfecting solution during the 30 minutes period.

##### **Rinsing**

All facilities are rinsed free of disinfectant using 1  $\mu\text{m}$  filtered seawater or freshwater.

##### **Drying**

Water is emptied/removed from all surfaces which are then allowed to dry. The culture facilities are now ready for the next batch of clams.

- All other animals must be excluded from the quarantine system.
- All quarantine ponds and facilities to be identified as such and be in a restricted area.
- Access to the quarantine system should be restricted. Only trained, authorised staff should service these clams. They will service these clams before proceeding to service other clams on any one day.
- A daily log is to be kept of each batch. It should include details of the following: cleaning, nutrient applications, any abnormalities, mortalities, water quality, filter changes, water exchange rates, water temperature and weather (sunshine/rain/cloud).
- Each batch of clams is to be monitored for a minimum of six months, even if some of the batch is exported during larval life.
- Eggs or larvae are randomly sampled at week 0, and juvenile clams at week 3 and every 8 weeks thereafter. Place samples in 3 to 5% formalised sea water for histopathology. The procedure to be followed and the minimum sample size required are shown in Box 12.2.
- All stress to be eliminated or minimised.
- Construct plastic or shade cloth walls, at least 2 m tall, around the ponds to stop aerosol drift contamination.
- A separate set of equipment is to be used for each pond. Staff will disinfect their legs and feet with a 60 mg/L free chlorine solution before entry into rearing ponds.
- Should a pathogen (virus, protozoan, fungus or parasite) be detected in any of the clams or if there is an unexplainable mortality, or lesions in the clams of a particular batch, then that batch will not be approved for export or if the batch has already been exported the consignee in the importing country will be notified immediately.

### Box 12.2

#### *Laboratory examination of larval and juvenile clams: exporting country*

The following procedure is proposed:

- Sample clams randomly to detect a 2% prevalence of a disease, unless there are sick, abnormal or stunted clams which should be preferentially sampled.
- Fix day 0 eggs or veligers and 3, 8, 16, etc. week old clams in 3 to 5% formalised sea water with a piece of coral rubble as a buffer.
- Examine clams grossly and sub-grossly for the presence of abnormalities and parasites.
- Examine clams histologically for lesions (evidence of pathogens) including viruses, protozoa, metazoa, fungi and bacteria.
- If any lesions are presumptively associated with bacteria or fungi, further samples will be collected and cultured accordingly.
- If any lesions are presumptively associated with viruses and protozoa, further samples will be collected into 3% glutaraldehyde in cacodylate buffer and the lesions examined under the electron microscope.
- If any lesions are presumptively associated with metazoa, further samples will be collected and the parasites dissected out of the tissues.
- Clams are to be cultured for *Perkinsus* sp. according to the method in Ray (1966).
- The minimum sample size to provide 95% confidence that infected specimens will be included in the clams sampled, assuming a minimum prevalence of infection equal to or greater than 2%, is 140 for a batch size of 1000; 145 for a batch size of 10 000; and 150 for a batch size of 100 000 or more.

The use of filtered water, multiple filters, batch systems, disinfection, plastic or shade cloth walls, separate equipment, security and authorised staff is to exclude as far as is possible the entry of pathogens and intermediate hosts of such pathogens.

Regular use of a log helps to ensure that the system is maintained and provides a record which may help to detect the likely source of a disease should it occur. Laboratory monitoring is a more sensitive way of detecting the presence of a pathogen.

Stress reduction is aimed at reducing losses from environmental factors which are often difficult to verify and would confuse the true health status of the clams.

### Box 12.3

#### *Summary of export protocol requirements*

The essential elements of these protocols, which are to prevent the translocation of diseases, pathogens and parasites with the clams, are as follows:

- a separate batch system for each lot of clams
- thorough physical cleaning, disinfection, rinsing and drying between batches
- filtering of all incoming water
- recording what is done, including sickness and deaths
- monitoring lesions, pathogens and parasites on the 2% prevalence level on at least two occasions by gross examination and histopathology.

Appendix: Form of declaration that export protocol has been adhered to

(A) CERTIFICATE OF ORIGIN

**I Identification of clams**

Species: .....  
Broodstock: .....  
Date of spawning: .....  
Number of clams in batch for export: .....  
Batch number/identification: .....

**II Source of clams**

Name and address of exporter: .....

Place of origin of clams: .....

**III Destination of clams**

Name and address of consignee: .....

.....

.....

**IV Sanitary information**

(a) Owner's declaration

I, ....., (block letters) being the owner/manager of the clams identified in Part 1 of this certificate declare that:

- (1) The clams for export (batch no. .... ) are from the same batch as those submitted for testing in accord with the attached 'protocol for exporting country'.
- (2) The clams have been bred and reared according to the attached 'protocol for exporting country'.
- (3) No unaccountable mortalities or signs of clinical disease have been seen in clams located either at the hatchery facilities or in the adjacent sea.
- (4) The log book(s) for batch no. .... are complete and accurate.

.....  
Owner/manager

.....  
Date

**(B) VETERINARY EXAMINATION CERTIFICATE FOR HATCHERY OF ORIGIN**

I, ....., (block letters) being a veterinary pathologist employed by..... certify in regard to the clams listed in Part I of this certificate that:

- (1) After due enquiry I have no reason to doubt the owner's/manager's declaration.
- (2) I have inspected the log book(s) for batch no. .... and have found them to provide adequate evidence that management procedures specified in the 'protocol for exporting country' have been complied with.
- (3) Over the last 12 months, no unaccountable mortality or signs of clinical disease have been seen in clams at the hatchery facilities or in the adjacent sea.
- (4) No clinical disease or significant pathogen (refer definitions in quarantine protocol for export of clams) which would stop the export of the clams, has been detected in batch no. .... held in quarantine.
- (5) During the pre-export quarantine, the clams were subjected to the following test(s) with negative results.

| date  | age   | number tested | test(s) |
|-------|-------|---------------|---------|
| ..... | ..... | .....         | .....   |
| ..... | ..... | .....         | .....   |
| ..... | ..... | .....         | .....   |

.....  
 Veterinary Pathologist

.....  
 Official stamp and date



## Quarantine protocol for the import of giant clams

### 13.1 Why have a protocol?

The purpose of this protocol is to facilitate the importation of larval and juvenile giant clams of *Tridacna* and *Hippopus* species into Indo-Pacific countries, where these clams have been depleted, with a minimal risk of introducing pathogens or noxious agents. When live animals are moved from one place to another, the risk of introducing a pathogen or noxious agent is never zero. However this risk can be minimised by good quarantine procedures both in the exporting and in the importing country.

### 13.2 Aims of quarantine in the importing country

- To detect endemic infection of low prevalence which may have been missed by the observations and tests conducted in association with the quarantine protocol in the exporting country.
- To prevent the release of any pathogen or noxious agent which may not have been detected, into the natural environment in the importing country.
- To facilitate the above by encouraging good hygiene practices, regular monitoring of sickness and mortality rates and by careful laboratory examinations.

The system under which the clams are quarantined in the importing country needs to be disease-free; otherwise it will not be known whether a pathogen or noxious agent, which might appear in the quarantine clams, came from the exporting country or from the local environment of the importing country.

### 13.3 Protocol for importing country

- Clams are to be imported as young as possible (larvae or young juvenile) to reduce the risk of a carrier status.
- A separate set of facilities (ponds, pumps, etc.) is to be used for each batch of clams imported.
- All such quarantine facilities are to be identified as such in a restricted area.
- Access to the quarantine facilities are to be restricted to trained and authorised staff.
- All other animals (trochus, fish) are to be excluded from the quarantine area.
- Each set of facilities are to be thoroughly cleaned, disinfected and dried prior to use by each new batch of imported clams (Box 13.1).
- The clams can be maintained in unfiltered water. This is a compromise to allow the entry of both phyto and zooplankton for the nutrition of the baby clams. However, it will also allow the entry of infected organisms such as the infective zoospores of *Perkinsus* spp (4-5  $\mu\text{m}$  in size) and so may confuse the issue of the origin of any pathogen which may appear in the clams during the quarantine period. Preferably clams should be maintained in 1  $\mu\text{m}$  filtered water and laboratory cultured algae of suitable type, quality and nutrients be added at regular intervals to avoid the above problem.
- All filters are to be duplicated and located externally to each pond.
- Filters should be cleaned at least every second day. They should be rinsed in filtered water, disinfected in 60 mg/L free chlorine for 60 minutes, and finally rinsed several times in 1  $\mu\text{m}$  filtered seawater or freshwater before being replaced. At any sign of deterioration they should be discarded.

- The outflow water from the quarantine ponds will be disposed of into a land-based sump (for example, sand trench) to prevent the spread of any pathogen or noxious agent present in the imported clams into the local marine environment.
- A daily log is to be kept of each batch. It should include details of the following: cleaning, nutrient applications, any abnormalities, mortalities, water quality, filter changes, water exchange rates, water temperature and weather (sunshine/rain/cloud).
- Each batch of clams to be monitored for a minimum of three months.
- Random samples to be collected for laboratory examination at 6 weeks and at 12 weeks after the time of arrival of the clams in the importing country. The tests will take at least one week. If the veterinary laboratory has a copy of the Anatomy and Pathology manual from the ACIAR Giant Clam Project, identification of problems will be facilitated.

Each sampling will include a sample of randomly collected clams for gross examination and *Perkinsus* species culture, and another sample of randomly collected clams, preserved in 3 to 5% seawater formalin (with coral for a buffer) for histopathology (Box 13.2). Gross examination, histopathology and *Perkinsus* culture should be completed within one week.

- All stress is to be minimised. Unnecessary stress will cause sickness and death which will may mask the presence of a pathogen or noxious agent.
- A separate set of equipment is to be used for each pond. Staff must disinfect their legs and feet with a 60 mg/L free chlorine solution before entry into rearing ponds.

The use of filtered water, multiple filters, batch systems, disinfection, separate equipment, security and authorised staff is to exclude as far as is possible the entry of local endemic pathogens and predators and intermediate hosts of such pathogens and to prevent the spread of possible pathogens into the local environment.

Regular use of a log helps to ensure that the system is maintained and provides a record which may help to detect the likely source of a disease should it occur. Laboratory monitoring is a more sensitive way of detecting the presence of a pathogen.

Stress reduction is aimed at reducing losses from environmental factors which are often difficult to verify and would confuse the true health status of the clams with reference to infectious disease.

### **Box 13.1**

#### *Cleaning and disinfection of culture facilities: importing country*

##### **Cleaning**

All pond liners, pipes, nets, buckets, boots, etc. should undergo a thorough mechanical cleaning, preferably using a 1% solution of sodium hydroxide (10 g NaOH/L water) by means of a brush or by using a pressure spraying machine at a minimum temperature of 60°C.

##### **Disinfection**

Following cleaning, all the tanks and equipment are dried and sprayed with an iodophor solution containing 50–100 mg/L free iodine. Alternatively a chlorine solution containing 60 mg/L free chlorine can be used for disinfection. With chlorine solution use, contact time is 60 minutes, or the equipment is immersed in water and sodium hypochlorite is added in sufficient amounts so that a residual chlorine concentration of at least 10 mg/L remains after 30 minutes. All surfaces will be kept wet with disinfecting solution during the 30 minutes period.

##### **Rinsing**

All facilities are rinsed free of disinfectant using 1 µm filtered seawater or freshwater.

##### **Drying**

Water is emptied/removed from all surfaces which are then allowed to dry. The culture facilities are now ready for the next batch of clams.

**Box 13.2**

*Laboratory examination of larval or juvenile clams: importing country*

The following procedure is proposed:

- Sample clams randomly to detect a 2% prevalence of a disease, unless there are sick, abnormal or stunted clams which should be preferentially sampled.
- A sample of clams (fresh, unpreserved) should be examined grossly and sub-grossly for the presence of abnormalities and parasites.
- The above clams should then be cultured for *Perkinsus* sp. according to the method of Ray (1966).
- Another sample of clams should be preserved in 3 to 5% sea water formalin buffered with a small piece of coral rubble.
- Examine clams histologically for lesions (evidence of pathogens) including viruses, protozoa, metazoa, fungi, bacteria and rickettsia.
- If any samples are presumptively associated with bacteria or fungi, further samples may be collected and cultured accordingly.
- If any lesions are presumptively associated with viruses and protozoan, further samples will be collected into 3% glutaraldehyde in cacodylate buffer and the lesions examined under the electron microscope.
- If any lesions are presumptively associated with metazoa, further samples will be collected and the parasites dissected out of the tissues prior to identification.

- The minimum sample size to provide 95% confidence that infected specimens will be included in the clams sampled, assuming a minimum prevalence of infection equal to or greater than 2%, is 140 for a batch size of 1000; 145 for a batch size of 10 000; and 150 for a batch size of 100 000 or more.

**Comment**

Where there are limited resources, the bare minimum requirements are for the gross and sub-gross examination of clams (second procedure) and for subsequent histopathology (fourth and fifth procedures) on two occasions — at 6 weeks and at 12 weeks after arrival in the importing country. The requirement for the second procedure can be done by the clam culture facility in the importing country while the histopathology can be performed either by a regional laboratory in the importing country or be sent to a laboratory in a collaborating overseas country. As noted earlier, if a laboratory has a copy of the ACIAR Anatomy and Pathology Manual, it will facilitate identification of disease or parasites.

The sixth, seventh and eighth procedures are optional and carried out if either the importing or exporting country requires further clarification on the origin and type of pathogen or noxious agent which may present itself.

The requirement for culture of *Perkinsus* species (third procedure) is highly desirable considering the widespread nature of this infection in giant clams and the damaging effects it has produced on other mollusc species. Both the culture requirement and the detection of this protozoan using an average quality microscope are relatively simple.

### 13.4 Criteria for the release of imported clams into the local marine environment

As little is known about the pathogens and parasites of the giant clams, any of the following conditions in a batch of clams will render it *unsuitable* for release from quarantine into the marine environment in the importing country:

- the presence of any lesion (for example, inclusion bodies or focal necrosis) which when examined by transmission electronmicroscopy indicates the presence of a virus;
- the presence of any protozoan associated with an inflammatory or degenerative lesion or a protozoan known to be pathogenic for other classes of marine animals;
- the presence of metazoan parasites which cause a lesion in the clams or which are known to be pathogenic for other classes of marine animals;
- the presence of a fungal infection which causes lesions (for example, necrosis or inflammation in the clams);
- the presence of rickettsia or chlamydia infected tissues (rickettsia is most likely found worldwide and has been found in indigenous clams from the Great Barrier Reef, Philippines and Tonga. These rickettsia vary from country to country, and a strain which may be harmless in one country could, when translocated, cause problems. Further research is needed to categorise these rickettsia in giant clams);
- the presence of unexplained lesions;
- the presence of bacteria associated with lesions or bacteria pathogenic for other classes of marine animals;
- the presence of any unexplained mortality.

If any of the preceding are found during either routine screening examinations or during the examination of sick clams, then the entire batch of clams will be destroyed and the facilities will be thoroughly disinfected. The presence of symbiotic or opportunist protozoan (usually seen in sick or dying clams) will not stop the release of the clams. The officer in charge should notify the person in charge of the hatchery in the exporting country of the outcome as soon as possible.

In order to facilitate the detection of any abnormality or mortality associated with a potential pathogen or noxious agent, stress needs to be minimised.

**Box 13.3**

*Summary of import protocol requirements*

The essential elements of these protocols, which are to prevent the translocation of diseases, pathogens and parasites with the clams, are as follows:

- a separate batch system for each lot of clams
- thorough physical cleaning, disinfection, rinsing and drying between batches
- filtering of all incoming water
- disposal of all waste water into a land-based sump
- recording what is done, including sickness and deaths
- monitoring lesions, pathogens and parasites on the 2% prevalence level on at least two occasions by gross examination and histopathology.

# References

- Adams, T. 1988. Giant clams in Fiji. South Pacific Commission Workshop on Inshore Fishery Resources, Noumea, New Caledonia. March 1988. Background Paper 50.
- Alcazar, S.N., Solis, E.P., and Alcala, A.C. 1987. Serotonin-induced spawning and larval rearing of the China clam, *Hippopus porcellanus* Rosewater (Bivalvia: Tridacnidae). *Silliman Journal*, 33, 65-72.
- Anderson, I.G. 1990. Diseases in Australian invertebrate aquaculture. In: Proceedings of the Fifth International Colloquium on Invertebrate Pathology and Microbial Control. Adelaide, Society of Invertebrate Pathology, 38-48.
- Balouet, G. 1979. *Martellia refrigens* – considerations of the life cycle and development of Aber's disease in *Ostrea edulis*. *Marine Fisheries Review*, 41, 64-66.
- Barker, J.R., Crawford, C.M., Shelley, C.C., Braley, R.D., Lucas, J.S., Nash, W.J. and Lindsay S. 1988. In: Copland, J.W., and Lucas, J.S., ed., Giant clams in Asia and the Pacific. Canberra, ACIAR Monograph No. 9, 225-228.
- Beckvar, N. 1981. Cultivation, spawning and growth of the giant clams *Tridacna gigas*, *Tridacna derasa* and *Tridacna squamosa* in Palau, Caroline Islands. *Aquaculture*, 24, 21-30.
- Bisler, R., and Castagna, M. 1985. The effects of various levels of air-supersaturated seawater on *Mercenaria mercenaria* (Linne), *Mulinia lateralis* (Say), and *Mya arenaria* (Linne), with reference to gas-bubble disease. *Journal of Shellfish Research*, 5, 97-102.
- Braley, R.D. 1984. Reproduction in the giant clams *Tridacna gigas* and *T. derasa* in situ on the North-Central Great Barrier Reef and Papua New Guinea. *Coral Reefs*, 3, 221-227.
- Braley, R.D. 1985. Serotonin induced spawning in giant clams (Bivalvia: Tridacnidae). *Aquaculture*, 47, 321-325.
- Braley, R.D. 1986. Reproduction and recruitment of giant clams and some aspects of their larval and juvenile biology. Ph.D. Thesis, University of New South Wales, 297 p.
- Braley, R.D. 1988a. The status of giant clam stocks and potential for clam mariculture in Tuvalu. A report prepared for Fisheries Division, Funafuti, Tuvalu and the FAO South Pacific Aquaculture Development Project, Suva, Fiji.
- Braley, R.D. 1988b. Reproductive condition and season of the giant clams *Tridacna gigas* and *T. derasa* utilising a gonad biopsy technique. In: Copland, J.W., and Lucas, J.S., ed., Giant clams in Asia and the Pacific. Canberra, ACIAR Monograph No. 9, 98-103.
- Braley, R.D. 1989. A giant clam stock survey and preliminary investigation of pearl oyster resources in the Tokelau Islands. A report prepared for the Department of Agriculture and Fisheries, c/- Tokelau Affairs, Apia, W. Samoa and the FAO South Pacific Aquaculture Development Project, Suva, Fiji.



- Braley, R.D. 1990. Manual for the culturing of giant clams. Publication of James Cook University, 108 p.
- Braley, R.D. 1992. Improved method to ship *Tridacna gigas* seed. Aquaculture, in press.
- Braley, R.D., Nash, W.J., Lucas, J.S. and Crawford, C.M., 1988. Comparison of different hatchery and nursery culture methods for the giant clam *Tridacna gigas*. In: Copland, J.W., and Lucas, J.S., ed., Giant clams in Asia and the Pacific. Canberra, ACIAR Monograph No. 9, 110-114.
- Braley, R.D., Sutton, D., Mingoia, S.S.M., and Southgate, P.C. 1992. Passive greenhouse heating, recirculation, and nutrient addition on nursery phase *Tridacna gigas*: growth boost during winter months. Aquaculture, in press.
- Castagna, M., and Kraeuter, J.N. 1981. Manual for growing the hard clam *Mercenaria*. Special Report in Applied Marine Science and Oceanography No. 249. Virginia Institute of Marine Science, Wackapreague, VA, 110 p.
- Chu, F.E., Webb, K.L., Hepworth, D., and Roberts, M. 1982. The acceptability and digestibility of microcapsules by larvae of *Crassostrea virginica*. Journal of Shellfish Research, 2, 29-34.
- Chu, F.E., Webb, K.L., Hepworth, D., and Casey, B. 1987. Metamorphosis of larvae of *Crassostrea virginica* fed microencapsulated diets. Aquaculture, 64, 185-197.
- Coffen, S.S. and Charles, A.T. 1991. Production economics of shellfish aquaculture in Atlantic Canada: a preliminary analysis. Aquaculture and Fisheries Management, 22(2), 193-202.
- Crawford, C.M., Nash, W.J., and Lucas, J.S. 1986. Spawning induction, and larval and juvenile rearing of the giant clam, *Tridacna gigas*. Aquaculture, 58, 281-295.
- Dalzell, P., Lindsay, S. and Patiali, H. 1990. Resource stock survey of sedentary reef invertebrates and fisheries on the island of Niue. SPC-FAO publication.
- Elston, R.A., and Peacock, M.G. 1984. A rickettsiales-like infection in the Pacific razor clam, *Silliqua patula*. Journal of Invertebrate Pathology, 44, 84-96.
- Firdausy, C. and Tisdell, C. 1989. Seafarming as a part of Indonesia's economic development strategy - seaweed and giant clam mariculture as cases. Research Reports or Papers in Economics of Giant Clam Mariculture, No. 2.
- Fisher, C.R., Fitt, W.K. and Trench, R.K. 1985. Photosynthesis and respiration in *Tridacna gigas* as a function of irradiance and size. Biological Bulletin, 169, 230-245.
- Fitt, W.K., Fisher, C.R. and Trench, R.K. 1984. Larval biology of tridacnid clams. Aquaculture, 39, 181-195.
- Gibbons, M.C., and Blogoslawski, W.J. 1989. Predators, pests, parasites and diseases. In: Manzi, J.J., and Castagna, M., ed., Clam mariculture in North America. Amsterdam, Elsevier, 167-200.
- Goggin, C.L., and Lester, R.J.G. 1987. Occurrence of *Perkinsus* species (Protozoa, Apicomplexa) in bivalves from the Great Barrier Reef. Diseases of Aquatic Organisms, 3, 113-117.

- Goggin, C.L., and Lester, R.J.G. 1990. Rickettsiales-like infection in the gills of *Tridacna crocea* from the Great Barrier Reef. *Journal of Invertebrate Pathology*, 56, 135-138.
- Guillard, R.R.L. 1975. Culture of phytoplankton for feeding marine invertebrates. In: Smith, W.L., and Chanley, M.H., ed., *Culture of marine invertebrate animals*. New York, Plenum Press, 29-60.
- Gulka, G., Chang, P.W., and Marti, K.A. 1983. Prokaryotic infection associated with a mass mortality of the sea scallop, *Placopecten magellanicus*. *Journal of Fish Diseases*, 6, 355-364.
- Gwyther, J. and Munro, J.L. 1981. Spawning induction and rearing of larvae of tridacnid clams (Bivalvia: Tridacnidae). *Aquaculture*, 24, 197-217.
- Harshbarger, J.C., Chang, S.C., and Otto, S.V. 1977. Chlamydia (with phages), mycoplasmas, and rickettsiae in Chesapeake Bay bivalves. *Science*, 196, 666-668.
- Heslinga, G.A. 1988. The MMDC Bulletin. Newsletter of the Micronesian Mariculture Demonstration Center. March, 1988, V.3.1.
- Heslinga, G.A. and Fitt, W.K. 1987. The domestication of tridacnid clams. *Bioscience*, 37, 332-339.
- Heslinga, G.A., Perron, F.E. and Orak, O. 1984. Mass culture of giant clams (F. Tridacnidae) in Palau. *Aquaculture*, 39, 197-215.
- Heslinga, G.A. and Watson, T.C. 1985. Recent advances in giant clam mariculture. *Proceedings of the Fifth International Coral Reef Congress*, 5, 531-537.
- Heslinga, G.A., Watson, T.C. and Isamu, T. 1988. Giant clam research and development in Palau. In: Copland, J.W., and Lucas, J.S., ed., *Giant clams in Asia and the Pacific*. Canberra, ACIAR Monograph No. 9, 49-50.
- Heslinga, G.A., Watson, T.C. and Isamu, T. 1990. Giant clam farming. Pacific Fisheries Development Foundation (NMFS/NOAA), Honolulu, Hawaii, 179 pp.
- Huguenin, J.E. and Colt, J. 1989. Design and operating guide for aquaculture seawater systems. *Developments in Aquaculture and Fisheries Science*, 20. Elsevier, Amsterdam, 264 p.
- Humphrey, J.D. 1988. Disease risks associated with translocations of shellfish, with special reference to the giant clam. In: Copland, J.W., and Lucas, J.S., ed., *Giant clams in Asia and the Pacific*. Canberra, ACIAR Monograph No. 9, 241-244.
- Jameson, S.C. 1976. Early life history of the giant clams *Tridacna crocea* (Lamarck), *Tridacna maxima* (Roding), and *Hippopus hippopus* (Linnaeus). *Pacific Science*, 39, 219-233.
- La Barbera, M. 1975. Larvae and larval development of the giant clams *Tridacna maxima* and *Tridacna squamosa* Bivalvia: (Tridacnidae). *Malacologia*, 15(1), 69-79.
- Laing, I. 1987. The use of artificial diets in rearing bivalve spat. *Aquaculture*, 65, 243-249.

- Langdon, C.J., and Slegfried, C.A. 1984. Progress in the development of artificial diets for bivalve filter feeders. *Aquaculture*, 39, 135-153.
- Lee, B. 1988. Giant clam farming – is there a bright future? *Australian Fisheries*, 47(7), 27-31.
- Lewis, A.D., and Ledua, E. 1988. A possible new species of *Tridacna* (Tridacnidae: Mollusca) from Fiji. In: Copland, J.W., and Lucas, J.S., ed., *Giant clams in Asia and the Pacific*. Canberra, ACIAR Monograph No. 9, 82-84.
- Lucas, J.S. 1988a. Giant clams: description, distribution and life history. In: Copland, J.W., and Lucas, J.S., ed., *Giant clams in Asia and the Pacific*. Canberra, ACIAR Monograph No. 9, 21-31.
- Lucas, J.S. 1988b. Testing an antifouling treatment for ocean-nursery meshes. In: Copland, J.W., and Lucas, J.S., ed., *Giant clams in Asia and the Pacific*. Canberra, ACIAR Monograph No. 9, 170-172.
- Lucas, J.S., Braley, R.D., Crawford, C.M. and Nash, W.J. 1988. Selecting optimum conditions for ocean-nursery culture of *Tridacna gigas*. In: Copland, J.W., and Lucas, J.S., ed., *Giant clams in Asia and the Pacific*. Canberra, ACIAR Monograph No. 9, 129-132.
- Lucas, J.S., Ledua, E. and Braley, R.D. 1990. A new species of giant clam from Fiji and Tonga. ACIAR Working Paper No. 33, 8 p.
- Lucas, J.S., Ledua, E. and Braley, R.D. 1991. *Tridacna tevoroa* Lucas, Ledua, and Braley: a recently-described species of giant clam (bivalvia: Tridacnidae) from Fiji and Tonga. *The Nautilus*, 105(3), 92-103.
- Lucas, J.S., Nash, W.J. and Braley, R.D. 1989a. Recent advances in mariculture of the giant clam *Tridacna gigas*. In: Chavez, E.A., ed., *Proceedings of the Australia-Mexico Workshop on Marine Sciences, Mexico*, pp. 457-467.
- Lucas, J.S., Nash, W.J., Crawford, C.M. and Braley, R.D. 1989b. Environmental influences on growth and survival during the ocean-nursery rearing of giant clams, *Tridacna gigas* (L.). *Aquaculture*, 80, 45-61.
- Luckner, G. 1983. Diseases of Mollusca: Bivalvia. In: Kinne, O., ed., *Diseases of marine animals*, vol. II. Hamburg, Biologische Anstalt, 477-961.
- McLaughlin, J.J.A. and Zahl, P.A. 1957. Endozoic algae. In: Henry, S.M. ed., *Symbiosis*. Academic Press, N.Y., 1, 257- 297.
- Malouf, R., Keck, R., Maurer, D., and Epifanio, C. 1972. Occurrence of gas-bubble disease in three species of bivalve molluscs. *Journal of the Fisheries Research Board Canada*, 29, 588-589.
- Meade, J.W. 1989. *Aquaculture management*. New York, Van Nostrand Rienhold.
- Mingoa, S.S.M. and Shelley, C.C. 1988. Growth and chemistry of the shells of juvenile *Tridacna gigas*. In: Copland, J.W., and Lucas, J.S., ed., *Giant clams in Asia and the Pacific*. Canberra, ACIAR Monograph No. 9, 213-216.

- Munro, J.L. 1985. Economic and social aspects of the development of mariculture systems for giant clams (Tridacnidae: Bivalvia) in the Australasian region and the Western Pacific. 1. Production parameters and calculated harvests. International Giant Clam Mariculture Project, Discussion Paper, 2, 9 p.
- Munro, J.L. 1986. Status of giant clam stocks and prospects for clam mariculture in the Central Gilbert Islands group. International Center for Living Aquatic Resources and Management, Manila, Philippines.
- Munro, J.L. 1988. Growth, mortality and potential aquaculture production of *Tridacna gigas* and *T. derasa*. In: Copland, J.W., and Lucas, J.S., ed., Giant clams in Asia and the Pacific. Canberra, ACIAR Monograph No. 9, 218-220.
- Munro, J.L. and Gwyther, J. 1981. Growth rates and mariculture potential of tridacnid clams. Proceedings of the Fourth International Coral Reef Symposium, 2, 633-636.
- Munro, J.L. and Heslinga, G.A. 1983. Prospects for the commercial cultivation of giant clams (Bivalvia: Tridacnidae). Proceedings of the Gulf and Caribbean Fisheries Institute, 35, 122-134.
- Norton, J.H. and Jones, G.W. 1992. Giant clams: an anatomical and histological atlas. Canberra, ACIAR Monograph No. 14, In press.
- Perron, F.E., Heslinga, G.A. and Fagolimul, J.O. 1985. The gastropod *Cymatium muricinum*, a predator on juvenile tridacnid clams. Aquaculture, 49, 211-221.
- Ray, S.M. 1966. A review of the culture method for detecting *Dermocystidium marinum*, with suggested modifications and precautions. Proceedings of the National Shellfish Association, 54, 55-69.
- Rosewater, J. 1965. The family Tridacnidae in the Indo-Pacific. Indo-Pacific Mollusca, 1, 347-396.
- Rosewater, J. 1982. A new species of *Hippopus* (Bivalvia: Tridacnidae). Nautilus, 96, 3-6.
- Roubal, F.R., Masel, J., and Lester, R.J.G. 1989. Studies on *Marteilia sydneyi*, agent of QX Disease in the Sydney rock oyster, *Saccostrea commercialis*, with implications for its life cycle. Australian Journal of Marine and Freshwater Research, 40, 155-167.
- Shang, Y.C. 1981. Aquaculture economics: basic concepts and methods of analysis. Boulder, Colorado, Westview Press.
- Shelley, C.C., and Reid, R.G.B. 1988. An improved gonad biopsy technique for *Hippopus hippopus*. In: Copland, J.W., and Lucas, J.S., ed., Giant clams in Asia and the Pacific. Canberra, ACIAR Monograph No. 9, 95-97.
- Sindermann, C.J. 1988. Vibriosis in clam larvae. In: Sindermann, C.J., and Lightner, D.V., ed., Disease diagnosis and control in North American aquaculture. Amsterdam, Elsevier, 307 p.
- Sirenko, B.I., and Scarlato, O.A. 1991. *Tridacna rosewateri* (sp. n.). A new species of giant clam from Indian Ocean (Bivalvia: Tridacnidae). La Conchiglia, No. 261, 4-9.

- Solis, E.P., Onate, J.A., and Naguit, M.R.A. 1988. Growth of laboratory-reared giant clams under natural and laboratory conditions. In: Copland, J.W., and Lucas, J.S., ed., Giant clams in Asia and the Pacific. Canberra, ACIAR Monograph No. 9, 201-206.
- Southgate, P.C. 1988. Use of microencapsulated diets in the culture of giant clam larvae. In: Copland, J.W., and Lucas, J.S., ed., Giant clams in Asia and the Pacific. Canberra, ACIAR Monograph No. 9, 155-160.
- Southgate, P.C. 1990. Aspects of the nutrition of giant clams with emphasis on the development of an artificial microencapsulated diet. PhD Thesis, James Cook University of North Queensland, 290 p.
- Stephenson, A. 1934. The breeding of reef animals, Part II. Invertebrates other than corals. Scientific Report Great Barrier Reef Expedition, 1928-29, 3, 247-272.
- Sutton, D.C., and Muir, P.R. 1990. Bacterial diseases in cultured tropical marine invertebrates in Australia. In: Proceedings of the Fifth International Colloquium on Invertebrate Pathology and Microbial Control. Adelaide, Society of Invertebrate Pathology, 405.
- Tisdell, C. 1989a. Market for giant clam shells: report on a survey of retailers and wholesalers in Southeast Queensland, Australia. Research Reports or Papers in Economics of Giant Clam Mariculture, No. 1.
- Tisdell, C. 1989b. Market for giant clams as aquarium specimens: report on a survey of retailers of supplies for saltwater aquariums. Southeast Queensland, Australia. Research Reports or Papers in Economics of Giant Clam Mariculture, No. 3.
- Tisdell, C., and Menz, K. 1988. Socioeconomic considerations in giant clam mariculture. In: Copland, J.W., and Lucas, J.S., ed., Giant clams in Asia and the Pacific. Canberra, ACIAR Monograph No. 9, 246-249.
- Tisdell, C.A., Lucas, J.S., and Thomas, W.R. 1990. An analysis of the cost of producing giant clam (*Tridacna gigas*) seed. Research Reports and Papers in Economics of Giant Clam Mariculture, no. 11, Department of Economics, University of Queensland, Australia.
- Ukeles, R. 1971. Nutritional requirements in shellfish culture. In: Proceedings of the Conference on Artificial Propagation of Commercially Valuable Shellfish, October 22-23, 1969. College of Marine Studies, University of Delaware, Newark, Delaware.
- Wada, S. 1954. Spawning of tridacnid clams. Japan Journal of Zoology, 11, 273-285.
- Walne, P.R. 1974. Culture of bivalve molluscs. Fishing News (Books) Ltd., 23 Rosemount Ave., West Byfleet, Surrey, England, 173 p.
- Wattanuchariya, S., and Panayoutou, T. 1982. The economics of aquaculture: the case of catfish in Thailand. In: Aquaculture Economics Research in Asia, Proceedings of a Workshop held in Singapore 2-5 June 1982, ICLARM, Manila.
- Wolf, P.H. 1979. Life cycle and ecology of *Martellia sydneyi* in the Australian oyster, *Crossostrea commercialis*. Marine Fisheries Review, 41, 70-72.

# Appendix

## Equipment needed to set up a hatchery and farm, estimated costs and sources of supply

| Equipment description   | Estimated cost <sup>a</sup> | Company name and address   |
|---|-----------------------------|--|
| Hemocytometer<br>Improved Neubauer Ruling (Cat. No. 301032)                   | 42.00                       | Selby Scientific<br>PO Box 1263  |
| Sedgewick Rafter Counters (Cat. No. 299635)                                   | 37.50                       | Milton Centre, Qld 4064<br>Ph. (07) 371 1566<br>Ph. (088) 177412 toll free<br>Fax (07) 870 3769                    |
| Graduated pipettes  |                             |  |
| 1 mL (Glass — \$9.18)   | 12.53                       |  |
| 2 mL (Glass — \$9.18)   | 12.60                       |  |
| 5 mL (Glass — \$10.50)  | 13.13                       |  |
| 10 mL (Glass — \$11.22)   | 14.18                       |  |
| Microscope — compound   |                             | or<br>Weber Scientific Int. Ltd<br>40 Udney Park Road<br>Teddington<br>Middlesex TW11 9BG, U.K.<br>Ph. 441977-6630 |
| Model CHK-Olympus built-inlight source w/10x ocular and 4x,10x,40x objectives | 795.00                      |  |
| Binocular   | 630.00                      |  |
| Monocular   |                             |  |
| Microscope — dissecting   |                             |  |
| Model VE31 — 10x ocular   | 265.00                      |  |
| Model VE32 — 20x ocular   |                             |  |
| Fixed 2x objective and 15x available  |                             |  |
| Set of ocular pair  | 90.00                       |  |
| pH Meter (Cat.No. HANI PICCOLO 2)   | 190.00                      |  |

<sup>a</sup> Prices are in \$Aust. and, as far as possible, have been checked as correct at May 1992.

## HATCHERY AND NURSERY CULTURE OF GIANT CLAMS

| Equipment description   | Estimated cost | Company name and address  |
|---|----------------|---|
| <b>Plastic Beakers</b>  |                |   |
| 250 mL (units of 6 — Cat. No. 221013)   | 4.90           | See addresses on previous page  |
| 600 mL (units of 4 — Cat. No. 221017)   | 6.00           |   |
| 1000 mL (units of 3 — Cat. No. 221019)  | 10.00          |   |
| 2000 mL (units of 1 — Cat. No. 221021)  | 16.90          |   |
| Minimum/Maximum Thermometers (ZEAL P3060)   | 20.00          |   |
| Tissue Culture Plates 24 well (box 50) (can use instead of Sedgewick Rafter Counters) | 58.00          | Disposable Products P/L,<br>8 Willingdon Street,<br>Archerfield Qld. 4108.<br>Ph. (07) 274 2000<br>Fax (07) 274 1231                |
| <b>Clark Splasher Pools</b>   |                |   |
| 4.5 m dia. x 0.9 m ht. (Cat. No. 1536)  | 239.00         | Clark Rubber,<br>Unit 11, 41 Lysaght Street,<br>Acacia Ridge Qld. 4110.<br>Ph. (07) 345 9100<br>Fax (07) 345 9580                   |
| — liner only 4.5 m x 0.9 m  | 99.00          |   |
| — heavy duty liner (Cat.No.1548)  | 199.00         |   |
| 3.05 m dia. x 0.9 m ht.   | 105.00         |   |
| — liner only 3.05 m x 0.9 m   | 59.00          |   |
| Spare plastic pool clips /each  | 0.35           |   |
| Patches   | 1.00           |   |
| Glue  | 2.75           |   |
| <b>Dry Pool Chlorine</b>  |                |   |
| 40 kg drum  | 179.00         |   |
| 10 kg drum  | 57.90          |   |
| Waterwick — 310 m roll  | 496.00         | Hunter Irrigation P/L,<br>Shop 20, Salamander Shopping Centre,<br>Salmonder Bay NSW 2301.<br>Ph. (049) 33 3111<br>Fax (049) 71 4193 |

| Equipment description                                    | Estimated cost | Company name and address   |
|--|----------------|--|
| 90 mm black polypipe (ridged) Grade 9<br>— 75m roll      | 628.12         | Harvey Hose Supplies P/L,<br>1898 Ipswich Road,<br>Rocklea Qld. 4106.<br>Fax (07) 875 1427   |
| Nylox thick black plastic mesh for 'lines', 'covered'    |                |  |
| — 30 m x 12 mm (87 piece)                                | 190.81         |  |
| — 30 m x 40 mm x 60mm (87 piece)                         | 133.20         |  |
| — 30 m x 25 mm (87 piece)                                | 208.40         |  |
| — 30 m x 6 mm (86 piece)                                 | 208.40         |  |
| 25 mL Adipoyl Chloride (Cat. No. A5377)                  | 84.50          | Phoenix Scientific,<br>P.O. Box 208,<br>Alderley Qld. 4051.<br>Ph. (07) 3554944<br>Ph. (088) 77 7834 toll free<br>Fax (07) 355 4998                                  |
| 25 g Thiamine Hydrochloride (Cat. No. T4625)             | 16.00          |  |
| 25 g Chloramphenicol Crystalline (Cat. No. CO378)        | 42.60          |  |
| 100 g Streptomycin Sulphate (Cat. No. S6501)             | 48.55          |  |
| 1 g Serotonin (Cat. No. H7752)                           | 28.85          |  |
| 0–50 $\mu$ L Socorex Pipette (Cat. No. SOC-821-0050)     | 195.00         |  |
| 50–200 $\mu$ L Socorex Pipette (Cat. No. SOC-821-0200)   | 195.00         |  |
| 200–1000 $\mu$ L Socorex Pipette (Cat. No. SOC-821-1000) | 195.00         |  |
| Pack (1000) Propypropylene Tips (Cat. No. TIP-1058)      | 28.00          |  |
| Pack (1000) Propypropylene Tips (Cat. No. TIP-1004)      | 32.00          |  |
| Pack (250) Propypropylene Tips (Cat. No. TIP-JUM)        | 37.00          |  |
| Plastic graduated cylinders                              |                |  |
| — 50 mL (code 1078)                                      | 6.10           | Rhone Poulenc Laboratory Products,<br>1/126–134 Fairbank Road,<br>Clayton South, Vic. 3169.<br>Ph. (03) 550 4666<br>Ph. (008) 33 9467 toll free<br>Fax (03) 558 1544 |
| — 100 mL (code 1079)                                     | 7.75           |  |
| — 500 mL (code 1081)                                     | 17.20          |  |
| Plastic Beakers  |                |  |
| — 1 L (code 1808)  | 7.55           |  |
| — 2 L (code 1809)  | 12.60          |  |
| — 3 L (code 1811)  | 24.90          |  |
| — 5 L (code 1812)  | 37.60          |  |



## HATCHERY AND NURSERY CULTURE OF GIANT CLAMS

| Equipment description   | Estimated cost | Company name and address  |
|---|----------------|---|
| <b>Pasteur Pipettes (Borosilicate Glass)</b>                        |                | Rhone Poulenc Laboratory Products<br>See address on previous page   |
| 1 box (250) 146 mm (Cat. No. 72050/575)                             | 22.05          |   |
| 4 boxes of above or more  | 20.05          |   |
| 1 box (250) 229 mm (Cat.No.72050/900)                               | 29.50          |   |
| 4 boxes of above or more  | 26.85          |   |
| <b>Larval Depression Slides</b>                                     |                |   |
| 1 box single cavity   | 7.40           | Lomb Scientific,<br>P.O. Box 52,<br>Banksia NSW. 2216.<br>Ph. (02) 597 7333<br>Telex 21 656                               |
| 1 box double cavity   | 10.50          |   |
| <b>Oyster Mesh Rolls</b>  |                | The Cove' Oysters P/L.,<br>PMB 26,<br>Oyster Cove,<br>Via Williamtown NSW 2301.<br>Ph. (049) 82 4832<br>Fax (049) 82 4436 |
| 6 x 6 mm (920 x 30 m) roll per metre                                | 4.01           |   |
| above per roll  | 120.30         |   |
| 12 x 12 mm (920 x 30 m) roll per metre                              | 3.97           |   |
| above per roll  | 119.20         |   |
| 20 x 20 mm (920 x 30 m) roll per metre                              | 3.86           |   |
| above per roll  | 115.75         |   |
| <b>Anti-fish net</b>  |                |   |
| Oyster B.O.P. black (mesh dia. 19sq.) 2 m x 200 m - Code No. 693182 | 250.00         |   |
| Oyster B.O.P. black (mesh dia. 32sq.) 2 m x 200 m - Code No. 693304 | 250.00         |   |
| <b>Nally Bins — No. 7</b>   | 15.20          | Nally Ltd.,<br>P.O. Box 122,<br>Minto NSW. 2566.<br>Ph. (02) 820 2222<br>Fax (02) 820 2227                                |
| Lids to suit  | 11.85          |   |
| Orange Lug Box (Product Code 65990)                                 | 31.40          |   |

| Equipment description                 | Estimated cost | Company name and address   |
|---------------------------------------|----------------|--|
| 1 roll (100 m) 7/0.50 building wire   | 44.00          | Haymans Electrical,<br>P.O. Box 1094,<br>Brisbane Qld. 4001.<br>Ph. (07) 369 8400<br>Fax (07) 369 3651             |
| 1 packet TY525MX cable ties           | 9.50           |  |
| 1 metre grey conduit                  | 1.40           |  |
| 350 mm diameter upwellers             | 65.00          | Plastic Fabrications P/L,<br>1092 Cambridge Road<br>Cambridge Tas. 7170.<br>Ph. (002) 48 5511<br>Fax (002) 48 5408 |
| 450 mm diameter upwellers             | 57.00          |  |
| 1 mini coil rope                      | 4.55           | Local Boat Shop.   |
| 12" football float                    | 3.44           |  |
| 12" ball float                        | 9.18           |  |
| 6" polystyrene floats                 | 2.40           |  |
| 750 mL epoxy resin                    | 30.00          |  |
| 1kg Epigen Kit No. 503                | 48.57          | Local Boat Shop.   |
| Pressure Coupling 100 mm              | 17.11          | Local Hardware Shop.   |
| Pressure Reducing Bush 100 x 50 mm    | 11.52          |  |
| Pressure Reducing Bush 100 x 80 mm    | 12.06          |  |
| Pressure Reducing Coupling 50 x 25 mm | 4.76           |  |
| Pressure Tee 25 mm                    | 2.66           |  |
| Pressure Valve Socket 50 mm           | 5.08           |  |
| Pressure Faucet Adaptor 50 mm         | 6.80           |  |
| Pressure Elbow 25 mm                  | 1.84           |  |
| Pressure Pipe (per metre)             | 2.02           |  |

## HATCHERY AND NURSERY CULTURE OF GIANT CLAMS

| Equipment description                     | Estimated cost | Company name and address              |
|---|----------------|---------------------------------------|
| 1 - 4'6" (135 cm) steel fence posts       | 3.48           | Local Plumbing & Hardware Shop.       |
| 1 - 14" metal cutting-off wheel           | 10.62          |                                       |
| 1/2" joiners                              | 1.38           |                                       |
| 1/2" poly tees                            | 0.60           |                                       |
| 1/2" poly caps                            | 6.30           |                                       |
| 25 mm class 12 PVC pipe                   | 15.46          |                                       |
| 25m m PVC elbows                          | 1.89           |                                       |
| 25 mm PVC caps                            | 1.23           |                                       |
| 25 mm PVC tees                            | 2.16           |                                       |
| 25 mm PVC sockets                         | 1.49           |                                       |
| 50 mm class 12 PVC pipe                   | 40.97          |                                       |
| 50 mm PVC elbows                          | 4.54           |                                       |
| 100 mm double junctions                   | 14.15          |                                       |
| 100 x 90 sewer junctions                  | 9.21           |                                       |
| 100 x 90 sewer bends                      | 5.41           |                                       |
| 100 mm level straights                    | 9.21           |                                       |
| 100 mm sewer pipe                         | 35.25          |                                       |
| Cuno Zetapor Cartridge 0.2 $\mu$          | 207.50         | Local Chemical & Engineering Company. |
| Cuno Zetapor Cartridge 0.6 $\mu$          | 135.00         |                                       |
| Cuno Zetapore 12 MPI                      | 205.00         |                                       |
| Transparent Housing AP 11T                | 72.50          |                                       |
| 1 $\mu$ micro wynd. cartridge (Code PPPY) | 11.81          |                                       |
| 10 $\mu$ cartridge (Code PPC)             | 11.31          |                                       |
| 1 kg natural gelcoat brush-waxed          | 9.00           | Local Fibreglass Supplier etc.        |
| 1.5 kg olive green pigment                | 29.13          |                                       |
| 500 mL hardner MEKP                       | 12.96          |                                       |
| Rena 150 watt heaters                     | 24.77          |                                       |
| Acetone (4 L)                             | 15.80          |                                       |
| Brushes - 3"                              | 5.00           |                                       |
| Airline Tubing 50 m                       | 4.95           |                                       |

| Equipment description   | Estimated cost | Company name and address   |
|---|----------------|--|
| Cord Clamps x 24 (use with airline tubing)  | 1.66           | Local Fibreglass Supplier etc.   |
| Other fittings, i.e. t-pieces, connectors, end stop valves, crosses   | < 2.00         |  |
| Air blower SD4M — 3 phase, 1.5 m (3)/min. capacity 1/2 m deep v-belt pulley drive for generator/engine  | 1330.00        | CIG Transpower,<br>P.O. Box 40,<br>Archerfield Qld. 4108.<br>Ph. (07) 212 4222<br>Fax (07) 277 8229            |
| 3 phase blower — 0.95 kW SN4N   | 1018.00        | C'wealth Industrial Gases,<br>P.O. Box 40,<br>Archerfield Qld. 4108.<br>Ph. (07) 212 4222<br>Fax (07) 277 8229 |
| Flanges to suit air blower  | 60.00          |  |
| Grundfoss LP80-160/149, 5.5 kW (= 7.37 hp)  | 1695.00        | Southern Cross,<br>45 Machinery Street,<br>Barra Qld. 4076.<br>Ph. (07) 375 3944<br>Fax (07) 375 4553          |
| Service kit for Grundfoss, No. 184 (48-50-83)   | 243.32         |  |
| Backing flanges to fit to 90 mm polypipe (x2)   | 90.00          |  |
| Onga 146 (oversized engine) to pump from storage tank into system or to elevated tank (suggest a good back-up pump also). If Onga 146 runs dry, materials required to repair: | 657.00         |  |
| Seal  | 75.00          |  |
| Impellor  | 48.60          |  |
| Diffuser  | 27.60          |  |
| Baffle  | 25.20          |  |
| Casings No. 301106  | 51.50          |  |
| Yokes No. 402061  | 39.60          |  |
| O-Rings No. 702180  | 6.70           |  |
| Diesel backup to turn 160 000 L over 2x/day — Onga 150 (cast iron pump case) + 4.5 hp Yanmar diesel   | 2100.00        |  |

## HATCHERY AND NURSERY CULTURE OF GIANT CLAMS

| Equipment description   | Estimated cost | Company name and address  |
|---|----------------|---|
| Onga 120 (2.7 amps)   | 300.00         | See preceding page.   |
| 50 mm pipe joiner   | 14.95          |   |
| 50 mm plastic ball valves                                       | 34.78          |   |
| black polypipe per metre  | 0.72           |   |
| 1 µm GAF bags PIS P1 (minimum order of 10 for all GAF bags)     | 5.40           | Swiss Screens P/L,<br>4/14 Randall Street,<br>Slacks Creek Qld. 4127.<br>Ph. (07) 209 5111<br>Fax (07) 808 2048 |
| 5 µm GAF bags PIS P5  | 4.70           |   |
| 10 µm GAF bags PIS P10  | 4.70           |   |
| 25 µm GAF bags PIS P25  | 4.70           |   |
| Normal Screening (Nytal) available in 1 metre x 102 cm wide     |                |   |
| 25 µm screening 0025HD-102 (18% open area)                      | 85.60          |   |
| 53 µm screening 270-53-102 (36% open area)                      | 44.60          |   |
| 100 µm screening 013-100-102 (39% open area)                    | 28.50          |   |
| 200 µm screening 007-200-102 (48% open area)                    | 25.60          |   |
| 500 µm screening GG38-0500 (50% open area)                      | 21.30          |   |
| 1000 µm screening GG20-1000 (61% open area)                     | 21.30          |   |
| Heavy Duty Screening (Nytal) available in 1 metre x 142 cm wide |                |   |
| 37 µm screening HD400-37 (30% open area)                        | 94.00          |   |
| 44 µm screening HD325-44 (31% open area)                        | 86.80          |   |
| 53 µm screening HD270-53 (35% open area)                        | 60.20          |   |
| 62 µm screening HD230-62 (35% open area)                        | 56.10          |   |
| 74 µm screening HD200-74 (35% open area)                        | 50.50          |   |
| 88 µm screening HD170-88 (35% open area)                        | 44.00          |   |
| 105 µm screening HD140-105 (36% open area)                      | 37.70          |   |
| Opaque Filter Housing Cartridges (Product Code FSC10P-BO)       | 55.20          |   |

| Equipment description                        | Estimated cost                       | Company name and address   |
|--|--------------------------------------|--|
| Rangefinder 1200<br>Carry case to suit       | 223.30<br>42.49<br>(Ex-stock Cairns) | Sokkisha P/L,<br>Unit 1, 131-133 Scott Street,<br>Cairns Qld. 4870.<br>Ph. (070) 31 5399<br>Fax (070) 31 5404                            |
|  |                                      | or   |
|  |                                      | Sokkisha P/L,<br>Unit 1, Montague Chase,<br>Cnr. Montague Street,<br>West End Qld. 4101.<br>Ph. (07) 846 3385<br>Fax (07) 844 3907       |
| Frippak Booster (Code DA1353) 440g           | 60.00                                | Rhone-Poulenc P/L,<br>66 Antimony Street,<br>Carole Park,<br>P.O. Box 61,<br>Goodna Qld. 4300.<br>Ph. (07) 271 1244<br>Fax (07) 271 3335 |
| Salinity 0-10% Refractometer (Cat.No.508-11) | 284.00                               | Crown Scientific,<br>P.O. Box 134,<br>Newstead Qld. 4006.<br>Ph. (07) 252 1066<br>Fax (07) 252 5664                                      |

## HATCHERY AND NURSERY CULTURE OF GIANT CLAMS

| Equipment description                          | Estimated cost | Company name and address   |
|--|----------------|--|
| Gilson Adjustable Pipetman P1000 (H23602)      | 340.00         | John Morris Scientific,<br>47 Brookes Street,<br>Bowen Hills Qld. 4006.<br>Ph. (07) 854 1713<br>Fax (07) 252 1067<br>Ph. 008 251 799 toll free |
| Gilson Adjustable Pipetman P5000 (H23603)      | 400.00         |  |
| Tips Natural C5000 per 1000 (G23969)           | 110.00         |  |
| Tips Natural C1000 per 1000 (G23894)           | 60.00          |  |
| YSI 5775 Membrane Kit standard                 | 20.50          |  |
| Pack (10) Hypo-leur needles 18g x 3"           | 30.00          | Lyppard Chemical P/L.,<br>149 Carpenter Street,<br>Brighton Vic. 3186.<br>Ph. (03) 592 7733  |
| Pack ( 5) Biopsy Needles 14g x 6" (No.2N2704T) | 30.00          |  |