

The Australian Centre for International Agricultural Research (ACIAR) was established in June 1982 by an Act of the Australian Parliament. Its mandate is to help identify agricultural problems in developing countries and to commission collaborative research between Australia and developing country researchers in fields where Australia has special research competence.

Where trade names are used this constitutes neither endorsement of nor discrimination against any product by the Centre.

## **ACIAR PROCEEDINGS**

This series of publications includes the full proceedings of research workshops or symposia organised or supported by ACIAR. Numbers in this series are distributed internationally to selected individuals and scientific institutions.

© Australian Centre for International Agricultural Research  
G.P.O. Box 1571, Canberra, A.C.T., 2601 Australia

St. George, T.D. and Peng Kegao (ed.) 1996. Bluetongue disease in Southeast Asia and the Pacific. Proceedings of the First Southeast Asia and Pacific Regional Bluetongue Symposium, Greenlake Hotel, Kunming, P.R. China, 22-24 August 1995. ACIAR Proceedings No. 66, 272p.

ISBN 1 86320 187 4

Editorial management and technical editing: E. and R. Beckmann, Canberra  
Pre-press production: Arawang, Canberra

# **Bluetongue Disease in Southeast Asia and the Pacific**

**Proceedings of the First Southeast Asia and Pacific Regional Bluetongue Symposium, Greenlake Hotel, Kunming, P.R. China, 22–24 August 1995**

*Editors: T.D. St. George and Peng Kegao*

## Veterinary Services in China

Some explanation will perhaps enhance the understanding of some of the papers from China where various terms for administrative areas are mentioned. This has a bearing on bluetongue as the responsibility for diagnosis and control is shared at various levels of government and associated veterinary services.

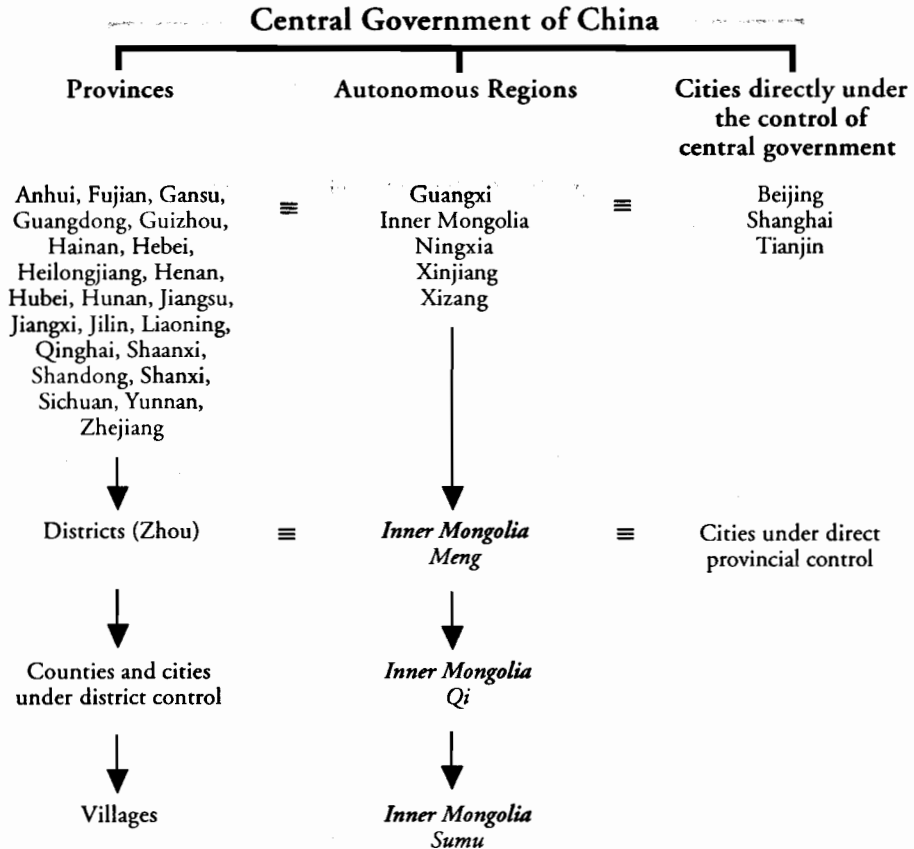

(The Inner Mongolia terms are shown in italics)

Every province and autonomous region has a provincial veterinary station and every district, county and village has a correspondingly titled veterinary station. Each level derives financial support from its own government level with some contribution from the veterinary station of the level above.

# Contents

Welcoming Address The First Southeast Asia and Pacific Regional Bluetongue Symposium <i>Feng Jinglan</i>	viii
<b>Epidemiology</b>	<b>1</b>
Introduction	2
A Short History of the Discovery of Bluetongue in the World <i>T.D. St. George</i>	3
The Global Distribution of Bluetongue <i>R.A. Hawkes</i>	6
Bluetongue Viruses in India: a Review <i>D. Sreenivasulu, M.V. Subba Rao and G.P. Gard</i>	15
Serological Study for Bluetongue in Thailand <i>Bunchong Apiwatnakorn, Prim Bura and Orapan Pasavorakul</i>	20
Recent Studies on Bluetongue in Peninsular Malaysia <i>S.S. Hassan, G.P. Gard, I. Polkinghorne, M.A. Abdul Rahman, A. Aziz Hussin, M. Maizan, M. Zainal and L. Aminah Kadariah</i>	23
Bluetongue Virus Research in Indonesia <i>I. Sendow, Sukarsih, E. Soleha, M. Pearce, S. Bahri and P.W. Daniels</i>	28
The History of Bluetongue in Australia and the Pacific Islands <i>T.D. St. George</i>	33
Bluetongue Virus Status in Papua New Guinea <i>I. Puana</i>	41
An Outbreak of Bluetongue in Cattle in Japan <i>Y. Goto, M. Yamakawa and Y. Miura</i>	42
Bluetongue History, Serology and Virus Isolation in China <i>Zhang Nianzu, Li Zhihua, Zhang Khaili, Hu Yuling, Li Gen, Peng Kegao, Li Huachun, Zhang Fuqiang, Ben Jin, Li Xinrong, Zhou Fuzhong and Liu Gui</i>	43
An Epidemiological Survey of Bluetongue in Yunnan Province, China <i>Bi Yunlong, Li Chundi, Li Shiyin, Qing Bo, Zhong Nan, Hu Jinfeng and Yang Ruilan</i>	51
Epidemiological Investigations and Control of Bluetongue Disease in Jiangsu Province, China <i>Zhu Changgui, Li Yamin, Shao Cuili, Xu Shibai and Zheng Tianran</i>	57
An Epidemiological Study of Bluetongue in Anhui Province, China <i>Zhou Weihai</i>	61
Epidemiological Investigations and Isolation of Bluetongue Virus in Gansu Province, China <i>Huang Xiu, Pu Shuying, Er Chengjun, Yang Chengyu, Wei Wanlian, Cheng Xiengfu, Zhang Chongxin, Li Xiaocheng and Liu Tianbin</i>	65
Bluetongue Epidemiological Survey and Virus Isolation in Xinjiang, China <i>Qin Qiyang, Tai Zhengguo, Wang Lijin, Luo Zhengqi, Hu Jun and Lin Hanliang</i>	67
The Isolation and Characterisation of Bluetongue Virus and Its Epidemiology in Shanxi Province, China <i>Lei Huaimin, Xu Jianming, He Chongli, Shao Jiangliang and Shi Xiayun</i>	72
A Serological Survey of Bluetongue in Cattle in Guangxi Province, China <i>Chen Libiao, Zhong Peiyi and Zhao Guoming</i>	76



Serological Survey of Bluetongue in Sheep and Cattle in Inner Mongolia <i>Mo Regen, Ao Fulai, Si Qin and Zhao Xinli</i>	78
Investigation of Bluetongue Disease in the Bayannur Meng of Inner Mongolia <i>Guo Zhaijun, Hao Jucui, Chen Jianguo, Li Zhihua, Zhang Khaili, Hu Yuling, Li Gen and Pu Long</i>	80
Differential Epidemiology of Bluetongue Antibodies in Ruminants in China <i>Zhang Fuqiang, Li Gen, Peng Kegao, Li Xinrong and N.T. Hunt</i>	84
Bluetongue Viruses in the Asian and Southeast Asian Region <i>G.P. Gard</i>	86
A Strain of Virus Isolated From <i>Culicoides homotomus</i> <i>Li Xiaocheng, Wu Shiyun, Cheng Yanxia, Cheng Zhongguo, Meng Guangxiao, Zhou Weihai and Su Genyuan</i>	90
Aetiological and Epidemiological Studies on Ibaraki Disease in Taiwan <i>Lu Yongsiu, Li Yungkung and Liou Pepper</i>	91
Epidemiological and Aetiological Studies on Chuzan Disease in Taiwan <i>Lu Yongsiu, Li Yungkung and Liou Pepper</i>	92
<b>Sentinel Herds</b>	<b>93</b>
Introduction	94
Australian National Arbovirus Monitoring Program - a Model for Studying Bluetongue Epidemiology in China <i>P.D. Kirkland, T. Ellis, L.F. Melville and S.J. Johnson</i>	95
Recent Experiences with the Monitoring of Sentinel Herds in Northern Australia <i>L.F. Melville, R. Weir, M. Harmsen, S. Walsh, N.T. Hunt, I. Pritchard and P.W. Daniels</i>	100
Establishment of Sentinel Herds to Monitor Bluetongue in China <i>Li Huachun, Li Zhihua, Zhou Fuzhong, Ben Jin, Zhang Khaili, Liu Gui, Li Chundi, Zhang Yingguo, Shi Wenbao, Zhao Jinguang, Wang Jiayen, Du Jinwen, Kong Dehui, Yang Guanghua, Niu Baosheng and Niu Yongfu</i>	106
Epidemiological Considerations in the Study of Bluetongue Viruses <i>P.W. Daniels, I. Sendow and L.F. Melville</i>	110
<b>Entomology</b>	<b>121</b>
Introduction	122
<i>Culicoides</i> Survey in Indonesia <i>Sukarsih, I. Sendow, S. Bahri, M. Pearce and P.W. Daniels</i>	123
Preliminary Results of Trapping for <i>Culicoides</i> in South China: Future Bluetongue Vector Studies <i>M.J. Muller and Li Huachun</i>	129
Analysis of the Vector and Overwintering Hosts of Bluetongue in Anhui Province, China <i>Zhou Weihai</i>	136
A Comparison of the Geographic Distribution and Dynamics of <i>Culicoides</i> in Anhui Province, China <i>Zhou Weihai, Su Genyuan, Cui Shoulong and Xue Chaoyang</i>	138
A Study on Laboratory Rearing of Dominant <i>Culicoides</i> in Anhui Province, China <i>Su Genyuan and Zhou Weihai</i>	139
A Comparison of Methods for Isolating Arboviruses from Insects <i>Li Xiaocheng, Cheng Zhongguo, Zhan Yanxia and Meng Guangxiao</i>	140
Application of the Polymerase Chain Reaction (PCR) Test with Insects in Studying Bluetongue Virus Activity <i>L.F. Melville, N.T. Hunt and P.W. Daniels</i>	141

<b>Entomology Workshop</b>	<b>146</b>
<i>Convened by H.A. Standfast and M.J. Muller</i>	
<b>Bluetongue Vector Surveillance in Yunnan and Sichuan Provinces of China</b>	<b>148</b>
<i>Li Huachun, Li Zhihua, Zhang Khaili, Liu Gui, Zhou Fuzhong and Shun Yourong</i>	
<b>Virology, Serology and Pathogenesis</b>	<b>149</b>
<b>Introduction</b>	<b>150</b>
<b>The Pathogenesis of Bluetongue Virus Infection of Cattle: a Novel Mechanism of Prolonged Infection in which the Erythrocyte Functions as a Trojan Horse</b>	<b>151</b>
<i>N.J. MacLachlan</i>	
<b>Research on the Basic Properties of Chinese Bluetongue Viruses</b>	<b>152</b>
<i>Li Zhihua, Zhang Khaili, Li Gen, Hu Yuling, Peng Kegao and Wu Dexing</i>	
<b>Identification of Local Chinese Strains of Bluetongue Virus to Serotype</b>	<b>156</b>
<i>Zhang Nianzu, Peng Kegao, Li Zhihua, Zhang Khaili, Li Huachun, Hu Yuling, Li Gen, Zhang Fuqiang, Li Xinrong and Ben Jin</i>	
<b>Regular Changes in Immunomorphology of Sheep Given Live Attenuated and Inactivated Bluetongue Vaccines</b>	<b>158</b>
<i>Chu Guifang, Wu Donglai, Yin Xunnan and Qu Xiangdong</i>	
<b>The Pathogenicity of Chinese Bluetongue Virus in Sheep, Deer and Goats</b>	<b>159</b>
<i>Zhang Khaili</i>	
<b>Identification of Monoclonal Antibody-defined Epitopes Validates the Bluetongue Competitive ELISA</b>	<b>160</b>
<i>B.T. Eaton, Wang Linfa and J.R. White</i>	
<b>Comparison of Competitive ELISA and Agar Gel Immunodiffusion Tests to Detect Bluetongue Antibodies in Ruminants in China</b>	<b>164</b>
<i>Ben Jin, Li Zhihua, Li Huachun, L.F. Melville, N.T. Hunt, Li Xinrong, Zhang Fuqiang and Zhang Nianzu</i>	
<b>Detection of Bluetongue in China by Polymerase Chain Reaction (PCR)</b>	<b>167</b>
<i>Peng Kegao, A.R. Gould, Li Huachun, Ben Jin, J.A. Kattenbelt, Li Xinrong and Zhang Fuqiang</i>	
<b>Studies of a Non-radioactive Gene Probe for Bluetongue Viruses</b>	<b>171</b>
<i>Peng Kegao, Li Zhihua and Li Gen</i>	
<b>Analysis of Local Isolates of Bluetongue Viruses in China by SDS-PAGE</b>	<b>172</b>
<i>Hu Yuling and Peng Kegao</i>	
<b>A Study of the ELISA Test for the Detection of Epizootic Hemorrhagic Disease (EHD) Virus Infection</b>	<b>173</b>
<i>Li Xiaocheng, Yang Chengyu, Zhang Yianxia, Cheng Xiengfu, Pu Shuying, Cheng Zhongguo, Meng Guangxiao and Li Baojia</i>	
<b>A Rapid ELISA Procedure for Detection of Antibody to Bluetongue Viruses</b>	<b>174</b>
<i>Yang Chengyu, Cheng Xiengfu, Ma Hongchao, Fan Gencheng, Li Xiaocheng and Pu Shuying</i>	
<b>A Serological Identification of Shandong Strain of Bluetongue Virus</b>	<b>175</b>
<i>Yang Chengyu, Pu Shuying, Ma Hongchao, Cheng Xiengfu, Li Xiaocheng, Fan Gencheng and Zhang Yianxia</i>	
<b>Serological Cross-reactions between Bluetongue and Epizootic Hemorrhagic Disease (EHD) Virus Groups in Agar Gel Immunodiffusion (AGID) Tests</b>	<b>176</b>
<i>Li Xiaocheng, Yang Chengyu, Chang Yanxia, Pu Shuying and Cheng Xiengfu</i>	
<b>A Comparison of BHK21, Vero and C6/36 Cell Lines in the Preparation of the AGID Antigen of Bluetongue Virus</b>	<b>177</b>
<i>Li Xiaocheng and Zhang Yianxia</i>	
<b>Enhancement of Growth of Bluetongue Viruses in Cell Cultures through Trypsin Treatment</b>	<b>178</b>
<i>Li Gen, Peng Kegao, Zhang Fuqiang and Li Xinrong</i>	

Comparison of the Value of AGID and ELISA Antigen in the ELISA Test for Bluetongue Viruses <i>Yang Chengyu, Chen Xiangfu, Ma Hongchao, Fan Gencheng, Li Xiaocheng and Pu Shuying</i>	179
<b>Vaccine and Control</b>	<b>181</b>
Introduction	182
Development of Bluetongue Virus Multicomponent Vaccines Using a Novel Baculovirus System <i>P. Roy</i>	183
Bluetongue Recombinant Vaccines <i>S.J. Johnson and P. Roy</i>	192
Studies on the Vaccination of Sheep with Bluetongue Virus Core-like Particles Produced by a Recombinant Baculovirus <i>M. Hosseini, R.J. Dixon, P.D. Kirkland and P. Roy</i>	198
Estimations of the Divergence of Bluetongue Viral Populations in Indonesia on the Basis of Virus Isolation and PCR Sequence Analysis <i>I. Sendow, I. Pritchard, P.W. Daniels and B.T. Eaton</i>	203
Molecular Epidemiology of Bluetongue Serotype 10 Virus from the Western United States <i>B.I. Osburn, C.C. de Mattos, C.A. de Mattos and N.J. MacLachlan</i>	208
Control of Bluetongue Disease with Attenuated Vaccine <i>Shun Yourong, Zhang Yuchun, Hu Zhiyou, Yuan Yudong, Wu Zhuoshou and Liu Gongchen</i>	214
Using Inactivated Vaccine to Prevent Bluetongue in Hubei Province, China <i>Zhou Yong, Cao Zhenghui, Cheng Yuankun, Li Zhihua, Peng Kegao, Zhang Khaili, Duan Jinrong, Zhang Xuezhi, Wang Fucui and Wu Jianzhang</i>	215
Development of Bluetongue Attenuated Vaccine in China <i>Zhang Nianzu, Li Zhihua, Zhang Khaili, Hu Yuling, Li Gen, Peng Kegao, Zhou Fuzhong, Li Huachun, Zhao Kuen and Liu Gui</i>	217
Cross-protection Studies of Bluetongue Viruses in Sheep <i>Li Zhihua, Zhang Khaili and Li Gen</i>	224
Development of Inactivated Vaccines for Bluetongue in China <i>Li Zhihua, Peng Kegao, Zhang Khaili, Li Gen, Hu Yuling, Zhou Fuzhong and Liu Gui</i>	227
Analysis of RNA of Inactivated Bluetongue Vaccine by PAGE <i>Peng Kegao, Li Zhihua and Wu Dexing</i>	231
The Prevention and Control of Bluetongue Disease in China <i>Wang Qinbo</i>	232
Developments and Advancements in the Prevention of Bluetongue Disease <i>Feng Jinglan</i>	234
<b>Open Forum and Finale</b>	<b>237</b>
Open Forum	238
Bluetongue Virus Infection of Postnatal Cattle <i>N.J. MacLachlan</i>	239
Evidence Against Congenital Bluetongue Virus Infection of Cattle and Virus in Semen <i>B.I. Osburn and N.J. MacLachlan</i>	244
Characteristics of Naturally-occurring Bluetongue Viral Infections of Cattle <i>L.F. Melville, R. Weir, M. Harmsen, S. Walsh, N.T. Hunt and P.W. Daniels</i>	245
Diagnostic Techniques for Bluetongue Viruses <i>P.D. Kirkland and T.D. St. George</i>	251

<b>Bluetongue — Its Impact on International Trade in Meat and Livestock</b> <i>G.I. Alexander, M.P. Alexander and T.D. St. George</i>	<b>254</b>
<b>Future Directions in Bluetongue Research</b> <i>P.D. Kirkland</i>	<b>259</b>
<b>Closing Address</b> The First Southeast Asia and Pacific Regional Bluetongue Symposium <i>Zhao Shi Kun</i>	<b>260</b>
<b>Participants</b>	<b>261</b>

# The First Southeast Asia and Pacific Regional Bluetongue Symposium

## Welcoming Address

Feng Jinglan\*

LADIES and gentlemen—I am very pleased to be the Honorary President of this Conference. It is indeed my great honour, on behalf of the Department of Animal Industry and Veterinary Medicine, Minister of Agriculture, China, and Professor Zhang Nianzu and Dr Peter Kirkland, the Co-Chairs of this Symposium, to welcome all representatives and friends from Australia, China, India, Indonesia, Papua New Guinea, Japan, Malaysia, New Zealand, Philippines, Thailand, United Kingdom, United States of America and Vietnam who are participating in this Symposium.

First of all, we would like to recognise and extend our appreciation for the well thought out preparations and hard work the Organising Committee has done for this event. This group consists of Professor Zhang Nianzu, Peng Kegao, Li Huachun, Dr Toby St. George, Neville Hunt, Dr Lorna Melville and Dr Peter Kirkland. Special thanks are due to Dr Toby St. George and Peng Kegao for the editorial work for the Symposium proceedings. We also appreciate the contribution offered by both the Yunnan Provincial Commission on Science and Technology, the Yunnan Provincial Bureau of Animal Husbandry and the Yunnan Tropical and Subtropical Animal Virus Disease Laboratory. Their input will ensure that this is a successful conference.

Since the first publication of a description of bluetongue by Theiler in South Africa in 1905, numerous studies have been conducted in many countries. A much better understanding of the characteristics and epidemiology of the virus has resulted from this research, particularly in the last 40 years. Much of the knowledge acquired has been directly applicable to the livestock industry. This Symposium provides the opportunity for researchers and scientists to exchange experience. The subjects under discussion will

enhance research and control of bluetongue disease which is widely distributed and can have devastating effects. I encourage you to take full advantage of this Symposium, by active participation in formal and informal discussions.

I would like to take this opportunity to briefly describe the current status of animal industries in China. During the last 15 years, since the implementation of the Reform and Opening-up policy, livestock industries have enjoyed rapid growth. In 1994, national meat production amounted to 45 million tonnes. Annual per capita consumption is: meat 33.8 kg, eggs 12.6 kg, milk 5.2 kg and aquaculture 18.3 kg. Milk production, in particular, is far below that of developed countries. China is a vast, populous nation, and offers great potential for further development but at the same time faces enormous challenges. We must continue to develop and protect livestock industries. Obviously, the prevention and control of livestock diseases is extremely important in these endeavours. Since the first isolation of bluetongue virus in the southern province of Yunnan in 1979, China has focused a great deal of effort on the diagnosis and immunology of the disease. At the present time we are vigorously pursuing regional trials of bluetongue vaccines, which we believe will provide a powerful tool for the prevention of disease. We would like to see an increase in cooperation and exchange among all those who are here today.

August is the hottest month of the year in China. However, Kunming, is known as the 'Spring City' because of its pleasant climate. I wish you all a successful and productive conference and an enjoyable stay in China that you will remember for years to come. Thank you.

---

\* Symposium Honorary President, Vice Director of the Department of Animal Industry and Veterinary Medicine, Ministry of Agriculture, Beijing, People's Republic of China.

# **Epidemiology**

# Introduction

THE epidemiology of bluetongue involves the interaction of five elements: the bluetongue viruses (24 at present); the vertebrate hosts in which the viruses multiply subclinically; susceptible sheep; the environment; and a range of *Culicoides* vectors capable of being infected and transmitting bluetongue virus (discussed in a later section).

These Proceedings present our current understanding of the epidemiology of bluetongue viruses in the countries represented at the Symposium. Less than 20 years ago, bluetongue viruses were not known to exist east of India. The great majority of the bluetongue viruses discovered since then are serotypes already known. In most of Asia, bluetongue is not an expanding infection and disease but rather an infection which has existed ever since cattle, buffalo and deer have been present. Bluetongue is now coming to our notice for many reasons, including changes in husbandry practices and better detection technology.

The exception to this generalisation applies in the countries to the far southeast of the Asian region, namely Papua New Guinea, Australia and the Pacific Island nations, where ruminants were not present before European colonisation. Proven *Culicoides* vectors, dependent on ruminants, have spread with the bluetongue viruses to occupy the newly created ecological niches. Bluetongue is thus emerging in

this area, to the east of Weber's line which marked a geographical barrier for many animal and plant species.

Understanding the epidemiology of bluetongue in southeast Asia, east Asia and the Pacific Islands is impossible without identifying all the virus serotypes circulating in this vast region, as infected insects are blown across national boundaries and very significant ocean gaps.

In the papers in this section, a fine start has been made to bring together the information on bluetongue in China, its neighbouring countries and the region in general. It is essential that this process continues so that, in future, control strategies can be based more fully on objective data.

One of the most interesting epidemiological observations is that, in north China, sheep and goats show higher bluetongue group antibody prevalences than cattle, in contrast to the findings in most other regions of Asia and the Pacific. Another difference is that, in Inner Mongolia, some bluetongue infection continues in winter, suggesting an additional vector system: this finding again contrasts with those in subtropical regions and other temperate areas of the world. So, through this sharing of information, first at the Symposium and now in these Proceedings, we have added yet another new element into our understanding of bluetongue epidemiology.

# A Short History of the Discovery of Bluetongue in the World

T.D. St. George\*

THE history of bluetongue in the world falls into two distinct phases. The first phase of discovery was based on the diagnosis of clinical bluetongue, mostly in outbreaks in sheep in previously bluetongue-free areas. This produced a picture of a disease which had spread from an original focus in southern Africa to encompass most of Africa, some adjacent parts of Europe, southern Asia and then to north America via ruminant imports. This view was dealt a major blow in 1977, however, when a virus isolated from an insect collected in Australia, a continent with no bluetongue disease, was identified as a bluetongue virus. Since then, large-scale surveys have linked the previously discrete areas of the world into a continuum. Disease is now accepted as only a small manifestation of the presence of this widely distributed group of closely related viruses which infect a wide range of ruminants.

## The Emergent Phase: 1900 to 1977

Bluetongue first came to notice when Merino sheep were introduced to southern Africa. The first descriptions of the disease were published there. Bluetongue was a major killer of sheep, with surviving animals suffering a loss of productivity. Much later, research in southern Africa revealed that bluetongue viruses also circulated in cattle and many wildlife species. The disease was soon also recognised in Egypt (1907), Kenya (1909) and West Africa (1927). Outside Africa, bluetongue outbreaks were diagnosed in 1943 in Cyprus, and from then until 1949 in nearby areas of Asia, such as Palestine, Turkey and Syria. In 1956, a major epidemic occurred in Merino sheep in Spain and Portugal. This caused significant alarm, especially in Australia with its vast flock of pure Merino and Merino-based breeds. Around the same time, the isolation of bluetongue virus confirmed its presence elsewhere in the world too; in the USA (1952), in Pakistan (1959) and India (1963).

In Spain, a combination of movement controls, slaughter out policies and vaccination were applied, and bluetongue appeared to have been eradicated from the country. While the sanitary measures were applied only to sheep, international movement controls or prohibitions were applied to countries where the disease in sheep had been reported, since cattle were known to be subject to subclinical infection by bluetongue viruses.

## Endemic Zone Phase

A turning point in understanding bluetongue epidemiology came in 1977, with the recognition that bluetongue virus existed without concurrent disease in Australia, several thousand kilometres away from the nearest known endemic area. Seven years previously, a system of sentinel herds, using healthy cattle as virus indicators, had been developed in Australia. This system had been established to define both the extent of arbovirus infection of ruminants and arbovirus epidemiology that was independent of disease. Once bluetongue was identified in Australia, this existing surveillance technique was used to study the virus's recent history in Australia and to search for additional serotypes of the bluetongue group. The sentinel herd approach has since been applied successfully in other countries, including several descriptions of successes in these Proceedings. Using sentinel cattle, bluetongue viruses of many serotypes have been found in northern Australia, the Caribbean and Central America, Indonesia, Malaysia, China and many other areas. Serological studies, using these newly isolated viruses as well as imported standards, has shown that the tropics, subtropics and some fringing temperate areas of the Americas, Africa, Asia and Australia are bluetongue endemic regions.

Until recently, a country was considered as infected with endemic or epidemic bluetongue according to political boundaries. However, more detailed epidemiological studies have shown that in countries where climate allows the *Culicoides* vector

---

\* 15 Tamarix Street, Chapel Hill, Queensland 4069, Australia



species to exist only in the hotter areas, there are major zones that are always free of bluetongue virus. For example, this is true of most of the European Community, Canada, southern Australia, northern Japan and parts of far north China. Full acceptance of regional freedom would usher in a new phase for trade and other livestock movements.

## How Many Bluetongue Viruses Are There?

Many years ago, apparent failures of vaccines in South Africa led to the realisation that there was more than one antigenic type of bluetongue virus. Cross-protection tests in sheep by W.O. Neitz demonstrated that 10 representative viral isolates from field cases produced solid immunity against the homologous isolate but only partial or no protection against heterologous strains.

This was the first formal classification of bluetongue viruses: based on cross protection tests, this classification established the first 10 different virus types in South Africa. Serological tests, which correlate with cross protection tests, were later used in South Africa to develop the reference system which added other newly discovered bluetongue viruses, and which now divides the bluetongue viruses into 24 serotypes. The World Reference Centre was developed at The Veterinary Research Institute in Onderstepoort, South Africa. New bluetongue viruses are submitted to the Virus Laboratory there for confirmation as an existing type or as a candidate new serotype.

It is well established that bluetongue viruses of the same or separate serotypes can exchange genetic information during dual infections of hosts without affecting their serotypes. The eventual number of serotypes will probably not be much greater than the 24, as the vast regions recently shown to be endemic have usually yielded viruses that fit into the already established serotype classification. Biochemistry and topotyping have produced new parameters for measuring genetic diversity and will, in time, lead to more understanding of regional evolution of the viral complex, but the system of serotypes, based on neutralisation tests, remain the presently accepted scheme of classification.

## Vectors

Initial studies on *Culicoides imicola* in South Africa incriminated this species, and the *Culicoides* genus of biting midges, as a bluetongue vector. The number of *Culicoides* species now proven as vectors is limited to five well studied species in Africa, Australia and North America. However, bluetongue viruses have been isolated from six more *Culicoides* species and

there is experimental evidence that others can support virus replication. The list of potential vector species is longer still, but there are insufficient resources to test all *Culicoides* species feeding on ruminants for a capacity to transmit bluetongue virus. Indeed, there is strong epidemiological evidence that not all *Culicoides* species which do feed on cattle, buffalo, sheep and goats, are capable of being infected with, and/or transmitting, the viruses.

In practical terms, the northern and southern boundaries of epidemic bluetongue areas in northern Africa, southern Europe, North and South America, Japan, Australia and the Pacific islands are reasonably known to be linked to the distribution of a very few *Culicoides* species. For several of these, little is yet known of important aspects of their biology, such as their breeding sites and larval development. The fluctuations in *Culicoides* populations, caused by season, altitude, winds, rainfall and availability of vertebrate hosts for blood meals, are fundamental in their affects on the epidemiology of bluetongue disease, but are reasonably understood for only a few species.

## Control

Bluetongue vaccines evolved to make sheep farming possible in southern Africa in the early part of this century. The use of vaccines has thus been largely targeted at preventing clinical disease in South Africa, with the other major area of vaccine use being the USA. The advantages and disadvantages of the various vaccines attenuated live, killed and inactivated and subunit vaccines have been explored in these Proceedings. Vaccines have not been applied, in an attempt to control virus spread, to those vertebrate species (buffalo, cattle and wild ruminants) in which bluetongue virus multiply but do not cause any clinical signs.

Until recently, quarantine and movement controls were applied rigorously to prevent the spread of bluetongue, as it appeared to be a world-threatening 'emerging disease' being carried from continent to continent by the trade of permanently infected ruminants. Although many of these restrictions remain in place throughout the world, evidence presented in these Proceedings suggest such controls are not necessarily rational. Indeed, there is no evidence that the present distribution of bluetongue viruses has been influenced by these historical actions.

## Coordinating Research

The publication of field and research information on bluetongue virus and its vectors, including papers presented at many scientific meetings, has helped the spread of information around the world.

However, effective coordination has been achieved only relatively recently by means of specific symposia:

- Bluetongue and related orbiviruses, Asilomar, California, USA, 16–20 January 1984 (Proceedings edited by T.L. Barber, M.M. Jochim and B.I. Osburn)
  - Symposium on bluetongue, African horse sickness and related orbiviruses, Paris, France, 17–21 June 1991 (Proceedings edited by T.E. Walton and B.I. Osburn)
  - First Southeast Asia and Pacific Regional Bluetongue Symposium, Kunming, People's Republic of China, 22–24 August 1995 (these Proceedings)
- Publication of the proceedings of these meetings, in English and in Chinese, will provide further information on the history of bluetongue. Future meetings will lead to still more knowledge of bluetongue's complexities.

## Bibliography

- Barber, T.L., Jochim, M.S. and Osburn, B.I. (ed). Bluetongue and related orbiviruses. Progress in Clinical and Biological Research, vol. 178, Alan R. Liss Inc., New York.
- Gibbs, E.P. and Greiner, E.C. 1988. Bluetongue and epizootic hemorrhagic disease. In: Monath, T.P., ed., The arboviruses: epidemiology and ecology, vol. II. CRC Press, Boca Raton, Florida, 39–70.
- Howell, P.G. 1979. The epidemiology of bluetongue in South Africa. In: St. George, T.D. and French, E.L., ed., Arbovirus research in Australia. Proceedings 2nd Symposium. CSIRO/Queensland Institute of Medical Research, Brisbane, 3–13.
- Sellers, R.F. 1981. Bluetongue. In: Gibbs, E.P.J., ed., Virus diseases of food animals. Academic Press, London, 567–584.
- Verwoerd, D.W. and Erasmus, B.J. 1994. Bluetongue. In: Coetzer, A.W., Thomson, G.R. and Tustin, R.C., ed., Infectious diseases of livestock. Oxford University Press, Cape Town, 442–459.
- Walton, T.E. and Osburn, B.J. ed. 1992. Bluetongue, African horse sickness and related orbiviruses. Proceedings 2nd International Symposium, CRC Press, Boca Raton.

# The Global Distribution of Bluetongue

R.A. Hawkes\*

## *Abstract*

Bluetongue virus (BLU), earlier thought to be an emergent virus originating in the African region, is now known to be endemic in most tropical regions of the globe, with sporadic incursions into subtropical and temperate regions. The 24 serotypes of the virus are not uniformly distributed throughout the globe, so their distribution has implications for immunisation programs and other aspects of trade in livestock. This paper summarises the known data on the present and past global distribution of bluetongue virus and its serotypes, and briefly discusses the possible factors associated with this distribution.

BLUETONGUE virus (BLU) has the distinction of being the first of the arthropod-borne viruses to be isolated in the laboratory (Karabatsos 1985). For some time bluetongue was considered to be a virus confined to Africa, its continent of initial isolation. However, the more widespread distribution of this virus throughout the world was later acknowledged, and the multiplicity of its serotypes recognised. At present, bluetongue viruses constitute a serogroup with 24 members: these 24 serotypes are differentially present, endemically or transiently, over most of the tropical and subtropical parts of the globe.

The purpose of this review is to present the current and past distribution patterns of BLU serotypes throughout the world. The subject is interesting scientifically and of some importance economically. From the scientific viewpoint, it is apparent that the ability of bluetongue viruses to persist permanently or transiently in a given area is largely dependent on the presence of sufficient populations of the appropriate vectors and hosts. This presence, in turn, depends on climatic variables such as temperature, altitude, moisture availability and wind patterns, as well as on other variables such as land-use, livestock transfer and husbandry practices. Why certain serotypes are found in different countries, but sometimes only in certain parts of such countries, are less well understood.

The distribution of serotypes also has economic implications. Serotypes are delineated by their inability to show significant reciprocal cross-neutralisation

with other BLU isolates in cell culture neutralisation tests. This classification is correlated with *in vivo* cross-protection. Given the lack of significant cross-protection between different serotypes, logic dictates that nations will have a cautious attitude towards importation of potentially infected ruminants from countries possessing exotic serotypes. In addition, the range of serotypes actually or potentially present in a country will influence vaccination policies, where such are practiced.

## **Limitations of the Data**

Extensive surveys have shown that BLU exists epidemically in most parts of the tropics and subtropics where there are sufficient populations of the appropriate vector species and mammalian (ruminant) hosts (Gibbs and Greiner 1994). At distances further from the equator, the virus tends to occur intermittently, with incursions dependent on the variables mentioned above. In certain countries it is not possible to be sure whether the available data represent a truly epidemic situation, or whether annual reintroduction of the virus from nearby countries is occurring. Before describing the distribution of the serotypes themselves, it is important to discuss the limitations of the existing data.

## **Imprecision**

Where the existence of BLU serotypes is based on virus isolation and identification, a high degree of reliability can be placed on the data. However, if reporting has been based solely on serological testing, less certainty is warranted. Where the agar gel

---

\* Virology Laboratory, Elizabeth MacArthur Agricultural Institute, PMB 8, Camden, New South Wales 2570, Australia.

immunodiffusion (AGID) test has been used, no indication of serotype is possible, because of the group-reactive nature of the test. Furthermore, the results of such surveys are confounded both by insensitivity, leading to an under-estimate of prevalence, and by excessive cross-reactivity with other orbivirus groups, leading to an over-estimate of prevalence. Where the competitive enzyme linked immunosorbent assay (cELISA) with BLU group-reactive monoclonal antibody has been used, the data are representative of genuine BLU infection prevalence but give no indication of serotype.

In those cases where serological testing has been based on virus neutralisation (VN) tests in cell culture, there is a much better prospect of establishing genuine serotype presence. Caution must be exercised even here, however, since a limited but definite cross-reactivity exists between members of different serotypes of the BLU serogroup, even with the VN test. Cross-reactive VN antibodies within an individual animal are accentuated even further when multiple BLU infections occur (MacLachlan 1994). Furthermore, different studies have often employed variations in methodologies (for example, plaque inhibition rather than plaque neutralisation), and used different criteria for evaluation.

For these reasons, the accompanying tables show serotype presence that has been established by virus isolation separately to that established by type-specific serology. Where surveys using only AGID have been carried out in a country, this is noted in the text.

### **Incompleteness**

The data presented here are incomplete for at least two reasons. First, sampling in many countries has been incomplete or even absent. Second, there has sometimes been a reluctance on the part of governments to release data, for trade or other considerations. Indeed, serological evidence supporting virus presence has been formally published for several countries currently registered in the World Animal Health Reports of the Office International des Epizooties (OIE) as never having reported the disease. For these reasons, if a country is not mentioned in the accompanying data, this does not necessarily imply the absence of bluetongue virus.

Freedom from clinical disease is not a good indication of absence of the bluetongue virus, since it may be present in species which rarely exhibit symptoms. However, it is a reasonable assumption that countries at latitudes above those able to sustain vector species are indeed free of bluetongue.

### **Intra-national variability**

Bluetongue viruses are seldom present in equal intensity throughout the whole of a country because of within-country differences in climatic and other

factors. Sometimes this differential presence is reflected in the literature, in that the locations of blood and vector samplings are given, but often it is not. This should be kept in mind when interpreting data from countries that embrace, within their borders, large variability in latitude, altitude and precipitation patterns.

### **Instability**

Even in areas where bluetongue viruses are endemic, the predominant serotypes are not always the same ones in successive years. Even in surveillance studies employing consistent methodology, viruses thought to be genuinely persistent in an area may sink to undetectable levels of prevalence from time to time, only to emerge in succeeding years (Gard and Melville 1992). The reasons for this cycling are largely obscure. It is beyond the scope of this review to present these year-by-year changes in serotype for parts of the world where bluetongue is endemic.

In areas where the virus occurs transiently, disease tends to occur in immunologically naive populations of sheep. In such areas, it is not always the same serotype which is involved in successive appearances. For these 'epidemic' areas, an attempt has been made to specify the serotype in each section.

## **Global Distribution of Serotypes**

The following information, summarised graphically in Figure 1, is presented under the continent/country classification adopted by the annual World Animal Health reports of the OIE. The designation 'disease never reported' is based on the OIE's latest available report (Anon. 1993), modified where reports in the scientific literature have indicated the presence of BLU antibodies or BLU isolations.

### **Africa**

Of the 24 known BLU serotypes, only BLU23 has not been shown to be present in Africa (although only serological evidence exists for BLU17, 20 and 21). Most BLU serotypes are probably endemic over most of the continent, with the possible exception of the north western corner (Gibbs and Greiner 1994). Of the 47 mainland and island African countries listed in the OIE reports, only seven (Algeria, Libya, Tunisia, Guinea Bissau, Ethiopia, Comoros and Madagascar) have either never reported the disease or never shown serological evidence of virus presence (Anon. 1993). Fifteen countries have clinical or serological evidence for virus presence, but no data on serotypes: Burkina Faso (Anon. 1993), Ivory Coast (Taylor and McCausland 1976), Ghana (Taylor and McCausland 1976), Guinea (Konstantinov 1990), Mali (Maiga and

Sarr 1992), Niger (Weitzman et al. 1991), Chad (Taylor and McCausland 1976), Zaire (Anon. 1992), Tanzania (Hamblin et al. 1990), Somalia (Hussein-Hag et al. 1985), Botswana (Simpson 1979), Mozambique (Ferreira and Rosinha 1986), and Zambia (Ghirotti et al. 1991). Some countries have presented no data but BLU is probably present in most of these (Ozawa 1985). Eleven African countries (OIE classification) have serotype-specific data (Table 1).

The distribution of serotypes shows no particular pattern throughout the continent, except that, so far as can be determined from the uneven intensity of sampling,

the multiplicity of serotypes diminishes in the north, as distance from the equator increases. Both serotypes from Reunion were identified during an investigation of a single outbreak occurring on the island in 1979.

### The Americas

The BLU status in the United States of America has been well studied for many years, and the situation in Central America and the Caribbean studied increasingly in recent times. On the South American continent, studies have been more restricted and the southern limits of the virus have yet to be determined.

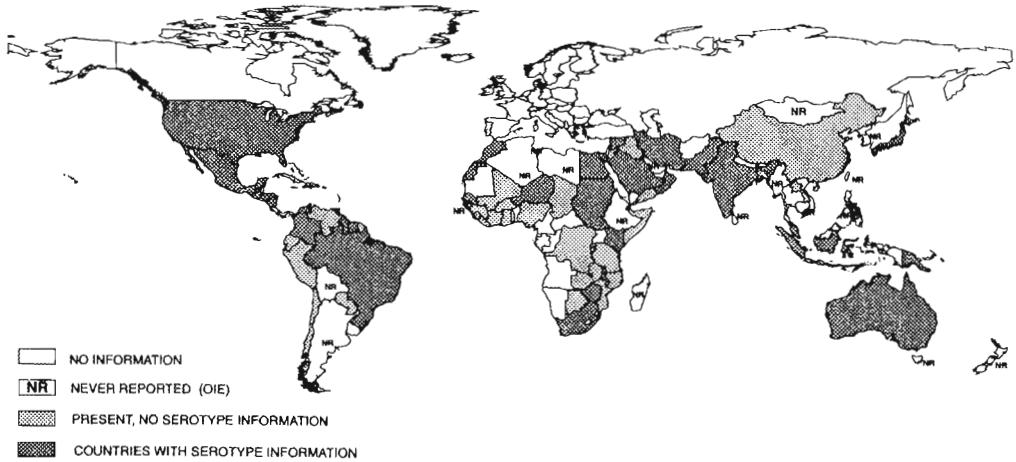

Figure 1. Global distribution of bluetongue.

Table 1. Bluetongue (BLU) serotypes in Africa.

OIE zone	Country	BLU serotypes identified by:		Reference
		virus isolation	serology (additional)	
1	Egypt	1, 12, 16	4, 10	Barsoum 1992, Hafez and Ozawa 1981
	Morocco		10	Tomori et al. 1992
2	Cameroon	1, 4, 5, 12, 14, 16		Ekue et al. 1985a, 1985b
	Nigeria	1, 2, 3, 5-8, 10, 11, 12, 16, 22	4, 9, 13, 20	Sellers 1984, Herniman et al. 1983, Lee et al. 1974
	Senegal		6, 14	Lefevre and Taylor 1983
4	Kenya	1, 2, 3, 4, 8, 13, +3 untyped	? 9 others	Sellers 1984, Davies 1978
	Sudan	1, 2, 4, 5, 16	6-10, 14, 17, 20, 21, 22	Mohammed and Mellors 1990, Abu-Elzein 1985, Elfatih et al. 1987
5	Malawi		1, 2, 3, 5, 8, 10, 14, 15, 20, 21, 22	Haresnape et al. 1988
	South Africa	1-15, 18, 19, 24		Sellers 1984, Nevill et al. 1992
	Zimbabwe	11		Blackburn et al. 1985
	Reunion	2	4	Barrem et al. 1985

Of the 37 American countries or island groups listed by OIE, five have presented no data and seven (Argentina, Bermuda, Bolivia, Cuba, Grenada, Haiti and Uruguay) have never reported the disease or positive serology (Anon. 1993). The OIE lists a further five countries (Belize, Paraguay, Venezuela, Montserrat and St. Vincents and the Grenadines) as having clinical or serological evidence for the virus (Anon. 1993). Chile (Tamayo et al. 1983), Ecuador (Lopez et al. 1985), French Guiana (Lancelot et al. 1989) and Peru (Rosadio et al. 1984) have untyped virus or group serology only. Other countries have serotype-specific information (Table 2).

The Canadian data represent incursions of BLU11 into the Okanagan Valley in southwestern Canada in 1975 and 1987/88. In the USA the virus is epidemic in the southern and western States (Gibbs and Greiner 1994). BLU10, 13, 14 and 17 may have evolved together in the USA over a long period of time but BLU2, which is apparently confined to the southern States, may be a recent introduction from elsewhere

(Heidner et al. 1992). To date, the only serotype in common between those on the continent (Mexico and northwards) and those in the other parts of the Americas is BLU17: with respect to bluetongue, the two regions appear to be distinct ecological zones (Gibbs and Greiner 1994).

### Asia

Of the 35 Asian countries listed by the OIE, nine have provided no data on BLU prevalence and ten (Bahrain, Hong Kong, Korea, Mongolia, Sri Lanka, Myanmar, Philippines, Singapore, Taipei China and Vietnam) have reported the absence of past disease or any positive serology (Anon. 1993). Nevertheless, some of these countries probably have one or more BLU serotypes. Five countries have reported the presence of bluetongue disease and/or positive group serology: these are Laos, People's Republic of China (Anon. 1993), Iraq (Hafez et al. 1978), Yemen (Stanley 1990), and Bangladesh (Hakim 1985). Eleven countries have serotype-specific data (Table 3).

**Table 2.** Bluetongue (BLU) serotypes in the Americas.

OIE zone	Country	BLU serotypes identified by:		References
		Virus isolation	Serology (additional)	
1	Canada	11 (1975, 1977/78)		Dulac et al. 1992, Shapiro et al. 1987, Thomas et al. 1982
	Mexico	10, 11, 13, 17		Stott et al. 1989
	USA	2, 10, 11, 13, 17		Gibbs and Greiner 1994, Heidner et al. 1992
	Costa Rica	1, 3, 6		Mo et al. 1994
	El Salvador	1, 3, 6		Mo et al. 1994
	Guatemala	1, 3, 6, 17		Mo et al. 1994
	Honduras	1, 2, 6, 17		Mo et al. 1994
	Nicaragua	1, 3, 6		Mo et al. 1994
	Panama	1, 3, 6		Mo et al. 1994
	2	Barbados	1, 3	
Dominican Republic		4, 6, 8		Mo et al. 1994
Jamaica		3, 12		Mo et al. 1994
Puerto Rico		3, 4, 17		Mo et al. 1994, Shaw 1992
Trinidad and Tobago		3		Mo et al. 1994
Caribbean Islands <sup>a</sup>			1, 6, 12, 14, 17	Mo et al. 1994
3	Brazil	4		Gurgel-da-Cunha 1990, Grocock and Campbell 1982
	Colombia		1, 6, 12, 14, 17	Homan et al. 1992
	Surinam		6, 14, 17	Homan et al. 1992
	Guyana		6, 14, 17	Homan et al. 1992

<sup>a</sup> Antigua, Barbados, Grenada, Jamaica, St. Kitts, St. Lucia, Trinidad and Tobago.

**Table 3.** Bluetongue (BLU) serotypes in Asia.

OIE zone	Country	BLU serotypes identified by:		References
		Virus isolation	Serology (additional)	
1	Iran		3 (7, 20, 22)	Moakhar et al. 1988
	Israel	2, 4, 6, 10, 16		Hassan 1992, Sellers 1975
	Jordan		6 (2?, 4, 9, 13, 15)	Taylor et al. 1985, Taylor and Mellors 1994
	Oman		3, 4, 6, 14, 15, 17, 19, 20, 21, 22	Al-Busaidy and Mellors 1991, Taylor et al. 1991
	Saudi Arabia		6, 14, 17, 19, 20	Hafez and Taylor 1985
	Syria	2, 4, 6, 9, 13, 15		Taylor et al. 1985, Taylor and Mellors 1994
2	India	1, 2, 3, 4, 8, 9, 12, 16, 17, 18	5, 6, 7, 10, 11, 14, 15, 20	Uppal 1992, Kulkarni et al. 1992
	Pakistan	16		Ritter and Roy 1988
3	Indonesia	1, 7, 9, 12, 21, 23		Sendow et al. 1993
	Japan		1, 12, 20	Miura et al. 1982
	Malaysia	1, 2, 3, 9, 16, 23	5, 20, 21	Hassan 1992, Sharifah et al. 1995

**Oceania**

There is currently no evidence for the presence of BLU in Fiji, New Caledonia (St George, 1992), New Zealand (Ryan et al. 1991) or Vanuatu (Doyle 1992). Papua New Guinea apparently has at least three serotypes, thought on serological grounds to be BLU1, 21 and 23 (Gard et al. 1985, D.H. Cybinski, pers. comm.). An untyped strain of the virus has been isolated from the Solomon Islands (Doyle 1992). Eight BLU serotypes (BLU1, 3, 9, 15, 16, 20, 21 and 23) have been isolated in Australia (Doyle 1992), but the southern part of the continent is free of the virus, as is Tasmania (Sadler and Witt 1992). Six of the eight serotypes are apparently confined to the northern-most part of the continent, with only BLU1 and 21 having a wider distribution southwards (Ward 1994).

**Europe**

Of the 33 European countries submitting reports to OIE, 28 have not experienced bluetongue (Anon.

1993). The virus is thought not to be endemic within mainland Europe at present (Gibbs and Greiner 1994), with the possible exception of Turkey (Sellers 1984). Most outbreaks in Europe appear to have been introduced from elsewhere and the virus has tended to die out after epidemics. Five European countries have identified serotypes (Table 4).

**Discussion**

The global distribution of BLU serotypes can be expected to be in a state of continuous flux as climatic changes, especially those relating to temperature, rainfall and wind patterns affect the distribution of vectors and hosts. In addition, changes in land use, especially those relating to the geographical distribution of ruminants, influence the areas where new BLU serotypes can intrude and perhaps persist.

The current situation, as presented above, is subject to the limitations previously mentioned, especially

**Table 4.** Bluetongue (BLU) serotypes in Europe.

OIE zone	Country	BLU serotypes identified by:		References
		Virus isolation	Serology (additional)	
2	Cyprus	3 (pre-1965)	10, 12	Ritter and Roy 1988, Polydorou 1978
		4 (1969, 1977)		
	Greece (Lesbos, Rhodes)	4 (1979)		Papadopoulos 1992
	Portugal	10 (1957-59)		Sellers 1984
	Spain	10 (1957-60)		Sellers 1984
	Turkey	4 (1977-80)	2 (1981)	Burgu et al. 1992

the one of non-uniform sampling across the whole globe. Nevertheless, an overall global analysis, based conservatively on virus isolation alone, reveals some interesting trends which can be discussed tentatively, pending the acquisition of further data.

With reference to bluetongue, Central America (south of Mexico) is grouped with the Caribbean and South American countries (Gibbs and Greiner 1994). Using this modified OIE country classification, it is interesting to compare the distribution of serotypes in the five endemic zones (Fig. 2). Of the 24 BLU serotypes, 20 have been isolated in Africa, 16 in Asia, eight in Australia/Oceania, seven in Central/Caribbean/South America, and five in North America. (In the present discussion, Europe is best regarded as an 'incursion zone', of little significance in BLU epidemiology.) On the basis of multiplicity of serotypes, it probably remains reasonable to postulate that the original source of BLU was in Africa.

Six serotypes have been isolated only from one continent; BLU5, 14, 19, 22 and 24 from Africa, and BLU20 from Australia. Six serotypes have been isolated only from two of the OIE groupings: BLU7 and 18 have been recovered from both Africa and Asia, BLU11 and 13 have been isolated from both Africa and North America, and BLU21 and 23 have been recovered from both Asia and Australia. Ten serotypes (BLU2, 4, 6, 8, 9, 10, 12, 15, 16 and 17) have been recovered from three of the five geographical groupings. Finally, two serotypes (BLU1 and 3) are very widespread in their distribution, having been found in all continents and island groupings with the exception of northern America. At present, no serotypes have been recovered from all five geographical groupings.

Whether these trends reflect the real state of affairs, or whether they represent grossly incomplete sampling, remains for future research to determine. Progress on defining the situation in the People's Republic of China is reported in these Proceedings.

## References

Abu-Elzein, E.M.E. 1985. Bluetongue in the Sudan. *Revue Scientific and Technique, Office International des Epizooties*, 4, 795-801.

Al-Busaidy, S.M. and Mellors, P.S. 1991. Isolation and identification of arboviruses from the Sultanate of Oman. *Epidemiology and Infection*, 100, 403-413.

Anon. 1992. World animal health 1992. Office International des Epizooties, 12 rue de Prony, 75017 Paris, France.

—1993. World animal health 1993. Office International des Epizooties, 12 rue de Prony, 75017 Paris, France.

Barrem, N., Erasmus, B.J., Gautier, A., Reme, A. and Valin, R. 1985. Bluetongue, a new disease of sheep on Reunion (Indian Ocean). *Revue d'Elevage et de Medecine Veterinaire des Pays Tropicaux*, 38, 16-21.

Barsoum, G.W. 1992. Bluetongue and African horse sickness situation in Egypt. In: Walton, T.E. and Osburn, B.I., ed., *Bluetongue, African horse sickness and related orbiviruses. Proceedings 2nd International Symposium*. CRC Press, Boca Raton, 42-43.

Blackburn, N.K., Searle, L. and Phelps, R.J. 1985. Viruses isolated from *Culicoides* (Diptera: Ceratopogonidae) caught at the veterinary research farm, Mazowe, Zimbabwe. *Journal of the Entomological Society of Southern Africa*, 48, 331-336.

Burgu, I., Urman, H.K., Akca, Y., Yonguc, A., Mellors, P.W. and Hamblin, C. 1992. Serologic survey and vector surveillance for bluetongue in southern Turkey. In: Walton, T.E. and Osburn, B.I., ed., *Bluetongue, African horse sickness and related orbiviruses. Proceedings 2nd International Symposium*. CRC Press, Boca Raton, 168-174.

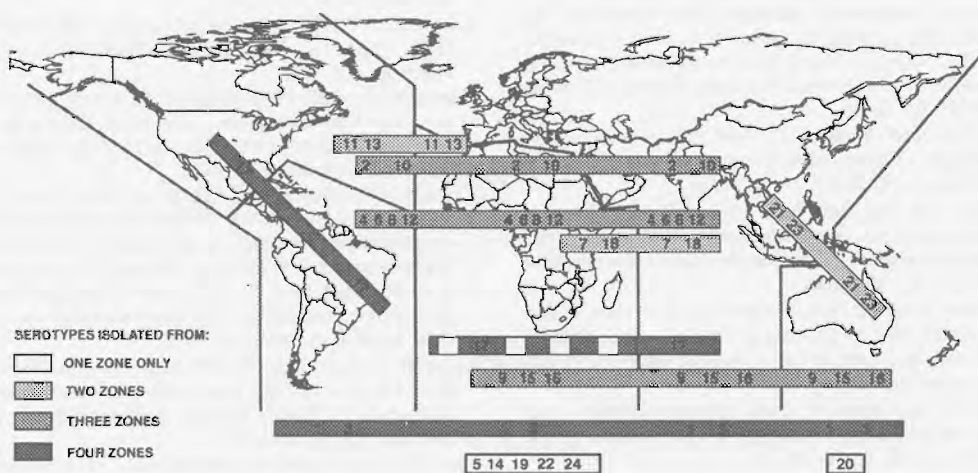

Figure 2. Global distribution of bluetongue in the OIE zones.



- Davies, F.G. 1978. Bluetongue studies with sentinel cattle in Kenya. *Journal of Hygiene*, 80, 197-204.
- Doyle, K.A. 1992. An overview and perspective on orbivirus disease prevalence and occurrence of vectors in Australia and Oceania. In: Walton, T.E. and Osburn, B.I., ed., *Bluetongue, African horse sickness and related orbiviruses*. Proceedings 2nd International Symposium. CRC Press, Boca Raton, 44-57.
- Dulac, G.C., Sterritt, W.G., Dubuc, C., Afshar, A., Myers, D.J., Taylor, E.A., Jamieson, B.R. and Martin, M.W. 1992. Incursions of orbiviruses in Canada and their serologic monitoring in the native animal population between 1962 and 1991. In: Walton, T.E. and Osburn, B.I., ed., *Bluetongue, African horse sickness and related orbiviruses*. Proceedings 2nd International Symposium. CRC Press, Boca Raton, 120-127.
- Ekue, F.N., Nfi, A.N., Tsangue, P., Taylor, W.P. and Gumm, I.D. 1985a. Bluetongue in exotic sheep in Cameroon. *Tropical Animal Health and Production*, 17, 187-188.
- 1985b. Prevalence of bluetongue virus antibodies in ruminants in Cameroon. *Tropical Animal Health and Production*, 17, 189.
- Elfatih, M., Mohammed, H. and Taylor, W.P. 1987. Infection with bluetongue and related orbiviruses in the Sudan detected by the study of sentinel calf herds. *Epidemiology and Infection*, 99, 533-545.
- Ferriera, M.L. and Rosinha, A. 1986. Preliminary analysis of data from 'Operation Buffalo' (*Syncerus caffer*) in Mozambique. *Repositorio de Trabalhos do Laboratorio nacional de Investigacao Veterinaria*, 18, 83, 85-100.
- Gard, G.P. and Melville, L.F. 1992. Results of a decade's monitoring for orbiviruses in sentinel cattle pastured in an area of regular arbovirus activity in Northern Australia. In: Walton, T.E. and Osburn, B.I., ed., *Bluetongue, African horse sickness and related orbiviruses*. Proceedings 2nd International Symposium. CRC Press, Boca Raton, 85-89.
- Gard, G.P., Shorthose, J.E., Cybinski, D.H. and Zakrzewski, H. 1985. The isolation from cattle of 2 bluetongue viruses new to Australia. *Australian Veterinary Journal*, 62, 203.
- Ghirotti, M., Semproni, G., Meneghi, D-de, Mungaba, F.N., Nannini, D., Calzetta, G., Paganico, G. and De-Meneghi, D. 1991. Sero-prevalences of selected cattle diseases in the Kafue flats of Zambia. *Veterinary Research Communications*, 15, 25-36.
- Gibbs, E.P.J. and Greiner, E.C. 1994. The epidemiology of bluetongue. *Comparative Immunology, Microbiology and Infectious Diseases*, 17, 207-220.
- Grocock, C.M. and Campbell, C.H. 1982. Antibodies to bluetongue viruses in animals imported into United States zoological gardens. *Canadian Journal of Comparative Medicine*, 46, 160-164.
- Gurgel-da-Cunha, R. 1990. Neutralizing antibodies for different serotypes of bluetongue virus in serum samples from cattle and goats in Brazil. *Revista Brasileira Medicina Veterinaria*, 12, 3-7.
- Hafez, S.M. and Ozawa, Y. 1981. Antigenic types of bluetongue virus prevalent in Egypt. *Tropical Animal Health and Production*, 13, 49-54.
- Hafez, S.M., Pollis, E.G. and Mustafa, S.A. 1978. Serological evidence of the occurrence of bluetongue in Iraq. *Tropical Animal Health and Production*, 10, 95-98.
- Hafez, S.M. and Taylor, W.P. 1985. Serotypes of bluetongue virus present in Saudi Arabia. In: Barber, T.C., Jochim, M.S. and Osburn, B.I. ed., *Bluetongue and related orbiviruses*. Progress in Clinical and Biological Research, vol. 178, Alan R. Liss Inc, New York, 531-537.
- Hakim, M.D.A. 1985. Bangladesh. In: Della-Porta, A.J., ed., *Veterinary viral diseases, their significance in South-East Asia and the Western Pacific*. Academic Press, Sydney, 168-173.
- Hamblin, C., Anderson, E.C., Jago, M., Mlengeya, T. and Hirji, K. 1990. Antibodies to some pathogenic agents in free-living wild species in Tanzania. *Epidemiology and Infection*, 105, 585-594.
- Haresnape, J.M., Taylor, W.P. and Lungu, S.A.M. 1988. The epidemiology of bluetongue in Malawi. *Epidemiology and Infection*, 100, 493-499.
- Hassan, S. 1992. Status of bluetongue in the Middle East and Asia. In: Walton, T.E. and Osburn, B.I., ed., *Bluetongue, African horse sickness and related orbiviruses*. Proceedings 2nd International Symposium. CRC Press, Boca Raton, 38-41.
- Heidner, H.W., Izzi, L.G., Osburn, B.I. and MacLachlan, N.J. 1992. Genetic variation and evolutionary relationships among bluetongue viruses endemic in the United States. *Virus Research*, 21, 91-109.
- Hemiman, K.A.J., Boorman, J.P.T. and Taylor, W.P. 1983. Bluetongue virus in a Nigerian dairy cattle herd. 1. Serological studies and correlation of virus activity to vector population. *Journal of Hygiene*, 90, 177-193.
- Homan, E.J., Gibbs, E.P.J., Walker, J.S., Walton, T.E., Yuill, T.M., Gonzalez, J., Garreto, G.H. and Greiner, E.C. 1992. Central American and Caribbean regional bluetongue epidemiologic studies: antecedents and geographic review. In: Walton, T.E. and Osburn, B.I., ed., *Bluetongue, African horse sickness and related orbiviruses*. Proceedings 2nd International Symposium. CRC Press, Boca Raton, 99-105.
- Hussein-Hag, A., Gallo, C., Caracappa, S. and Vesco, G. 1985. Serological survey for antibodies to abortion-producing agents in zebu in Somalia. *Atti della Societa Italiana de Buoiatria*, 17, 573-575.
- Karabatsos, N. 1985. International catalogue of arboviruses 1985. American Society of Tropical Medicine and Hygiene.
- Konstantinov, O.K. 1990. Ticks of the family Ixodidae as arbovirus reservoirs in the Republic of Guinea. II. The arboviruses. *Revue d'Elevage et de Medecine Veterinaire des Pays Tropicaux*, 43, 15-22.
- Kulkarni, D.D., Bannalikal, A.S., Karpe, M.B., Gujar, M.B. and Kulkarni, M.N. 1992. Epidemiological observations on bluetongue in sheep in the Marathwada region of Maharashtra State in India. In: Walton, T.E. and Osburn, B.I., ed., *Bluetongue, African horse sickness and related orbiviruses*. Proceedings 2nd International Symposium. CRC Press, Boca Raton, 193-196.
- Lancelot, R., Calvez, D., Waller, J., Dremer, M., Sanite, L. and Lefevre, P.C. 1989. Epidemiological observations on bluetongue in French Guiana. *Epidemiologie et Sante Animale*, 15, 103-116.
- Lee, V.H., Causey, O.R. and Moore, D.L. 1974. Bluetongue and related viruses in Ibadan, Nigeria: isolation and preliminary identification of viruses. *American Journal of Veterinary Research*, 35, 1105-1108.

- Lefevre, P.C. and Taylor, W.P. 1983. Epidemiological situation of bluetongue in Senegal. *Revue d'Elevage et de Medecine Veterinaire des Pays Tropicaux*, 36, 241-245.
- Lopez, W.A., Nicoletti, P. and Gibbs, E.P.J. 1985. Antibody to bluetongue virus in cattle in Ecuador. *Tropical Animal Health and Production*, 17, 82.
- MacLachlan, N.J. 1994. The pathogenesis and immunology of bluetongue infection of ruminants. *Comparative Immunology, Microbiology and Infectious Diseases*, 17, 197-206.
- Maiga, S. and Sarr, J. 1992. Epidemiological survey of the main respiratory viruses of small ruminants in Mali. *Revue d'Elevage et de Medecine Veterinaire des Pays Tropicaux*, 45, 15-17.
- Miura, Y., Inaba, Y., Tsuda, T., Tokuhisa, S., Sato, K. and Akashi, H. 1982. Seroepizootiological survey on bluetongue virus infection in Japan. *National Institute of Animal Health Quarterly (Japan)*, 22, 145-158.
- Mo, C.L., Thompson, L.H., Homan, E.J., Oviedo, M.T., Greiner, E.C., Gonzalez, J. and Saenz, M.F. 1994. Bluetongue virus isolations from vectors and ruminants in Central America and the Caribbean. *American Journal of Veterinary Research*, 55, 211-215.
- Moakhar, R.K., Taylor, W.P., Ghaboussi, B. and Hessami, M. 1988. Serological survey of sheep in Iran for type specific antibody to bluetongue virus. *Archives de l'Institut Razi*, 38/39, 92-99.
- Mohammed, M.E.H. and Mellors, P.S. 1990. Further studies on bluetongue and bluetongue-related orbiviruses in the Sudan. *Epidemiology and Infection*, 105 (3), 619-632.
- Nevill, E.M., Erasmus, B.J. and Venter, C.J. 1992. A six-year study of viruses associated with *Culicoides* biting midges throughout South Africa (Diptera: Ceratopogonidae). In: Walton, T.E. and Osburn, B.I., ed., *Bluetongue, African horse sickness and related orbiviruses*. Proceedings 2nd International Symposium. CRC Press, Boca Raton, 314-319.
- Ozawa, Y. 1985. Bluetongue and related orbiviruses: overview of the world situation. In: Barber, T.C., Jochim, M.S. and Osburn, B.I. ed., *Bluetongue and related orbiviruses*. Progress in Clinical and Biological Research, vol. 178, Alan R. Liss Inc, New York, 13-20.
- Papadopoulos, O. 1992. Bluetongue and epizootic hemorrhagic disease in Europe and the European community. In: Walton, T.E. and Osburn, B.I., ed., *Bluetongue, African horse sickness and related orbiviruses*. Proceedings 2nd International Symposium. CRC Press, Boca Raton, 34-37.
- Polydorou, K. 1978. The 1977 outbreak of bluetongue in Cyprus. *Tropical Animal Health and Production*, 10, 229-232.
- Ritter, D.G. and Roy, P. 1988. Genetic relationships of bluetongue virus serotypes isolated from different parts of the world. *Virus Research*, 11, 33-47.
- Rosadio, R.H., Evermann, J.F. and DeMartini, J.C. 1984. A preliminary serological survey of viral antibodies in Peruvian sheep. *Veterinary Microbiology*, 10, 91-96.
- Ryan, T.J., Frampton, E.R., Motha, M.X.J. and Horner, G.W. 1991. Arbovirus and arbovirus vector surveillance in New Zealand. *Surveillance*, Wellington, 18, 24-26.
- Sadler, E.C. and Witt, D.J. 1992. Survey of cattle in Tasmania for antibody to bluetongue virus. *Australian Veterinary Journal*, 69, 262.
- Sellers, R.F. 1975. Bluetongue in Cyprus. Symposium on Bluetongue, Adelaide, May 1974. *Australian Veterinary Journal*, 51, 198-203.
- 1984. Bluetongue in Africa, the Mediterranean region and Near East—disease, virus and vectors. *Preventive Veterinary Medicine*, 2, 371-378.
- Sendow, I., Daniels, P.W., Soleha, E., Erasmus, B., Sukarsih and Ronohardjo, P. 1993. Isolation of bluetongue virus serotypes new to Indonesia from sentinel cattle in West Java. *The Veterinary Record*, 133, 166-168.
- Shapiro, J.L., Wiegers, A., Dulac, G.C., Bouffard, A., Afshar, A., Myers, D.J., Dubuc, C., Martin, M.W. and Koller, M. 1987. A survey of cattle for antibodies against bluetongue and epizootic hemorrhagic disease of deer viruses in British Columbia and southwestern Alberta in 1987. *Canadian Journal of Veterinary Research*, 55, 203-204.
- Sharifah, S.H., Ali, M.A., Gard, G.P. and Polkinghorne, I.G. 1995. Isolation of multiple serotypes of bluetongue virus from sentinel livestock in Malaysia. *Tropical Animal Health and Production*, 27, 37-42.
- Shaw, J. 1992. Sentinel herd study of bluetongue in Puerto Rico. Preliminary results, January 1991. *Annals of the New York Academy of Sciences*, 653, 194-196.
- Simpson, V.R. 1979. Bluetongue antibody in Botswana's domestic and game animals. *Tropical Animal Health and Production*, 11, 43-49.
- St. George, T.D. 1992. Occupation of an ecological niche in Pacific Ocean countries by bluetongue and related viruses. In: Walton, T.E. and Osburn, B.I., ed., *Bluetongue, African horse sickness and related orbiviruses*. Proceedings 2nd International Symposium. CRC Press, Boca Raton, 76-84.
- Stanley, M.J. 1990. Prevalence of bluetongue precipitating antibodies in domesticated animals in Yemen Arab Republic. *Tropical Animal Health and Production*, 22, 163-164.
- Stott, J.L., Blanchard-Channell, M., Osburn, B.I., Riemann, H.P. and Obeso, R.C. 1989. Serologic and virologic evidence of bluetongue virus infection in cattle and sheep in Mexico. *American Journal of Veterinary Research*, 50, 335-340.
- Tamayo, R., Alonso, O. and Schoebitz, R. 1983. Antibodies to bluetongue virus in cattle—first report from Chile. *Archivos de Medicina Veterinaria, Chile*, 15, 49.
- Taylor, W.P., Al-Busaidy, S.M. and Mellors, P.S. 1991. Bluetongue in the Sultanate of Oman, a preliminary epidemiological study. *Epidemiology and Infection*, 107, 87-97.
- Taylor, W.P. and McCausland, A. 1976. Studies with bluetongue virus in Nigeria. *Tropical Animal Health and Production*, 8, 69-173.
- Taylor, W.P. and Mellors, P.S. 1994. Distribution of bluetongue virus in Turkey, 1978-81. *Epidemiology and Infection*, 112, 623-633.
- Taylor, W.P., Sellers, R.F., Gumm, I.D., Herniman, K.A.J. and Owen, I. 1985. Bluetongue epidemiology in the Middle East. In: Barber, T.C., Jochim, M.S. and Osburn, B.I. ed., *Bluetongue and related orbiviruses*. Progress in Clinical and Biological Research, vol. 178, Alan R. Liss Inc., New York, 527-530.

- Thomas, F.C., Skinner, D.J. and Samagh, B.S. 1982. Evidence for bluetongue virus in Canada: 1976–1979. *Canadian Journal of Comparative Medicine*, 46, 350–353.
- Tomori, O., Baba, S., Adu, F. and Adeniji, J. 1992. An overview and perspective on orbivirus disease prevalence and occurrence of vectors in Africa. In: Walton, T.E. and Osburn, B.I., ed., *Bluetongue, African horse sickness and related orbiviruses*. Proceedings 2nd International Symposium. CRC Press, Boca Raton, 23–33.
- Uppal, P.K. 1992. Present position of African horse sickness and bluetongue in India. In: Walton, T.E. and Osburn, B.I., ed., *Bluetongue, African horse sickness and related orbiviruses*. Proceedings 2nd International Symposium. CRC Press, Boca Raton, 175–180.
- Ward, M.P. 1994. The epidemiology of bluetongue virus in Australia a review. *Australian Veterinary Journal*, 71, 3–7.
- Weitzman, G.L., Stem, E.C., Gilfillan, R.S. and Lindemayer, J.M. 1991. Preliminary serological survey for bluetongue and toxoplasmosis in sheep in Niger. *Tropical Animal Health and Production*, 23, 258.

# Bluetongue Viruses in India: a Review

D. Sreenivasulu\*, M.V. Subba Rao\* and G.P. Gard†

## Abstract

After the first outbreak in 1964, bluetongue has become endemic even in native Indian sheep. Antibodies were found by AGID in 45.56% of native sheep and goats respectively, with 5.25% more positives detected by cELISA. Initially, the morbidity among native sheep was 80%. There is no evidence of clinical bluetongue in cattle and goats despite a high incidence of seroconversion. The pattern of disease in native sheep was studied during 1983–1994. Morbidity was cyclical and ranged from 2% to 27.7%, while the rate of case fatalities ranged from 1% to 27.6%. Bluetongue occurred in India between June and October, after the onset of rains. In Andhra Pradesh (south India), the disease occurred during September to October when the temperature was moderate, between 25° to 32°C. Several bluetongue virus (BLU) serotypes have been identified among exotic and crossbred sheep and, recently, BLU has been isolated and identified from native sheep. The clinical nature and severity in natural and experimental bluetongue infection among native sheep differed slightly from that among exotic and crossbreeds.

BLUETONGUE has become one of the important diseases of sheep in India, being reported annually from the states of Andhra Pradesh, Tamil Nadu, Karnataka and Maharashtra. The disease is considered to be a serious problem in native sheep in southern India.

## Clinical Signs and Symptoms

Exotic breeds of sheep, like Corriedale, Merino and Rambouillet, exhibit classical symptoms of bluetongue (Uppal and Vasudevan 1980; Vasudevan 1982; Jain et al. 1986) and a similar clinical picture was noticed in crossbreeds. Swollen ears hanging while the sheep were grazing in the hot sun was usually the first symptom observed by shepherds, with affected sheep trying to seek shade.

---

\* Department of Microbiology, College of Veterinary Science, Andhra Pradesh Agricultural University, Tirupati 517 502, India.

† Bureau of Resources Science, Department of Primary Industries and Energy, PO Box E11, Queen Victoria Terrace, Parkes, ACT 2601, Australia.

Native sheep, however, showed less conspicuous swelling of the face and lips. The mucocutaneous borders of lips do appear to be very sensitive to touch and bleed easily upon handling, but cyanosis of the tongue and reddening of the coronary band is not evident in many cases. The inconspicuousness of these signs can mainly be attributed to the general appearance of the native sheep, as some of the breeds have pigmented skin, mucous membranes and tongue.

## Morbidity and Mortality

In 1961, bluetongue outbreaks were recorded among native sheep and goats in Maharashtra, with a morbidity of 16 to 20% and a case fatality of 20% (Sapre 1964). During 1981, bluetongue was widespread in southern states. In Maharashtra, morbidity and mortality rates were 9.7% and 1.1% respectively, with a case fatality rate of 11.5% (Harbola et al. 1982). During subsequent outbreaks, the severity of the disease increased with an overall morbidity of 32%, mortality of 8% and case fatality of 25% (Kulkarni et al. 1992).

Bluetongue epidemics occurring in Andhra Pradesh in 1981 were more severe than in Maharashtra, with

morbidity and mortality rates of 30% and 6.5% respectively. In 1983 bluetongue outbreaks were reported from all over Andhra Pradesh with a case fatality rate of 21.9%. The increased case fatality rates could be ascribed to an increase in virus virulence. Bluetongue was subsequently noticed regularly in this state with case fatality rates ranging from 2.4% to 22.2%. A cyclical pattern in the disease was observed with variations in severity of infection (Table 1). The severity of bluetongue was also greater in Karnataka during the 1981 epidemic (Srinivas et al. 1982). From 1986, a total of 77 outbreaks were reported from Tamil Nadu over a period of five years, with morbidity rates from 3.3% to 22.8% and mortality rates from 0% to 6.1% (Saravanabava 1992).

In north India, the first episode of bluetongue was recorded in Haryana in 1972, with a morbidity of 2%. Subsequently, outbreaks were noticed regularly with

severe clinical disease during 1975 and 1982. The morbidity rate was 10% in adults and 20% in weaners with mortality rates of 0.5% and 1.3% in adults and weaners respectively (Vasudevan 1982). Bluetongue again appeared in 1985 affecting 48 Rambouillet sheep, resulting in 15 deaths among 565 animals. In 1986 and 1988 the disease occurred with 7.7% morbidity and a case fatality rate of 38.9% (Mahajan et al. 1991). Bluetongue was also noted in Russian Merinos in Himachal Pradesh in 1973: of 96 sheep, 41 were affected and eight died (Uppal and Vasudevan 1980).

The most recent data show India's bluetongue situation in 1992/93 (Table 2). Andhra Pradesh experienced severe outbreaks in September, October and November 1993. The available data suggest that bluetongue is endemic in southern India, in contrast to the absence of reports from northern India.

**Table 1.** Bluetongue outbreaks in sheep in Andhra Pradesh, 1983–1994.

Year	Organised farms			Outbreaks	Village flocks		
	Morbidity (%)	Mortality (%)	Case fatality (%)		Attacks	Deaths	Case fatality (%)
1983	7.2	1.2	16.4	1103	246737	54042	21.9
1984	2.0	–	–	–	–	–	–
1985	6.7	1.8	27.6	311	13 093	1652	12.6
1986	2.8	0.1	4.8	35	2225	99	4.4
1987	4.8	–	–	101	6609	157	2.4
1988	11.1	1.6	14.5	225	53 293	6036	11.3
1989	5.3	–	–	112	7959	523	6.6
1990	27.8	0.5	1.9	119	3719	405	10.9
1991	2.4	–	–	284	19975	1056	5.3
1992	8.1	0.6	7.3	55	929	111	11.9
1993	3.1	–	–	168	6543	306	4.7
1994	na	na	na	283	41 717	9261	22.2

na =data not available.

**Table 2.** Bluetongue situation in India in 1992 and 1993 (from Agricultural Informatics Division, Department of Animal Husbandry and Dairying, Indian Ministry of Agriculture).

State	1992			1993		
	No. of outbreaks	No. of cases	No of. deaths	No. of outbreaks	No. of. cases	No. of deaths
Andhra Pradesh	55	929	111	168	6543	306
Karnataka	7	126	15	2	2093	5
Maharashtra	4	279	49	9	271	24
Tamil Nadu	16	690	190	2	140	15
Total	82	2024	365	181	9047	350

## Species and Breeds

Antibodies to bluetongue virus (BLU) have been detected in sheep, goats, cattle and buffalo sera but not in horse and camel sera (Prasad et al. 1987). No information is available on infections in wild animals in India. However, elephants appear to show seroconversion (Mehrotra and Shukla 1990). Although Sapre (1964) reported clinical disease in sheep and goats, only sheep have been observed to exhibit characteristic clinical symptoms in all subsequent outbreaks of the disease. Cattle, goats and buffalo have not shown any clinical signs, even when they have been in close association with affected sheep and seroconversion has been recorded.

Severe clinical disease was noticed in Dorset sheep on a farm in Andhra Pradesh in 1974. However, native sheep maintained in close proximity on the same farm did not show any symptoms. The available farm data indicated that the disease did occur in native sheep from 1985 onwards. Though clinical signs of bluetongue were observed in exotic breeds (eg. Merino, Rambouillet, Corriedale, Suffolk and Dorset), another exotic breed, Karakul, maintained on the same farm did not show any symptoms (Sharma et al. 1985). Rambouillet and Merinos and their crosses were found to be more susceptible than Dorset and Suffolk breeds and their crosses. Native sheep maintained together with exotics and their crossbreds were also reported to suffer from bluetongue (Harbola et al. 1982; Sharma et al. 1985; Mullick 1988).

## Age

Our investigation in Andhra Pradesh revealed that sheep aged 6 to 12 months of age were more susceptible than adults. Disease has not been noticed in lambs. Similar observations have also been reported from Maharashtra and Haryana (Uppal and Vasudevan 1980; Harbola et al. 1982). In contrast, severe infections in adult sheep have been reported from Tamil Nadu.

## Vectors

The primary vectors of BLU viruses are midges of the genus *Culicoides*. Various species of *Culicoides* fed on viraemic sheep differed in their susceptibility to infection. The *Culicoides* species that transmit the disease vary from country to country. Jain et al. (1988) isolated BLU from *Culicoides* midges but the species involved was not identified. Information on the vector species that transmit infection in India is lacking.

## Seasonality

Maximum numbers of outbreaks in Andhra Pradesh were recorded during the south-west monsoon period (June to September), whereas in Tamil Nadu outbreaks were more frequent during north-west monsoon periods (October to December). In south India, the monsoon season (June to December), with its temperatures ranging from 21.2 to 35.6°C, appears to be a favourable period for the multiplication of *Culicoides* resulting in more outbreaks. In Haryana State in north India, outbreaks were reported between April and October. In Rajasthan, outbreaks were mostly confined to September and November (Mahajan et al. 1991; Sharma et al. 1985). The available data indicate that outbreaks were not recorded in north India during winter (December to March).

## Seroprevalence

Serological studies conducted in Andhra Pradesh using agar gel immunodiffusion (AGID) revealed the presence of antibodies in 45.7% and 43.6% of sheep and goats respectively. When a competitive enzyme linked immunosorbent assay (cELISA) was used, 5.2% more positives were detected. Prasad et al. (1987) showed the presence of BLU antibodies in 82.2% of exotic sheep which had aborted and 36.6% of apparently healthy exotic sheep in Haryana. Sodhi et al. (1981) noted antibodies in 6.6% of sheep and 1.44% of goats in Punjab State, whereas Bandopadhyay and Mullick (1983) reported 3% prevalence of BLU antibodies in goats in Uttar Pradesh.

Our investigations have revealed the presence of antibodies in 23% of native cattle and 71.9% of exotic cattle in Andhra Pradesh. Oberoi et al. (1988) demonstrated the presence of BLU antibodies in 37.5% of buffalo and 70% of cattle sera in Punjab. In Gujarat, 13.4% of buffalo and 15.6% of cattle sera were positive for BLU antibodies (Tongaonkar et al. 1983). Jain et al. (1992) noticed that the incidence of BLU antibodies was higher in buffalo (10.6%) than in cattle (4.2%). Mehrotra and Shukla (1990) reported that prevalence of BLU antibodies ranged between 16.2% and 62.2% in different states. Information is lacking on the seroprevalence of antibodies in eastern and north-eastern India.

## Bluetongue Virus Serotypes

BLU serotypes 2 and 12 were identified on the basis of neutralising antibodies in serum samples collected from experimentally inoculated sheep and cattle which, after inoculation with clinical material, seroconverted during the disease outbreak in 1993 in Andhra Pradesh. Field sera revealed neutralising anti-

bodies to BLU4, 12, 13, 14, 17, 18 and 19, indicating the circulation of multiple serotypes. Studies on the prevalence of BLU serotypes in India (Table 3) have shown a total of eight serotypes, and have identified neutralising antibodies to 17 serotypes (Vasudevan 1982; Tongaonkar et al. 1983; Janakiraman et al. 1991; Mehrotra and Misra 1993).

**Table 3.** BLU serotypes in India.

State	Species	Basis for serotyping	
		Virus	Neutralising antibodies
Tamil Nadu	sheep	3, 16	1, 4-7, 11, 12, 14-17, 19, 20
Andhra Pradesh	sheep	2	4, 12, 13, 14, 17, 18, 19
	cattle	-	6, 12
Karnataka	cattle	-	1, 14, 16
Maharashtra	sheep	1, 2, 3, 4, 9, 16, 18	-
Gujarat	buffalo	-	1, 15, 17
	cattle	-	2, 12, 20
Madhya Pradesh	sheep	18	-
Uttar Pradesh	sheep	9, 18	-
Haryana	sheep	1, 4	14
	cattle	-	1, 2, 8, 12, 16
Himachal Pradesh	sheep	3, 9, 16, 17	4
Jammu & Kashmir	sheep	18	-

## References

- Bandopadhyay, S.K. and Mullick, B.B. 1983. Serological prevalence of bluetongue antibodies in India. *Indian Journal of Animal Sciences*, 53, 1355-1356.
- Harbola, P.C., Chaudhary, P.G., Lal Krishna, Siriguppi, B.S. and Kole, R.S. 1982. Incidence of bluetongue in sheep in Maharashtra. *Indian Journal of Comparative Microbiology, Immunology and Infectious Diseases*, 3, 121-127.
- Jain, N.C., Gupta, Y. and Prasad, G. 1992. Bluetongue virus antibodies in buffaloes and cattle in Haryana State of India. In: Walton, T.E. and Osburn, B.I. ed., *Bluetongue, African horse sickness and related orbiviruses. Proceedings 2nd International Symposium*. CRC Press, Boca Raton, 188-192.
- Jain, N.C., Prasad, G., Gupta, Y. and Mahajan, N.K. 1988. Isolation of bluetongue virus from *Culicoides* species in India. *Revue Scientifique et Technique Office International des Epizooties*, 7, 375-378.
- Jain, N.C., Sharma, R. and Prasad, G. 1986. Isolation of bluetongue virus from sheep in India. *Veterinary Record*, 119, 17-18.
- Janakiraman, D., Venugopalan, A.T., Ramaswamy, V. and Venkatesan, R.A. 1991. Serodiagnostic evidence of prevalence of bluetongue virus serotypes among sheep and goats in Tamil Nadu. *Indian Journal of Animal Sciences*, 61, 497-498.
- Kulkarni, D.D., Bannaliker, A.S., Karpe, A.G., Gujar, M.B. and Kulkarni, M.N. 1992. Epidemiological observations on bluetongue in sheep in Marathwada region of Maharashtra State in India. In: Walton, T.E. and Osburn, B.I. ed., *Bluetongue, African horse sickness and related orbiviruses. Proceedings 2nd International Symposium*. CRC Press, Boca Raton, 85.
- Mahajan, N.K., Prasad, G., Jain, N.C., Dhanoa, J.S. and Gupta, Y. 1991. Epizootiological studies on bluetongue at an organised sheep breeding farm near Hissar, Haryana. *Indian Journal of Animal Sciences* 61, 1-5.
- Mehrotra, M.L. and Misra, S. 1993. Clinical symptoms and cellular reactions of bluetongue virus serotypes of Indian sheep. In: *Indian Veterinary Research Institute, Proceedings of the international symposium on virus-cell interaction: cellular and molecular responses*. Indian Veterinary Research Institute, Bangalore, 103 p.
- Mehrotra, M.L. and Shukla, D.C. 1990. Seroprevalence, diagnosis and differential diagnosis of bluetongue virus disease in India. *Indian Journal of Virology*, 1, 98-104.
- Mullick, S.G. 1988. Some epidemiological observations on the occurrence of bluetongue in organised farms in Andhra Pradesh. *Indian Journal of Comparative Microbiology, Immunology and Infectious Diseases*, 9, 201-207.
- Oberoi, M.S., Singh, G. and Kwatra, M.S. 1988. Serological evidence of bluetongue virus activity in cattle and buffalo population. *Indian Journal of Virology*, 4, 50-51.
- Prasad, G., Jain, N.C., Mahajan, N.K. and Vasudevan, B. 1987. Prevalence of bluetongue precipitating antibodies in different domestic animals. *Indian Journal of Animal Sciences*, 57, 522-524.
- Sapre, S.N. 1964. An outbreak of bluetongue in goats and sheep. *Veterinary Review*, 15, 78-80.
- Saravanabava, K. 1992. Studies on bluetongue virus in sheep. Ph.D. Thesis, Tamil Nadu Veterinary and Animal Sciences University, Madras, India.
- Sharma, M.M., Lonkar, P.S., Srivastava, C.P., Dubey, S.C., Maru, A. and Kalra, D.B. 1985. Epidemiology of bluetongue in sheep at an organised farm in semiarid part of Rajasthan, India. *Indian Journal of Comparative Microbiology, Immunology and Infectious Diseases*, 6, 188-192.
- Sodhi, S.S., Oberoi, M.S., Sharma, S.N. and Baxi, K.K. 1981. Prevalence of bluetongue precipitating antibodies in sheep and goats in Punjab, India. *Zentralblatt für Veterinärmedizin*, B., 28, 421-423.
- Srinivas, R.P., Moogi, V.M., Ananth, M., Gopal, T. and Keshavamurthy, B.S. 1982. Bluetongue disease outbreaks among sheep and goats of Karnataka. In: *Central Sheep Wool Research Institute, Abstracts of national seminar on sheep and goat disease*. Central Sheep Wool Research Institute, Avikanagar, Rajasthan, 14-20.

Tongaonkar, S.S., Ayangar, S.K., Singh, B.K. and Kant, R. 1983. Seroprevalence of bluetongue virus in Indian buffalo (*Bubalus bubalis*). *Veterinary Record*, 112, 32.

Uppal, P.K. and Vasudevan, B. 1980. Occurrence of bluetongue in India. *Indian Journal of Comparative Microbiology, Immunology and Infectious Diseases*, 1, 18-20.

Vasudevan, B. 1982. A note on bluetongue incidence among sheep in India. In: *Indian Veterinary Research Institute, Proceedings of the National Workshop on Bluetongue*. Indian Veterinary Research Institute, Izatnagar, 129-144.



# Serological Study for Bluetongue in Thailand

Bunchong Apiwatnakorn\*<sup>1</sup>, Prim Bura\*<sup>2</sup> and Orapan Pasavorakul\*<sup>3</sup>

## Abstract

Serological testing for bluetongue in Thailand began in 1991. Agar gel immunodiffusion (AGID) was used to test sera from 522 imported and domestic cattle, native sheep and goats, for which positive rates were 28.6%, 39.4% and 73.0% respectively. Though a high seropositive rate was found in native sheep, the tested animals showed no clinical disease. Bluetongue has not yet posed any significant or detectable animal health problem for ruminant farming in Thailand.

THAILAND is located on the mainland of Southeast Asia: its borders adjoin Myanmar to the west and north, Laos to the north and east, Cambodia to the east, and Malaysia to the south. Thailand's area of 513,115 km<sup>2</sup> can be divided into the fertile central plain, the mountainous north, the semi-arid northeast and the topographically diverse south. There are two distinct climates: a tropical savanna climate from the Gulf of Thailand to the north and a tropical monsoon climate in the south. The year generally has three seasons: hot, rainy, and cool, except in the south where there is no distinct cool season.

The livestock industry in Thailand is expanding both to meet the demands of the increasing domestic population and to supply world markets. Beef and dairy cattle populations are increasing, and provide an important source of cash income for villagers. Recently large numbers of breeding animals (beef and dairy cattle breeds, i.e. Brahman and Friesian) have been imported into Thailand, mainly from USA, Australia and New Zealand, and draught animals have also been imported from neighbouring countries (Table 1). In 1994, Thailand's livestock population was estimated at about 5.6 million cattle, 4.6 million buffaloes, 162 000 sheep and 120 000 goats (Table 2).

Thailand has not experienced any clinical bluetongue disease in sheep or cattle. Thailand has regulations for the importation of animal and genetic materials: the imported animals must be tested for the disease within the month before export if they are from bluetongue-infected areas, or be certified as having originated from bluetongue-free areas. However, evidence of bluetongue in Thailand has been determined by the serological testing that began in 1991.

## Methods

Serum samples were collected from 297 imported cattle, 128 native cattle, 60 sheep and 37 goats. The imported cattle were bled two to five days after arrival. All serum samples were tested for antibody to bluetongue (BLU) by agar gel immunodiffusion (AGID). The antigen was prepared from BLU1 at National Institute of Animal Health, Bangkok (Apiwatnakorn et al. 1994).

## Results

AGID tests for BLU antibody were carried out on sera collected between 1991 and 1994 from 522 imported cattle, native cattle, sheep and goats: seropositive rates were 28.6%, 59.4%, 75% and 73% respectively (Table 3).

\* Department of Livestock Development, Bangkok, Thailand (<sup>1</sup>National Institute of Animal Health; <sup>2</sup>Veterinary Service Division; <sup>3</sup>Disease Control Division).

**Table 1.** Number of imported animals/semen by export country, 1994

Export country	No. of cattle			No. of buffalo	No. of horses	Dose of cattle semen
	Beef	Dairy	Draught			
Australia	-	998	-	-	135	11 750
Canada	-	4	-	-	-	31 600
Denmark	-	-	-	-	9	-
France	-	-	-	-	-	20 000
Germany	2	-	-	-	-	20 055
Japan	-	-	-	-	-	10 000
Laos	-	-	95	2970	-	-
Malaysia	-	9	-	-	34	-
Myanmar	-	-	1353	500	-	-
Netherlands	-	-	-	-	2	-
New Zealand	4667	-	-	-	-	5815
USA	530	-	-	-	84	34 468
Total	5199	1011	1448	3470	264	133 688

(Source: Division of Planning, Department of Livestock Development, Bangkok).

**Table 2.** Livestock population in Thailand.

Year	Cattle	Buffalo	Sheep	Goats	Horses
1990	5 668 530	4 694 290	162 496	120 519	19 758
1991	6 626 971	4 805 071	166 102	136 035	20 331
1992	7 121 479	4 728 271	176 229	159 642	18 852
1993	7 472 573	4 804 146	110 465	151 860	18 047
1994	7 637 350	4 224 791	90 508	141 076	14 032

**Table 3.** Results of serological testing by AGID for bluetongue virus antibodies, Thailand 1991 to 1994.

Animals	Total no. of animals tested	No. positive (%)
Imported cattle	297	85 (28.7%)
Native cattle	128	76 (59.4%)
Sheep	60	45 (75.0%)
Goats	37	27 (73.0%)

## Discussion

Although BLU antibodies were detected in Thailand in sera from native cattle, sheep and goats, clinical signs have not been seen nor has virus been isolated. In many countries, the prevalence of infection in ruminants has been reported as greater than 50% even though clinical disease has never been recorded (Gibbs and Greiner 1988). This study suggests that BLU may occur in Thailand, which is a tropical country suitable for BLU vectors. Blue-

tongue infections are common in sheep, cattle and other ruminants in most tropical, subtropical and temperate zones of the world (Eaton et al. 1989). The distribution of BLU is focal, with the focality depending primarily on the range of the host reservoir, vector and domestic animals. As the range of vectors depends on temperature and water availability, BLU will spread more rapidly at warm temperatures as vectors develop to maturity more rapidly (Shope 1992).

Despite Thailand's regulations for importing animals and genetic materials (including BLU testing within one month of shipment), some imported cattle have shown positive reactions to BLU. Although this study focuses only on serological studies, our results are expected to warn all those concerned with importing animals and/or genetic materials into Thailand to prevent the introduction of exotic viruses.

## Acknowledgments

The National Institute of Animal Health, Japan, provided BLU1 seed for antigen preparation, and the Department of Livestock Development provided resources and facilities.

## References

- Apiwatnakom, B., Supcharoen, A., Ekgatit, M. and Gagornsombat, D. 1994. Bluetongue antigen preparation for agar gel immunodiffusion test. *Kasetsart Animal Hospital Journal*, 5 (1-2), 1-5.

Eaton, B.T., Hyatt, A.D., Gould, A.R. and White, J.R. 1989. The structure of bluetongue virus. Biennial Report 1987-1989 CSIRO Australian Animal Health Laboratory, 65-70.

Gibbs, E.P.J. and Greiner, E.C. 1988. Bluetongue and epizootic hemorrhagic disease. In: Monath, T.P., ed., The arboviruses: epidemiology and ecology, vol. II. CRC Press, Boca Raton, 39-70.

Shope, R.E. 1992. Health implications of arboviral diseases resulting from global changes. In: Walton, T.E. and Osburn, B.I. ed., Bluetongue, African horse sickness and related orbiviruses. Proceedings 2nd International Symposium. CRC Press, Boca Raton, 9-13.

# Recent Studies on Bluetongue in Peninsular Malaysia

S.S. Hassan\*, G.P. Gard†, I. Polkinghorne§, M.A. Abdul Rahman\*,  
A. Aziz Hussin\*, M. Maizan\*, M. Zainal\* and L. Aminah Kadariah\*

## Abstract

Bluetongue is endemic in Malaysia. Bluetongue virus infection is widespread among local cattle, buffalo, sheep and goats, but the clinical form of the disease is inapparent in indigenous sheep. The Veterinary Research Institute and CSIRO collaborated to investigate bluetongue in Malaysia. Sentinel groups of cattle and sheep were established at four sites throughout the country. Blood samples from these sentinels were collected over a nine-month observation period. Sixteen viruses isolated from heparinised blood samples were typed by the plaque-reduction test into six different serotypes: BLU1, 2, 3, 9, 16 and 23. The pathogenicity of five bluetongue virus serotypes was studied by intravenous inoculation of 0.5 mL heparinised blood of the original isolates into progenies of imported commercial Merino-Border Leicester crossbred sheep, shown free of bluetongue antibodies by AGID and competitive ELISA. Although virus titres in their blood ranged from  $10^{2.4}$  to  $10^{1.9}$  ECE LD<sub>50</sub>/0.5 mL, the sheep did not show any clinical signs.

THE first documented evidence of bluetongue in Malaysia came in 1977 when antibodies were detected by agar gel immunodiffusion (AGID) tests in healthy local and imported ruminants (Anon. 1978). However, despite the serological evidence of bluetongue infection, local animals seemed naturally resistant as no overt clinical signs were reported.

In October 1987, an outbreak of bluetongue occurred in Malaysia in a batch of sheep imported from South Australia (Chiang 1989). Bluetongue virus (BLU) serotype 1 was recovered from one of the dead sheep and serological evidence also indicated presence of BLU3 and BLU8 (serotyping by Pirbright Laboratories, U.K.). During the outbreak, the local in-contact goats and sheep did not suffer from the disease. In 1990, following the outbreak, another comprehensive serological survey involving

16 340 ruminant animals was conducted using AGID (Della-Porta et al. 1983). In that survey, virus replication appeared to be highly active among cattle and buffalo in comparison to recently imported Poll Dorset sheep and local goats. These results add to the evidence that BLU infection is widespread and endemic in Malaysia.

The incidence of bluetongue disease has caused great concern to the sheep industry, as Malaysia's aim to increase the genetic potential of its breeding stock now faces a major problem in the susceptibility of imported animals to bluetongue. A collaborative research program to investigate bluetongue in West Malaysia was therefore developed between Malaysia and the Bureau of Rural Research, Australia. The main aim was to accumulate more data on the disease status in Malaysia in order to formulate suitable and effective control measures for BLU infections in sheep. As there are 24 BLU serotypes known worldwide, the preliminary project was targeted at the isolation, identification and characterisation of BLU serotypes causing clinical disease in Malaysia. This paper outlines current research findings on the epidemiology of BLU infections in Malaysia and discusses prospects for the control of the disease, especially in imported temperate breeds.

\* Veterinary Research Institute, PO Box 369, 30740 Ipoh, Perak, Malaysia.

† Bureau of Resources Science, Department of Primary Industries and Energy, PO Box E11, Queen Victoria Terrace, Parkes, ACT 2601 Australia.

§ Queensland Department of Primary Industries, PO Box 1085, Townsville, Queensland 4810, Australia.

## Current Research Findings on the Epidemiology of Bluetongue

### Occurrence of *Culicoides* species

Bluetongue viruses, like many other orbiviruses, are dependent on *Culicoides* for their natural transmission. *Culicoides brevitarsis*, the main BLU vector in Australia, also occurs in Papua-New Guinea, Solomon Islands and Indonesia (Doyle 1992). However, in a survey of *Culicoides* species collected in five sheep sheds in West (peninsular) Malaysia, *C. brevitarsis* was collected from only two farms and in very low numbers. On the basis of observed abundance, distribution and host preference, *C. peregrinus*, *C. orientalis* and *C. shortii* are considered the important BLU vectors in Malaysia (Cheah and Rajamanickum 1991).

Vector competence studies need to be conducted on these three species, and on several others collected near livestock. Studies of the genetic and environmental factors controlling the complex traits of vector capacity, vector-virus-host interactions and vector ecology will be of considerable importance in achieving a full understanding of bluetongue disease, epidemiology and use of vaccines. However, there is a current lack of expertise and facilities in these various disciplines in Malaysia to support such research.

### Sentinel herds

In the absence of clinical bluetongue disease in local ruminants, the use of sentinel herds was the most effective approach to obtaining BLU isolates. In March 1991, three herds of sentinel calves, tested negative for BLU antibodies by AGID, and an antibody-negative flock of adult sheep were established on four government farms in West Malaysia. Heparinised and clotted blood samples were collected weekly or biweekly from each individually-

identified sentinel animal over a nine-month observation period. During this study, BLU infections of sentinels were found to be associated with periods of higher rainfall, with the incidences of seroconversions being markedly higher in cattle than in sheep (Sharifah et al. 1995).

### Virus isolation and serotyping

The sera of the sentinel animals were examined by AGID for antibodies to bluetongue and the heparinised bloods of seroconverting animals were tested for the presence of virus (Gard et al. 1988). Briefly, virus recovery was attempted in an isolation system involving passage through embryonated chicken eggs (ECE), the C6/36 cell line of *Aedes albopictus*, and BHK21 cell cultures. Virus was detected by the microscopic observation of cytopathic effect (CPE) in the BHK21 cell monolayers. Cytopathic agents were grouped as BLU by an indirect immunospot peroxidase test using a monoclonal antibody to VP7 of BLU1 (Gard and Kirkland 1993). Viruses serogrouped as BLU were then serotyped in a plaque reduction test (Gard and Kirkland 1993) against reference antisera (supplied by Dr B. Erasmus, Veterinary Research Institute, Onderstepoort, Republic of South Africa) to each of the 24 internationally recognised BLU serotypes. Sixteen bluetongue viruses were recovered from the heparinised bloods of seroconverting sentinels: one was from a sheep in Pusat Pembiakan Kambing, Kuala Pah, and the remainder were from cattle from all three sites (Table 1). From the 16 isolates, 6 serotypes BLU1, 2, 3, 9, 16 and 23 (Table 1; Sharifah et al. 1995) were identified, with serotype identities confirmed by Dr B. Erasmus.

At the Veterinary Research Institute, Perak, work is continuing on isolating BLU, especially from sick and aborting sheep as isolations from these sheep

**Table 1.** Bluetongue virus serotypes isolated from heparinised blood collected from sentinel livestock at four sites in Peninsular Malaysia.

Location	Month of blood collection				
	May 1991	June 1991	October 1991	December 1991	January 1992
Batu Arang		BLU2		BLU1	BLU1
		BLU2		BLU3	BLU1
					BLU3
Jelai Gemas	BLU1	BLU1			BLU23
	BLU9	BLU2			
		BLU16			
Kuala Pah	BLU1				
Sungai Siput	BLU1		BLU16		

may reflect the virulence of the virus. To date, three bluetongue viruses have been isolated from sick sheep in Institute Haiwan, Kluang, although these viruses have not yet been serotyped.

#### Pathogenicity of Malaysian BLU viruses in crossbred sheep

Sharifah et al. (1996) studied the pathogenicity of five serotypes of BLU isolates. The trial was conducted on the progeny of commercial Merino–Border Leicester crossbreds in a *Culicoides*-proof room, using twelve sheep tested as free of BLU antibodies by AGID and cELISA (Gard and Kirkland 1993). Heparinised blood (0.5 mL) containing viruses of each of the original isolates from the sentinels (BLU1, 2, 3, 9 and 23) was administered intravenously to two sheep (i.e. each virus serotype was inoculated into two sheep). Two sheep were not inoculated and kept as controls. The viruses were titrated by the intravenous inoculation of infected blood into 11- to 13-day-old ECE. As calculated by the method of Reed and Muench (1938), the titres of the viruses were low ( $10^{2.4}$  ECE  $LD_{50}/0.5$  mL to  $10^{1.9}$  ECE  $LD_{50}/0.5$  mL). The progeny of the imported crossbred sheep did not show any clinical signs of bluetongue (Table 2) except for a mild rise in body

temperature (1–2°C) in two sheep (one inoculated with BLU9, the other with BLU23 at 5 days post-infection). However, as one sheep in the control group also showed a rise in body temperature this response may not be indicative of BLU infection. In this trial, all the viruses were reisolated from the sheep's heparinised blood, collected on days 5 and 8 (i.e. at peak virus titres; Uren and Squire 1982), indicating the presence of virus in peripheral blood. The lack of clinical signs suggested some degree of tolerance or resistance to the disease in the sheep. However, because they did not produce disease in crossbreds, the virulence of these viruses cannot be determined until susceptible purebred sheep are used in pathogenicity trials.

#### Isolation of BLU viruses from pneumonic lungs

BLU isolations were attempted on 200 pneumonic lung samples submitted to the laboratory by three government farms with problems of pneumonia in sheep. Virus isolations were conducted in ECE as previously described. Although BLU antigen-capture ELISA (Meecham 1992) was conducted to detect any bluetongue viruses from the harvested and homogenised liver and heart of the egg embryos, none were isolated from any of the samples.

**Table 2.** Responses of sheep to five Malaysian bluetongue virus serotypes.

Virus serotypes	Titres ECE $LD_{50}/0.5$ mL	Sheep no.	Rectal temperature (dpi <sup>a</sup> )	AGID		Competitive ELISA <sup>b</sup>	Antigen capture <sup>c</sup> ELISA on egg embryos
				21 dpi	35 dpi	21 dpi	
1	$10^{2.2}$	L101T	–	–	–	low +ve	positive
		L1100	–	–	–	low +ve	positive
2	$10^{2.0}$	L989	–	–	–	low +ve	positive
		L1030	–	–	–	low +ve	positive
3	$10^{2.0}$	L1480	–	–	–	low +ve	positive
		L702	–	–	–	low +ve	positive
9	$10^{1.9}$	L1497	5th dpi	–	1+	+ve	positive
		L1500	–	2+	2+	+ve	positive
23	$10^{2.4}$	L984	–	–	2+	+ve	positive
		L985	5th dpi	–	–	low +ve	positive
Control		1486	–	–	–	–	negative
		1478	5th dpi	–	–	–	negative

<sup>a</sup> dpi = days post-infection

<sup>b</sup> % inhibition >50%+

% inhibition < 40%–

negative controls O.D. 1.1–1.6.

<sup>c</sup> OD > 0.25+

## Proposed Measures for Control

### Import regulations

As both bluetongue viruses and disease have been identified in Malaysia, overemphasis on importation of seronegative, susceptible animals will result in losses from infections contracted after arrival in this country. Provision of vaccines should be part of all national livestock development programs which involve the introduction of exotic breeds. One of the problems with BLU vaccination is that immunity afforded by one serotype does not protect against others. Identification of pathogenic BLU serotypes present in the country is extremely valuable in enabling the efficient immunisation of susceptible sheep before importation, thus avoiding the uncontrolled introduction of BLU vaccine viruses which may be inappropriate for protection against local serotypes.

However, due to genetic differences even within similar serotypes, there is concern that vaccine virus may reassort with Malaysian viruses resulting in more virulent strains. One way to minimise this risk is to hold sheep for at least 14 days after vaccination in the exporting country to allow virus clearance before importing them into Malaysia. This is useful because viraemia in sheep increases rapidly to a peak on the 5th to 8th day after infection, decreasing rapidly to be scarcely detectable on the 11th to 12th day (Luedke 1969; Uren and Squire 1982; Jeggo et al. 1985). Further surveillance of these sheep after importation should include regular clinical and serological monitoring.

### Embryo transfer

For a country with endemic bluetongue, reproductive technology such as embryo transfer has been suggested as a cheaper and safer means of animal introduction (Doyle and Howard 1992). The passive immunity transferred to exotic offspring from local recipient dams could result in their protection, a control mechanism unavailable in introduced adult animals. Embryo transfer using local recipients avoids the risk of pregnancy wastage that may occur if pregnant animals are imported. However, the use of embryo transfer technology for this purpose in Malaysia would require the capability and the resources to perform it successfully.

### Development of Vaccines from Local Isolates

With the availability of Malaysia's own BLU isolates, the possibility of the local production of vaccines could be considered. Vaccination produces solid immunity against homologous challenge but

variable protection against heterologous infection. The development of any vaccine in Malaysia would have to be from local strains to avoid the possibility of gene reassortment among exotic strains and endemic Malaysian strains. Polyvalent vaccines would have to be produced against all pathogenic serotypes. However, limited demand is foreseen as vaccines are recommended only for susceptible imported temperate sheep. Moreover, the perception and expectation that a new generation of genetically engineered or synthetic vaccines or immunogens may soon be forthcoming could be additional disincentives to the development of local vaccines.

## Conclusion

Bluetongue virus research in Malaysia will be partly influenced by the breeds of sheep imported into the country. However, it is imperative that continued support and resources be allocated to the development of systematic national surveillance using sentinels and diagnostic programs.

## Acknowledgments

Dr Nor Aidah A.R. critically reviewed this paper. Tan C.L. and Liew S.W. prepared the visuals.

## References

- Anon. 1978. Report to the Director General of Veterinary Services on the serological survey for bluetongue in Peninsular Malaysia. Department of Veterinary Services, Malaysia, 1-15.
- Cheah, T.S. and Rajamanickam, C. 1991. Occurrence of *Culicoides* spp. in sheep sheds and their relevance to bluetongue in Peninsular Malaysia. *Tropical Animal Health and Production*, 23, 63-65.
- Chiang, B.L. 1989. An outbreak of bluetongue in imported sheep. In: *Veterinary Association Malaysia, Proceedings, First Congress*, 40-52.
- Della-Porta, A.J., Sellers, R.F., Herniman, K.A.J., Littlejohns, I.R., Cybinski, D.H., StGeorge, T.D., McPhee, D.A., Snowdon, W.A., Campbell, J., Cargill, C., Corbould, A., Chung, Y.S. and Smith, V.W. 1983. Serological studies of Australian and Papua New Guinean cattle and Australian sheep for presence of antibodies against bluetongue group viruses. *Veterinary Microbiology*, 8, 147-162.
- Doyle, K.A. 1992. An overview and perspective on orbivirus disease prevalence and occurrence of vectors in Australia and Oceania. In: Walton, T.E. and Osburn, B.I., ed., *Bluetongue, African horse sickness and related orbiviruses. Proceedings 2nd International Symposium*. CRC Press, Boca Raton, 44-57.
- Doyle, K. and Howard, T. 1992. Working Team Report on international impacts. In: Walton, T.E. and Osburn, B.I., ed., *Bluetongue, African horse sickness and related orbi-*

- viruses. Proceedings 2nd International Symposium. CRC Press, Boca Raton, 965-970.
- Gard, G.P. and Kirkland, P.D. 1993. Bluetongue; virology and serology. In: Bagust, T. and Corner, L. ed., Australian standard diagnostic techniques for animal diseases. CSIRO, Melbourne, 1-17.
- Gard, G.P., Weir, R.P. and Walsh, S.J. 1988. Arboviruses recovered from sentinel cattle using several virus isolation methods. *Veterinary Microbiology*, 18, 119-125.
- Jeggo, J.M., Corsteyn, A.H., Taylor, W.P., Davidson, W.L. and Gorman, B.M. 1985. Virulence of bluetongue virus for British sheep. *Research in Veterinary Science*, 42, 24-28.
- Luedke, A.J. 1969. Bluetongue in sheep: viral assay and viraemia. *American Journal of Veterinary Research*, 30, 499-509.
- Meecham, J.O. 1992. Detection of bluetongue viruses by an antigen-capture enzyme-linked immunosorbent assay. In: Walton, T.E. and Osburn, B.L., ed., Bluetongue, African horse sickness and related orbiviruses. Proceedings 2nd International Symposium. CRC Press, Boca Raton, 666-670.
- Reed, L.J. and Muench, H. 1938. A simple method for estimating fifty percent end-points. *American Journal of Hygiene*, 27, 493-497.
- Sharifah, S.H., Ali, A.R., Aziz, H., Maizan, M., Aminahkariah, A.L. and Zainal, M. 1996. Failure of 5 Malaysian bluetongue virus serotypes to induce clinical disease in crossbred sheep. *Journal of Veterinar Malaysia*.
- Sharifah, S.H., Ali, A.R., Gard, G.P. and Polkinghorne, I.G. 1995. Isolation of multiple serotypes of bluetongue virus from sentinel livestock in Malaysia. *Tropical Animal Health and Production*, 27, 37-42.
- Uren, M.F. and Squire, K.R.E. 1982. The clinico-pathological effect of bluetongue virus serotype 20 in sheep. *Australian Veterinary Journal*, 58, 1, 11-15.



# Bluetongue Virus Research in Indonesia

I. Sendow\*, Sukarsih\*, E. Soleha\*, M. Pearce†, S. Bahri\* and P.W. Daniels§

## Abstract

Sentinel herds were established in West Java, Bali, Nusa Tenggara Timur and Irian Jaya to determine the presence and seasonality of bluetongue virus (BLU) infection in Indonesia. Insects were collected near sentinel sites. BLU isolates were obtained from cattle blood and insects. Serological results indicated that seroconversion mostly occurred at the end of the wet season and that large ruminants had a higher prevalence of antibody than small ruminants. BLU serotypes 1, 3, 7, 9, 12, 16, 21 and 23 were successfully isolated from blood from apparently healthy cattle: BLU21 was also isolated from a pool of *Culicoides fulvus* and *C. orientalis*. The pathogenicity of BLU isolates was determined in local and imported sheep.

BLUETONGUE disease does not affect Indonesian livestock. However, an outbreak of clinical disease suspected as bluetongue was reported where imported Suffolk sheep from Australia were raised in West Java (Sudana and Malole 1982). It has since been recognised that in many tropical countries bluetongue viruses (BLU) may be circulating inapparently, without causing disease in local sheep (Gibbs et al. 1989; Sendow et al. 1992). The outbreak in West Java appears analogous to that reported in Cameroon in which imported sheep succumbed to bluetongue disease while local sheep were unaffected (Ekue et al. 1985).

A serological survey indicated that several BLU serotypes were widespread on the main islands of Indonesia (Sendow et al. 1986, 1991a). A program to study bluetongue viruses in Indonesia in greater detail was therefore implemented. Since bluetongue disease did not appear to be causing financial loss to

farmers, the bluetongue work was incorporated into a broader plan to study several arboviruses of veterinary significance (Daniels et al. 1991, 1995).

## Components of the Indonesian Bluetongue Research Program

The first objective was to obtain local BLU isolates, for without these the presence of bluetongue would remain unconfirmed. The Australian model of monitoring well-placed sentinel herds of cattle (St. George 1980) was adopted. The development of the sentinel program in Indonesia has already been described by Sendow et al. (1988, 1989, 1992). The initial serological survey confirmed the experiences of other countries, i.e. that large ruminants had higher prevalences of exposure than small ruminants (Sendow et al. 1986). Cattle were therefore used in sentinel groups monitored for virus isolation: these animals were introduced to the program at a young age to allow sampling of naive animals during the course of primary viral infections. Cattle were sampled weekly; blood was processed for virus isolation and held for serology and further virological studies.

Sentinel groups were placed in areas with significant livestock populations, at locations considered suitable for vector, and hence virus, activity. Major sampling sites were Depok, West Java; Denpasar,

\* Research Institute for Veterinary Science, PO Box 52, Bogor 16114, Indonesia.

† Indonesia International Animal Science Research and Development Foundation (INI ANSREDEF), PO Box 1093, Bogor 16010, Indonesia.

§ CSIRO Australian Animal Health Laboratory, PO Bag 24, Geelong, Victoria 3220, Australia.

Bali; Kupang in Nusa Tenggara Timur (NTT) province; and Jayapura and Merauke in Irian Jaya (Fig. 1; Sendow et al. 1992). From time to time, sentinels were established at other sites to fulfil specific objectives, for example at Cisarua in West Java to allow comparison between this high altitude site and the low altitude site at Depok.

To identify potential vectors and their seasonal abundance, insects were collected at sentinel sites using light traps (Sukarsih et al. 1993). As Depok and Cisarua were near the laboratory, attempts were made to isolate viruses from freshly caught insects.

Isolation and characterisation of isolates to serotype allowed comparisons to be made with the situations in neighbouring countries, with the aim of developing a regional perspective of these BLU infections (Daniels et al. 1995; Daniels and Melville 1996). This approach is now being extended through molecular studies of the isolates (Daniels et al. 1995; Sendow et al. these Proceedings). Isolation of local BLU strains has allowed the start of pathogenicity tests to study aspects such as the virulence of local strains and the apparent resistance of local sheep.

### Viruses Isolated from Sentinel Cattle

Initially, virus isolation was attempted by inoculation of samples into baby hamster kidney cell cultures (BHK21). However, a protocol based on intravenous inoculation of embryonated chicken eggs (ECE) followed by blind passage in *Aedes albopictus* cell cultures (C6/36) before passage to BHK21 was soon adopted (Sendow et al. 1993a, 1993b). Subsequent identification of viruses to groups used tests based on

the BLU group-specific monoclonal antibody 20E9b762 (Lunt et al. 1988; Sendow et al. 1993a), with serotyping being requested at international reference laboratories.

Isolation of BLU viruses has been confirmed only from the Depok and Jayapura sentinel sites, although further isolates remain to be characterised (Table 1). The first serotypes reported were BLU7 and BLU9 (Sendow et al. 1991b), with BLU1, 12, 21 and 23 subsequently identified at Depok (Sendow et al. 1993a) and BLU1, 21 and 23 from Jayapura (Sendow et al. 1993b); two further serotypes have since been identified, BLU3 from Depok and BLU16 from Jayapura (Table 2).

**Table 1.** Results of viral isolation from heparinised sentinel cattle blood in Indonesia, 1989–1993.

Area	No. of specimens processed	Isolates	BLU group isolates
Bali	221	10	10
Irian Jaya	1327	46	11
West Java	1584	49	18
West Timor	1536	24	32
Total	4668	129	61

Confirmed BLU isolations have been made from January to June (Table 2), which is the period from the middle to the end of the wet season (Sendow et al. 1992). At Jayapura isolates were obtained throughout the wetter months, from November to May (Table 2; Sendow et al. 1992). At both locations, however, ade-

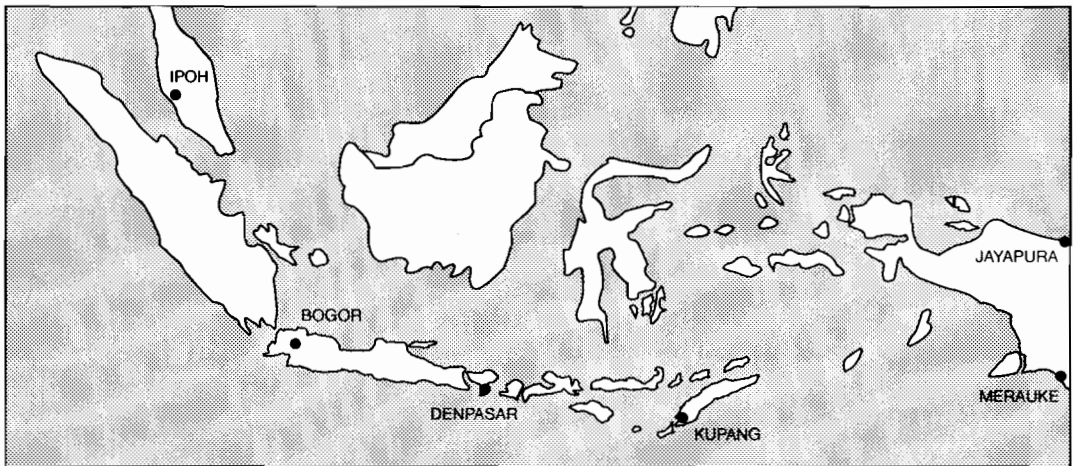

**Figure 1.** Map of Indonesia showing sentinel herd sampling sites.

quate rainfall to maintain vector populations occurs throughout the year (Sukarsih et al. 1993). The isolations to date probably identify peaks of activity rather than an absolute presence or absence of BLU infections.

**Table 2.** Bluetongue viruses isolated from sentinel cattle in Indonesia, 1988–1990.

Province and site	Animal no.	Date sampled	Bluetongue (BLU) serotype
Depok, West Java	D15	9 March 88	9
	D54	6 June 88	7
	D124	20 January 90	9
	D153	19 March 90	3
	D150	2 April 90	21
	D155	9 April 90	21
	D154	9 April 90	12
	D163	29 May 90	1
	D165	25 June 90	21
Jayapura, Irian Jaya	1166	11 November 89	23
	1169	16 December 89	16
	1159	23 January 90	23
	1164	13 February 90	21
	1163	29 May 90	1

### Vector Studies

To confirm the vector status of an insect for an arbovirus must involve experimentally proving the insect's ability to transmit the virus biologically from mammalian host to mammalian host after a period of virus replication within the insect. Since such studies have not yet been possible in Indonesia, studies of potential vectors have been based on the assumption that insects implicated as vectors in neighbouring countries may also be vectors in Indonesia. Attention has thus focused on certain species of *Culicoides* shown to be vectors in Australia (Standfast et al. 1985). *Culicoides* populations adjacent to sentinel cattle have been sampled, and much is now known of the *Culicoides* fauna of livestock-producing areas in Indonesia (Sukarsih et al. 1993).

Insects collected at Depok were identified to species, pooled and processed for virus isolation (Sendow et al. 1993c). From more than 1000 pools processed, 16 isolates have been yielded, of which five were identified as BLU in grouping tests. Emphasis was

given to *Culicoides* of the subgenus *Avaritia*, which contains the known Australian vector species. Other *Culicoides* species shown to support virus replication (Standfast et al. 1985) were also processed, as were pools of mosquitoes to isolate other arboviruses. The confirmed BLU isolates from insects (Table 3) include an isolate from a pool of *Aedes* mosquitoes (Sendow et al. 1994).

**Table 3.** Bluetongue viruses isolated from insects at Depok, West Java.

Insect pool	Date	Bluetongue (BLU) serotype
<i>Culicoides fulvus</i> and <i>C. orientalis</i>	May 91	21
<i>Anopheles</i> spp.	May 91	21
<i>C. fulvus</i>	April 92	1
<i>C. perigrinus</i>	April 92	21

### Pathogenicity Studies

The pathogenicity studies were aimed at determining the virulence of Indonesian BLU isolates. Since naturally-occurring clinical disease had been reported in imported sheep but not in local sheep, perhaps because of resistance factors, local sheep were considered unsuitable for experiments. Instead sheep known to be susceptible were used, with aged Merino sheep from north-western Queensland being donated by the Queensland Department of Primary Industries: such animals have been reported more susceptible in pathogenicity trials in Australia (Johnson et al. 1992).

Collection protocols from sentinel animals provided for the storage of heparinised whole blood at each sampling, so as to have aliquots of viraemic blood for further studies in the event of a viral isolate being obtained at any sampling. Natural virulence of BLU strains can only be assessed using virus not passaged in eggs or cell cultures (Johnson et al. 1992). Preliminary inoculations of susceptible Merino sheep were conducted to propagate adequate stores of infected blood for the trials. Pairs of sheep were inoculated with cattle blood from which BLU1, 9, 21 and 23 had been isolated. Sheep inoculated with viraemic blood of BLU1, 9 and 21 responded clinically and seroconverted. Blood for further transmissions was collected during the febrile period.

Groups of Merino and local Indonesian sheep were then inoculated with infected sheep blood. Most sheep showed some clinical signs, had detectable viraemias and seroconverted. However, the clinical signs were mild and mainly limited to mild oedema of facial tis-

sues, mild hyperaemia of mucous membranes and, in a few cases, coronary bands. It was concluded that, under the experimental conditions, the isolates tested were of low pathogenicity.

## Discussion

The bluetongue research program in Indonesia has yielded eight BLU serotypes recognised by international reference laboratories BLU1, 3, 7, 9, 12, 16, 21, and 23. With potential for a still greater yield of isolates, the program has thus had considerable success in defining the bluetongue status of Indonesia. Serological studies in association with sentinel monitoring confirm the widespread prevalence of animals exposed to these viruses.

As further serotypes become available, further pathogenicity tests should be conducted. The inclusion of local sheep in such studies should be continued, for this has led to the first observations of clinical signs associated with bluetongue infections in local sheep. Although only mild responses were observed, it would be useful to extend the range of observations.

Perhaps more importantly, further trials should also address the apparent discrepancy between the observation of natural disease in imported sheep but not in experimental infections of such animals. Mild disease may not be a feature of infections with all Indonesian serotypes or strains. Commercial interests periodically consider establishing farming systems based on imported Australian sheep. A full understanding of factors leading to disease is important to support such international trading initiatives, which would benefit both countries.

## Acknowledgments

Dr Eha Soleha's major role in the sentinel program, including active participation in field work and serological and virological studies, is acknowledged respectfully. Technical assistance was provided by Sdr Iman Salihin, Risa Indriani, Ace Endang, M. Sulaiman, Hannipah Aryana, Maria Goretti, Ekon, Kordir, Anna, Saepudin, Edi Satria, Suminta, Cornelia Halim and Neville Hunt. Field work was assisted by the provincial offices of the Dinas Peternakan and by the Disease Investigation Centre, Denpasar. Dr G.P. Gard advised on the design of pathogenicity studies. The work was substantially assisted by the Australian Quarantine and Inspection Service under the Northern Australia Quarantine Surveillance program.

## References

- Daniels, P.W. and Melville, L. Arboviruses of livestock in the Northern Territory. CSIRO and Northern Territory DPIF. 1996
- Daniels, P. W., Sendow, I., Soleha, E., Jennings, J. and Sukarsih. 1991. A veterinary arbovirus monitoring program. In: Martin, S.W., ed., Proceedings 6th Congress of the International Society for Veterinary Epidemiology and Economics. ISVEE, Ottawa, 207-209.
- Daniels, P.W., Sendow, I., Soleha, E., Sukarsih, Hunt, N.T. and Bahri, S. 1995. Australian-Indonesian collaboration in veterinary arbovirology. A review. *Veterinary Microbiology*, 46, 151-174.
- Ekue, F.N., Nfi, A.N., Tsangue, T., Taylor, W.P. and Gumm, I.D. 1985. Bluetongue in exotic sheep in Cameroon. *Tropical Animal Health and Production*, 17, 187-188.
- Gibbs, E.P.J., Greiner, E.C., Homan, E.J., Yuill, T.M., Mo, C.L. and Walton, T.E. 1989. Bluetongue and ecosystems a New World perspective. In: Uren, M.F., Blok, J. and Manderson, L.H., ed., Arbovirus research in Australia. Proceedings 5th Symposium. CSIRO/Queensland Institute of Medical Research, Brisbane, 293-297.
- Johnson, S.J., Hoffmann, D., Flanagan, M., Polkinghorne, I.G. and Bellis, G.A. 1992. Clinico-pathology of Australian bluetongue virus serotypes for sheep. In: Walton, T.E. and Osburn, B.J., ed., Bluetongue, African horse sickness and related orbiviruses. Proceedings 2nd International Symposium. CRC Press, Boca Raton, 737-743.
- Lunt, R.A., White, J.R. and Blacksell, S.D. 1988. Evaluation of a monoclonal antibody blocking ELISA for the detection of group specific antibodies to bluetongue virus in experimental and field sera. *Journal of General Virology*, 69, 2729-2740.
- Sendow, I., Daniels, P.W., Cybinski, D.H., Young, P.L. and Ronohardjo, P. 1991a. Antibodies against certain bluetongue and epizootic haemorrhagic disease viral serotypes in Indonesian ruminants. *Veterinary Microbiology*, 28, 111-118.
- Sendow, I., Daniels, P.W., Soleha, E., Erasmus, B., Sukarsih and Ronohardjo, P. 1993a. Isolation of bluetongue virus serotypes new to Indonesia from sentinel cattle in West Java. *Veterinary Record*, 133, 166-168.
- Sendow, I., Daniels, P.W., Soleha, E., Hunt, N., Bale, A. and Ronohardjo, P. 1989. Studies on orbiviral infections of sentinel ruminants in Indonesia. In: Uren, M.F., Blok, J. and Manderson, L.H. ed., Arbovirus research in Australia. Proceedings 5th Symposium. CSIRO/Queensland Institute of Medical Research, Brisbane, 311-315.
- Sendow, I., Daniels, P.W., Soleha, E., Hunt, N. and Ronohardjo, P. 1991b. Isolation of bluetongue viral serotypes 7 and 9 from healthy sentinel cattle in West Java, Indonesia. *Australian Veterinary Journal*, 68, 405.
- Sendow, I., Daniels, P.W., Soleha, E. and Sukarsih. 1992. Epidemiological studies of bluetongue viral infections in Indonesian livestock. In: Walton, T.E. and Osburn, B.J. ed., Bluetongue, African horse sickness and related orbiviruses, Proceedings 2nd International Symposium. CRC Press, Boca Raton, 147-154.

- Sendow, I., Hunt, N., Bale, A., Bartz, C., Tarmudji, Ronohardjo, P. and Daniels, P.W. 1988. Studies of arboviral infections of sentinel cattle in Indonesia. In: Sastradipradja, D. and Sigit, S.H., ed., Proceedings 6th FAVA Congress, Denpasar, Indonesian Veterinary Association, Jakarta, 367-373.
- Sendow, I., Soleha, E., Daniels, P.W., Sebayang, D., Achdiyati, J., Karma, K. and Erasmus, B.J. 1993b. Isolation of bluetongue virus serotypes 1, 21 and 23 from healthy cattle in Irian Jaya, Indonesia. *Australian Veterinary Journal*, 70, 229-230.
- Sendow, I., Sukarsih, Soleha, E. and Daniels, P.W. 1994. Isolation of bluetongue virus serotype 21 from mosquitoes in West Java, Indonesia. *Penyakit Hewan*, 26 (48), 21-25.
- Sendow, I., Sukarsih, Soleha, E., Erasmus, B.J. and Daniels, P.W. 1993c. Isolation of bluetongue virus serotype 21 from *Culicoides* spp. in Indonesia. *Veterinary Microbiology*, 36, 349-353.
- Sendow, I., Young, P., and Ronohardjo, P. 1986. Preliminary survey for antibodies to bluetongue-group virus in Indonesian ruminants. *Veterinary Record*, 119, 603.
- Standfast, H.A., Dyce, A. L. and Muller, M.J. 1985. Vectors of bluetongue in Australia. In: Barber, T.C., Jochim, M.S. and Osburn, B.I. ed., *Bluetongue and related orbiviruses. Progress in Clinical and Biological Research*, vol. 178, Alan R. Liss Inc., New York, 177-186.
- St. George, T.D. 1980. A sentinel herd system for the study of arbovirus infections in Australia and Papua-New Guinea. *Veterinary Science Communications*, 4, 39-51.
- Sudana, I.G. and Malole, M. 1982. Penyidikan penyakit hewan bluetongue di desa Caringin, Kabupaten Bogor. In: *Annual report of disease investigation in Indonesia during the period of 1975-1981*, Direktorat Kesehatan Hewan, Direktorat Jenderal Peternakan, Jakarta, 110-121.
- Sukarsih, Daniels, P.W., Sendow, I. and Soleha, E. 1993. Longitudinal studies of *Culicoides* spp. associated with livestock in Indonesia. In: Uren, M.F. and Kay, B.H. ed., *Arbovirus research in Australia. Proceedings 6th Symposium*. CSIRO/Queensland Institute of Medical Research, Brisbane, 203-209.

# The History of Bluetongue in Australia and the Pacific Islands

T.D. St. George\*

## Abstract

Between 1959 and 1977 in Australia there was a long period of development of virology and vector expertise in preparation for bluetongue. Nevertheless, the initial discovery of bluetongue virus (BLU) in 1977 near Darwin was unexpected. Near that location, eight BLU serotypes have been discovered in Australia since 1977 although only two are continually present. Five of the serotypes are highly virulent but they have not persisted as silent infections of cattle and buffalo for more than a few years, nor have they spread far from their initial focus in the far north of the Northern Territory. Serotype 1 has spread beyond Australia and Papua New Guinea to the Solomon Islands but not yet to other island nations of the Pacific, although a suitable vector, *Culicoides brevitarsis*, has reached as far east as Noumea, Fiji and Tonga. The establishment of bluetongue in countries east of Weber's line has depended completely on the previous introduction of ruminants and the presence of cattle-reliant *Culicoides* species which can spread the virus. This sequence has occurred in Australia, Papua New Guinea and the Pacific Islands, where cattle did not exist before being introduced by European settlement.

A change in the interest of Australian veterinary authorities toward bluetongue followed a major epidemic in Merino sheep in the Iberian peninsula in 1956. As the disease existed in the eastern Mediterranean and the United States, it was clear that bluetongue was present close to all the shipping routes from countries that were Australia's sources of improved breeding cattle, sheep and goats. Thus all commercial vessels would pass close to infected regions or call at ports in countries where the disease was endemic, whether they came via the Suez Canal, around Africa or via the Americas. Air transport of ruminants was not a commercial proposition in the 1950s. Reliable laboratory screening tests did not then exist to detect bluetongue virus (BLU) in sheep or in the inapparent cattle host. Australia was not alone in expecting severe consequences from bluetongue, which gave an appearance of continual spread as more countries reported bluetongue as a new disease, or recognised it as the cause of an existing condition.

## Australian Reaction to the Apparent Expansion of Bluetongue

The Australian reaction to this apparent expansion of bluetongue took several forms. The import of cattle, sheep and other ruminant species, including zoo herbivores, was stopped from most regions of the world for many years. These sanctions were extended to donor animals when methods were developed for the long-term storage of semen (Gee 1975). The restrictive effects on sources of gene plasm for Australia were severe.

## Assistance from Abroad

Preparation was wide-ranging. Steps were taken to familiarise Australian veterinarians with bluetongue disease, to supplement those few who had experience with the disease in Africa. Some were sent to courses on exotic diseases conducted at Grosse Isle, Canada. This meant that experienced diagnostic teams could be sent to any possible outbreak. This precautionary approach has continued up to the present although now training is done within Australia. An extensive

---

\* 15 Tamarix Street, Chapel Hill, Queensland 4069, Australia.

tour of Australia by a group of the world's principal bluetongue experts was sponsored by the Australian Bureau of Animal Health in 1974, culminating in a symposium at the Australian Veterinary Association Conference in Adelaide. Inactivated reagents for the complement fixation test and vaccine seed stocks were prepared in South Africa, and held under secure restrictions in case of an outbreak of bluetongue in Australia.

## Australian Virus and Vector

The major long-term strategy was the development of an Australian capability to isolate viruses and to define the *Culicoides* vector species in Australia. This was undertaken by CSIRO Division of Animal Health and Production as a deliberate long-term policy instituted in the mid-1950s by Drs L.B. Bull and T.S. Gregory. They recognised that there was no significant laboratory capability to deal with the laboratory aspects of exotic virus disease. Foot-and-mouth disease was the more pressing reason for the establishment of modern virology with the appointment of Dr E.L. French and W.A. Snowdon to the CSIRO Parkville Laboratory in Melbourne, but the threat of vector-borne bluetongue was the basic reason for developing the *Culicoides* studies.

A vector study group was created with the object of identifying the vectors of ephemeral fever, a serious arthropod-borne virus infection of cattle. The necessary taxonomy developed for this research was, in fact, preparation for bluetongue or other exotic vector-borne disease. The entomology was established within CSIRO by M.D. Murray, A.L. Dyce, H.A. Standfast and M.J. Muller (Muller 1995). By 1977, this team had defined most of the major and minor species of *Culicoides* feeding on cattle and sheep in Australia. The most important of the potential vectors of bluetongue were found to be species linked biologically to cattle as a food source and to cattle dung for breeding sites. These species had become established in Australia from Asia after cattle and buffalo were introduced to northern Australia.

A multidisciplinary team based in Sydney and Brisbane made headway in defining the biology of *Culicoides* species later found to be vectors of bluetongue and related viruses. Vector control plans by aerial and ground disinsection were produced in case of an outbreak of bluetongue but were never used.

In 1968, a network of sentinel cattle had been established (St. George 1980) so that recently collected serum samples were available from cattle in most major regions of Australia, as well as those stored as a library at CSIRO Long Pocket Laboratories since the inception of the system in 1969. By 1977, a system of co-located insect vector traps to

monitor populations was being developed (St. George and Standfast 1983) and mechanisms were in place for rapid expansion. As is amply demonstrated in these Proceedings, this team approach has since served as a model for studying vector-borne viruses of livestock in Southeast Asia.

The final and precipitating event in the bluetongue preparatory period was a continuous study over several months in the subcoastal plains region of the Northern Territory at Beatrice Hill (Standfast et al. 1984). Although the aim of this study was to find the maintenance focus of ephemeral fever virus, techniques for the isolation of viruses from solely mouse brain injection were altered in April 1975 to cater for the entry of bluetongue.

## Discovery of Bluetongue in Australia

### Infection and disease

Despite all the preparation described above, the recognition of bluetongue in Australia in October 1977 (St. George et al. 1978) was only accepted with difficulty by some individuals and organisations. Transmission studies in sheep at CSIRO Long Pocket Laboratories were carried out promptly in a newly-commissioned arthropod-proof building. The fever, disability and lesions observed were typical of bluetongue, though there were no fatalities (St. George and McCaughan 1979; Uren and Squire 1982). However, only laboratory-adapted virus was available so the true potential could not be tested.

An enormous cooperative effort between CSIRO and the respective Departments of Agriculture or Primary Industries of the States and Territories of Australia and Papua New Guinea placed the discovery in context within a few months. The first bluetongue virus (BLU20) had a very limited distribution in far northern Australia, with a probable time of entry into Australia of 1973. The existence of additional bluetongue serotypes was suspected in early November 1977. The evidence was strengthened when seroconversion to BLU1 was demonstrated at Pirbright Laboratory, England, using suitable paired sera from sentinel cattle (Snowdon and Gee 1978). The BLU group antibody, detected by agar gel immunodiffusion (AGID), was much more widely distributed than the neutralising antibody specific to BLU20: it extended into Western Australia, Queensland and New South Wales (Della-Porta et al. 1983), approximating the distribution of *Culicoides brevitarsis*.

Most of the bluetongue group antibody activity was explained by the isolation in 1979, after a deliberate search by sentinel herd techniques, of two further bluetongue viruses (BLU1 and 21). These viruses were used for retrospective serology (Figs 1 and 2) and, as shown in Table 1, their presence was

traced back to at least 1958 (St. George et al. 1980). However, the AGID test was found not to be limited to BLU antibodies: the isolation of five viruses of the epizootic hemorrhagic disease (EHD) group enabled many more of the anomalous serological reactions to be explained (St. George et al. 1983).

The southern limits of the distribution of antibodies detected in surveys using Australian bluetongue and related orbiviruses were approximately reciprocal to those of the Australian commercial sheep flock. This

also approximated the distribution of *Culicoides brevitarsis*, which was later found to be an inefficient BLU vector (St. George and Muller 1984; Standfast et al. 1985, 1992). Although six other species of *Culicoides* were found experimentally to be possible BLU vectors (Standfast et al. 1985), *C. brevitarsis* is the species that most closely impinged on the sheep raising areas. BLU1 has been isolated from 'wild caught' *C. brevitarsis* and *C. fulvus* (Standfast et al. 1979; St. George and Muller 1984).

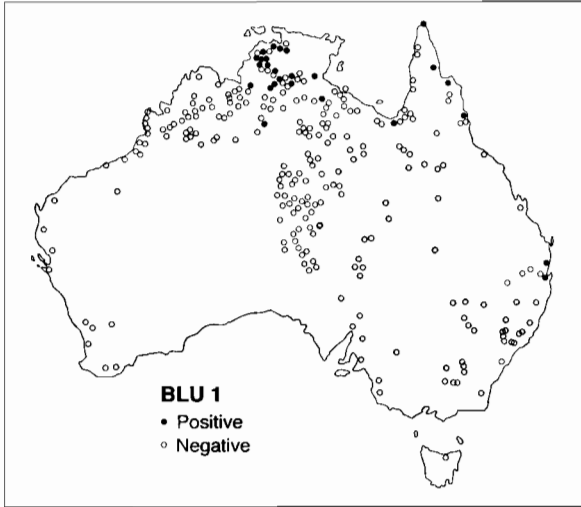

**Figure 1.** The distribution of neutralising antibodies to BLU1 in sera collected from cattle between November 1977 and January 1978.

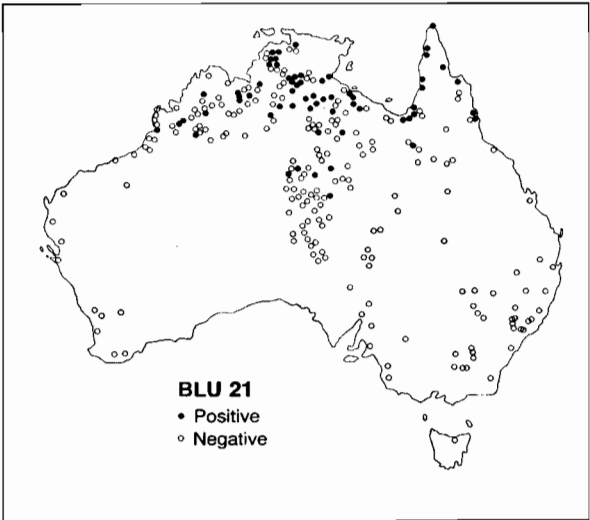

**Figure 2.** The distribution of neutralising antibodies to BLU21 in sera collected from cattle between November 1977 and January 1978.



**Table 1.** Chronology of discovery and retrospective serology of bluetongue viruses (BLU) in Australia.

BLU Serotype	Year of first isolation	Most recent isolation	Year when antibody first detected in cattle	Test in sheep
20	1975	1995	1973	virulent
1	1979	1994	1958	mild
21	1979	1994	1958	mild
15	1982	1986	1980	virulent
23	1982	1989	1974	virulent
9	1985	1986	1985	non-pathogenic
3	1986	1991	1986	virulent
16	1986	1986	1984	virulent

Van Kammen and Cybinski (1981) found BLU antibodies in cattle in Papua New Guinea. In a further search for the source of the new BLU, ruminant sera were obtained from Indonesia and Malaysia in cooperation with those countries where AGID testing had shown the presence of bluetongue group antibody (Geering and Gard 1989). However, using the combined evidence of both virus isolations and *Culicoides* species biology and distribution, Indonesia was the most probable source of Australia's bluetongue viruses (St. George 1986). This conclusion is supported by the finding of bluetongue viruses and antibodies in Indonesian cattle (Sendow et al. 1989, 1993).

By 1981, after the initial delineation of the distribution of BLU and their vectors, it was widely assumed that a steady state existed. *Culicoides brevitarsis* was endemic mainly in the north of Australia and on the east coast, and infested the main sheep-raising areas only marginally and irregularly (Murray 1986). Direct field evidence to confirm that *C. brevitarsis* was infected with BLU did not emerge until later (St. George and Muller 1984).

Under experimental conditions, the first three BLU serotypes had produced moderate illness but no fatalities (Uren and Squire 1982). The isolation of further serotypes between 1982 and 1986 (Table 1), in a new virological unit in Darwin under G.P. Gard, did not attract much attention, despite serological evidence of recent entry (Gard et al. 1985, 1987a, 1987b; Gard and Melville 1989, 1992). The rapid southward expansion of *C. wadai*, a more efficient BLU vector than *C. brevitarsis* (Standfast et al. 1983) was checked by a long succession of dry summers (Muller 1995). CSIRO funds and staff were redirected to other research as the threat of vector expansion was not considered important.

Subsequently, two events altered this perception. First, an experimental demonstration in 1988 showed that four Australian serotypes could cause disease (Johnson et al. 1989). Second, there was a severe clinical case due to natural disease acquired in the

first few days of February 1989 in a sentinel sheep near Darwin (L.F. Melville, pers. comm.). Together with the demand for up-to-date information by customer countries to verify the freedom of much of Australia from bluetongue, these events stimulated a new approach. There was a need to reinstate the surveillance of the distribution of known BLU serotypes and vectors to give warning of threat. Data were also needed on the vaccine potential of Australian BLU, and their persistence in blood and semen.

The capacity to detect both new BLU incursions into Australia and extensions of its range within Australia have changed considerably since 1977, when the delay was some 31 months. Now various state laboratories carry out serology and can isolate BLU. The fatal clinical case near Darwin was diagnosed on 9 Feb 1989, the provisional identity of the causative virus was known on 13 February, and formal identification of BLU23 was made at Berrimah Laboratory on 11 March (L.F. Melville, pers. comm.). The development of molecular techniques means that the initial identification process can be carried out even more quickly in future, using field material directly and with a result in one to two days. These advances mean the protracted delays in the identification of the original Australian BLU isolate need not occur again.

#### Control strategies from 1977 to 1996

Geering (1975) described the anticipated strategies to control bluetongue if it entered Australia. The planned actions included a slaughter out policy of ruminants within a five mile radius, movement controls and disinsection by air and ground application of insecticides to suppress *Culicoides*.

The information available to the regulatory authorities at their first meeting was confined to where and when the insects were caught that had yielded the first BLU isolates. Office International des Epizooties (OIE) and customer countries were advised immediately of the presence of bluetongue in Australia.

The research program progressively provided more information. The planned slaughter out policy and disinsection were never put in place as they were completely inappropriate.

Movement controls on cattle, sheep and buffalo were imposed by various states: these either prohibited or restricted cattle movements north of latitude 18°S. The necessity to protect overseas markets for live animals and products overrode detached scientific judgement on the possible effectiveness of such controls. Prohibitions by importing countries affected not only live cattle, sheep and other ruminants but also germplasm, meat hides and wool, either from bluetongue infected areas or from the whole of Australia. Of necessity, the emphasis changed gradually from detecting infection to defining which parts of Australia were not infected with BLU. This attitude applies even more strongly in 1995, when proof of regional freedom from a disease is becoming an international marketing tool.

Movement controls within Australia, which did not begin to be relaxed until late 1978, took some time to disappear, and even longer for the export trade (Geering and Gard 1989). Rapidly developed serological tests provided data on which to base decisions about movements. Unfortunately, at that time the presence of BLU antibodies was equated to lifelong infection, and many uninfected animals were excluded. Even the accumulating evidence to the contrary is still slow to change this attitude. There is no evidence that movement controls had any beneficial effect whatsoever on limiting the spread of bluetongue to vector-free regions.

In 1981, Australian live sheep shipments became infected with bluetongue after arrival in Indonesia (Sendow et al. 1989) and in 1987 Malaysia (Geering and Gard 1989). These sheep originated from bluetongue-free areas. In the early 1990s sheep were also diagnosed as having bluetongue on arrival in Middle-East countries. However, again the available data indicated that these sheep had originated from bluetongue-free areas within Australia and could not have had bluetongue.

The first three Australian BLU serotypes differed biochemically from the South African ones, indicating genetic diversity (Gorman et al. 1982). Extensive studies at CSIRO Australian Animal Health Laboratories have since confirmed that Australian BLU are more closely related to each other than to South African or American BLU, though structurally identical (Gould et al. 1986, 1989). The earlier decision not to release new BLU genes into the Australian environment by using South African live virus vaccines was thus justified. Vaccine seed stocks of Australian origin (BLU1, 20 and 21) were prepared under security (Wark et al. 1982); subsequently these have included all five serotypes.

Two further events, however, demonstrated that bluetongue was still a threat. The first was a series of experiments in 1988 at Ooonooba Laboratory, Townsville, using unadapted bluetongue field or 'wild' viruses. These experiments clearly showed that strains of BLU3, 15, 16 and 23 were highly virulent to Merino sheep, giving clinical signs equivalent to those seen with the most severe bluetongue and causing 8–32% mortality (Johnson et al. 1992a, b). D. Hoffmann and S.J. Johnson developed one of the most reliable procedures for producing severe clinical bluetongue in the world, which is also used by L.F. Melville. The second event was the occurrence of a naturally-acquired fatal bluetongue disease in a sheep near Darwin in 1989.

### Bluetongue research management

A Bluetongue Research Management Committee, headed by G.I. Alexander, was established by the Australian Agricultural Council and reported on research from 1989 to 1994 (Alexander 1990, 1991). The achievements in this era clarified the different effects of 'wild' bluetongue virus in blood from naturally infected animals and laboratory-adapted virus.

In contrast to the unmodified 'wild' virus, virus adapted in tissue cultures to a vaccine standard became teratogenic to first and second trimester pregnant ewes (Johnson et al. 1992b). Also 'wild' virus, whether naturally acquired (Melville et al. 1993) or injected experimentally, was not excreted in the semen of bulls. However, adapted virus was excreted in the semen of older bulls, possibly due to contamination of semen with red blood cells in the viraemic period. Contamination of semen with BLU during natural infection seems to be a very uncommon event. This has implications for the use of live virus vaccines. The modified virus, which has acquired the undesirable characteristics of teratogenesis and excretion in semen of bulls and rams, has the potential to become established in nature. H.A. Standfast (pers. comm.) and I have shown that even low titre, tissue culture-adapted virus  $10^{2.3}/\text{mL}$  can be taken up by *C. brevitarsis*.

In field trials, Muller and Harris (1993) found that local populations of *C. brevitarsis* could be suppressed by injecting cattle with Ivermectin. This approach is more effective than treating sheep as there is suppression of the larval stage of the life cycle by rendering the cattle dung toxic.

The vaccine options live attenuated, killed whole virus and subunit vaccines were examined by the management committee. The advantages, disadvantages and cost options for each type of vaccine, and for a vaccine bank, were examined. The time frames to produce each type of vaccine were also delineated (Alexander et al. 1993). Further development of

whole virus, chemically-inactivated, and sub-unit vaccines were deemed necessary before definitive recommendations could be justified.

## Indonesia, Papua New Guinea, Solomon Islands, New Caledonia, Fiji and Tonga

The source of BLU that periodically enter the north-west of the Northern Territory is now certainly Indonesia, from the evidence of the isolation of BLU serotypes and the vector identifications presented in these Proceedings. Evidence of the presence of many other arboviruses found in the same vectors is steadily accumulating. Probably all BLU serotypes that have been isolated in northern Australia will be found in Indonesia in due course. *Culicoides brevitarsis* carries many other arboviruses that infect cattle. Of the 17 viruses of the Simbu, Palyam and ephemeral fever group, of which *C. brevitarsis* is the proven or suspected vector in Australia, many are known from Indonesia from virus isolation or serological surveys, eight are present in New Guinea, seven in the Solomon Islands, three in New Caledonia and one in Fiji.

The cattle in Papua New Guinea have fewer BLU serotypes than cattle in Australia and there is only a single serotype in the Solomon Islands. New Caledonia and Fiji had no bluetongue in 1987. *C. brevitarsis* has colonised these islands and Tonga, so the potential remains for spread if bluetongue viruses were introduced in infected *Culicoides* blown in on the wind. The range of *Culicoides* species linked to cattle is greatest in Indonesia, with fewer in Papua New Guinea and Australia, and probably only a single species in Noumea and Fiji (Dyce 1982). New Zealand is presently free of both *C. brevitarsis* and the viruses it can spread.

There is thus a gradient in the number of arboviruses carried by *Culicoides* from west to east and in the number of arbovirus-carrying species that feed on ruminants. Large distances across the sea seem to be less of a barrier to the passive movement of insects than was thought in the past.

## Lessons from History

The announcement that bluetongue was present in Australia caused a severe economic impact by halting interstate movement of cattle and live exports for months, even though the virus did not kill a single sheep. Also, it had been implicitly assumed that other countries had the same knowledge of how to limit the spread of an arthropod-borne virus as had been developed in Australia as a result of systematic preparation. Any initial announcement regarding bluetongue must be followed up by relaying information as it

becomes available, preferably in the language of importing countries, in case scientific data are not available there.

Before bluetongue was discovered in Australia its threat was considered to be linked to the importation of animals and germplasm from Europe and North America. It is now known that BLU and its vectors are merely part of the movement of a wide range of arboviruses and insect vectors expanding from the islands of Southeast Asia to the Pacific (St. George 1986, 1992). In contrast to most of the tropical and subtropical world, bluetongue is an emerging disease in Australia, Papua New Guinea and the Pacific islands.

The current Australian Veterinary Plan for bluetongue, developed in 1994, depends heavily on continued surveillance to give warning, but the capacity to deal with an outbreak or an epidemic is limited to suppression of *Culicoides* vectors by treatment of cattle and sheep with Ivermectin (Muller and Harris 1993). Until a non-living, broad spectrum vaccine is available, the Australian commercial sheep flock remains as vulnerable as it was in 1977.

## References

- Alexander, G.I. 1990. Bluetongue in Australia. *Australian Veterinary Journal*, 67, 277.
- 1991. Bluetongue research in Australia 1990. *Australian Veterinary Journal*, 68, 125–126.
- Alexander, G.I., St. George, T.D. and Gard, G.P. 1993. Report on bluetongue vaccines to Australian Meat Corporation, Sydney.
- Della-Porta, A.J., Sellers, R.F., Herniman, K.A.J., Littlejohns, I.R., Cybinski, D.H., St. George, T.D., McPhee, D.A., Snowdon, W.A., Campbell, J., Cargill, C., Corbould, A., Chung, Y.S. and Smith, V.W. 1983. Serological studies of Australian and Papua New Guinea cattle and Australian sheep for the presence of antibodies against Australian bluetongue group viruses. *Veterinary Microbiology*, 8, 147–162.
- Dyce, A.L. 1982. Distribution of *Culicoides Avaritia* spp (Diptera: Ceratopogonidae) west of the Pacific Ocean. In: St. George, T.D. and Kay, B.H. ed., *Arbovirus research in Australia. Proceedings 3rd Symposium. CSIRO/Queensland Institute of Medical Research, Brisbane*, 35–43.
- Gard, G.P. and Melville, L.F. 1989. The evolution of bluetongue in northern Australia. In: Uren, M.F., Blok, J. and Manderson, L.H., ed., *Arbovirus research in Australia. Proceedings 5th Symposium. CSIRO/Queensland Institute of Medical Research, Brisbane*, 303–305.
- 1992. Results of a decade's monitoring for orbiviruses in sentinel cattle pastured in an area of regular arbovirus activity in northern Australia. In: Walton, T.E. and Osburn, B.I. ed., *Bluetongue, African horse sickness and related orbiviruses. Proceedings 2nd International Symposium. CRC Press, Boca Raton*, 85–92.

- Gard, G.P., Shorthose, J.E., Cybinski, D.H. and Zakrzewski, H. 1985. The isolation from cattle of 2 bluetongue viruses new to Australia. *Australian Veterinary Journal*, 62, 203.
- Gard, G.P., Shorthose, J.E., Weir, R.P. and Erasmus, B.J. 1987a. The isolation of a bluetongue serotype new to Australia. *Australian Veterinary Journal*, 64, 87–88.
- Gard, G.P., Weir, R.P., Melville, L.F. and Lunt, R.A. 1987b. The isolation of bluetongue virus type 3 and 16 from northern Australia. *Australian Veterinary Journal*, 64, 388.
- Gee, R.W. 1975. Bluetongue certification Australian policy. *Australian Veterinary Journal* 51, 213–215.
- Geering, W.A. 1975. Control of bluetongue in an epizootic situation. *Australian Veterinary Journal* 51, 220–224.
- Geering, W.A. and Gard, G.P. 1989. Bluetongue infection of sheep in Malaysia. In: Uren, M.F., Blok, J. and Manderson, L.H., ed., *Arbovirus research in Australia*. Proceedings 5th Symposium. CSIRO/Queensland Institute of Medical Research, Brisbane, 310–311.
- Gorman, B.M., Taylor, J., Finnimore, P.M., Bryant, J.A., Sangar, D.V. and Brown, F. 1982. A comparison of bluetongue viruses isolated in Australia with exotic bluetongue virus serotypes. In: St. George, T.D. and Kay, B.H., ed., *Arbovirus research in Australia*. Proceedings 3rd Symposium. CSIRO/Queensland Institute of Medical Research, Brisbane, 101–109.
- Gould, A.R. and Eaton, B.T. 1986. Genotype variants of Australian orbiviruses. In: St. George, T.D., Kay, B.H. and Blok, J., ed., *Arbovirus research in Australia*. Proceedings 4th Symposium. CSIRO/Queensland Institute of Medical Research, Brisbane, 253–258.
- Gould, A.R., Hyatt, A.D., Eaton, B.T., White, J.R., Hooper, P.T., Blacksell, S.D. and Le Blanc Smith, P.M. 1989. Current techniques in rapid bluetongue diagnosis. *Australian Veterinary Journal*, 66, 450–454.
- Johnson, S.J., Hoffmann, D., Flanagan, M., Polkinghorne, I.G. and Bellis, G.A. 1989. Recent experience with bluetongue in Queensland. In: Uren, M.F., Blok, J. and Manderson, L.H., ed., *Arbovirus research in Australia*. Proceedings 5th Symposium. CSIRO/Queensland Institute of Medical Research, Brisbane, 307.
- Johnson, S.J., Polkinghorne, I.G., Flanagan, I.M. and Townsend, W.L. 1992a. Clinicopathology of Australian bluetongue virus serotypes for sheep. In: Walton, T.E. and Osburn, B.I., ed., *Bluetongue, African horse sickness and related orbiviruses*. Proceedings 2nd International Symposium, CRC Press, Boca Raton, 737–743.
- 1992b. The Australian experience: results of a bluetongue vaccination program. In: Walton, T.E. and Osburn, B.I., ed., *Bluetongue, African horse sickness and related orbiviruses*. Proceedings 2nd International Symposium, CRC Press, Boca Raton, 868–873.
- Melville, L.F., Kirkland, P.D., Hunt, N.T. and Williams, C.F. 1993. Excretion of bluetongue virus serotypes 1 and 23 in semen of bulls. In: St. George, T.D., Kay, B.H., and Blok, J., ed., *Arbovirus research in Australia*. Proceedings 6th Symposium. CSIRO/Queensland Institute of Medical Research, Brisbane, 185–187.
- Muller, M.J. 1995. Veterinary arbovirus vectors in Australia a retrospective. *Veterinary Microbiology*, 46, 101–116.
- Muller, M.J. and Harris, E.J. 1993. The use of a systemic insecticide to control the arbovirus vector *Culicoides brevitarsis*. In: Uren, M.F. and Kay, B.H., ed., *Arbovirus research in Australia*. Proceedings 6th Symposium. CSIRO/Queensland Institute of Medical Research, Brisbane, 23–27.
- Murray, M.D. 1986. The influence of abundance and dispersal of *Culicoides* on the epidemiology of arboviruses of livestock in New South Wales. In: St. George, T.D., Kay, B.H. and Blok, J., ed., *Arbovirus research in Australia*. Proceedings 4th Symposium. CSIRO/Queensland Institute of Medical Research, Brisbane, 232–234.
- Sendow, I., Daniels, P., Soleha, E., Hunt, N.T., Bole, A. and Ronohardjo, P. 1989. Studies on orbiviral infections of sentinel ruminants in Indonesia. In: Uren, M.F., Blok, J. and Manderson, L.H., ed., *Arbovirus research in Australia*. Proceedings 5th Symposium. CSIRO/Queensland Institute of Medical Research, Brisbane, 311–315.
- Sendow, I., Soleha, E., Daniels, P.W. and Sukarsih. 1993. Serological studies of bluetongue virus in Indonesia. In: St. George, T.D., Kay, B.H. and Blok, J., ed., *Arbovirus research in Australia*. Proceedings 4th Symposium. CSIRO/Queensland Institute of Medical Research, Brisbane, 271–273.
- Snowdon, W.A. and Gee, W. 1978. Bluetongue virus in Australia. *Australian Veterinary Journal*, 54, 505.
- Standfast, H.A., Dyce, A.L. and Muller, M.J. 1985. Vectors of bluetongue virus in Australia. In: Barber, T.C., Jochim, M.S. and Osburn, B.I. ed., *Bluetongue and related orbiviruses*. Progress in Clinical and Biological Research, vol. 178, Alan R. Liss Inc., New York, 177–186.
- Standfast, H.A., Dyce, A.L., St. George, T.D., Cybinski, D.H. and Muller, M.J. 1979. Vectors of a bluetongue virus in Australia. In: St. George, T.D. and French, E.L. ed., *Arbovirus research in Australia*. Proceedings 2nd Symposium. CSIRO/Queensland Institute of Medical Research, Brisbane, 20–28.
- Standfast, H.A., Dyce, A.L., St. George, T.D., Muller, M.J., Doherty, R.L., Carley, J.G. and Filippich, C. 1984. Isolation of arboviruses from insects collected at Beatrice Hill, Northern Territory of Australia, 1974–1976. *Australian Journal of Biological Sciences*, 37, 351–366.
- Standfast, H.A., Muller, M.J. and Dyce, A.L. 1983. A recent extension of the range of *Culicoides wadai* to south-east Queensland. *Australian Veterinary Journal*, 60, 383–384.
- 1992. An overview of bluetongue virus vector biology and ecology in the oriental and Australasian regions of the western Pacific. In: Walton, T.E. and Osburn, B.I., ed., *Bluetongue, African horse sickness and related orbiviruses*. Proceedings 2nd International Symposium. CRC Press, Boca Raton, 253–261.
- St. George, T.D. 1980. A sentinel herd system for the study of arbovirus infections in Australia and Papua New Guinea. *Veterinary Science Communications*, 4, 39–51.
- 1986. Arboviruses infecting livestock in the Australian Region. In: St. George, T.D., Kay, B.H. and Blok, J., ed., *Arbovirus research in Australia*. Proceedings 4th Symposium. CSIRO/Queensland Institute of Medical Research, Brisbane, 23–25.
- 1992. Occupation of an ecological niche in the Pacific Ocean countries by bluetongue and related viruses. In: Walton, T.E. and Osburn, B.I., ed., *Bluetongue, African horse sickness and related orbiviruses*. Proceedings 2nd International Symposium. CRC Press, Boca Raton, 76–84.

- St. George, T.D., Cybinski, D.H., Della-Porta, A.J., McPhee, D.A., Wark, M.C. and Bainbridge, M.H. 1980. The isolation of two bluetongue viruses from healthy cattle in Australia. *Australian Veterinary Journal*, 56, 562 - 563.
- St. George, T.D., Cybinski, D.H. and Standfast, H.A. 1983. The isolation of five different viruses of the epizootic hemorrhagic disease of deer. *Australian Veterinary Journal*, 60, 216-217.
- St. George, T.D. and McCaughan, C.J. 1979. The transmission of the CSIRO19 strain of bluetongue virus type 20 to sheep and cattle. *Australian Veterinary Journal* 55, 198-199.
- St. George, T.D. and Muller, M.J. 1984. The isolation of a bluetongue virus from *Culicoides brevitarsis*. *Australian Veterinary Journal* 61, 95.
- St. George, T.D. and Standfast, H.A. 1983. Bovine ephemeral fever in north Queensland 1974-1977. Queensland Department of Primary Industries Bulletin, Brisbane, QB83001, 9.
- St. George, T.D., Standfast, H.A., Cybinski, D.H., Dyce, A.L., Muller, M.J., Doherty, R.L., Carley, J.G., Filippich, C. and Frazier, C.L. 1978. The isolation of a bluetongue virus from *Culicoides* collected in the Northern Territory of Australia. *Australian Veterinary Journal*, 54, 53-54.
- Uren, M.F. and Squire, K.R.E. 1982. The clinico-pathological effect of bluetongue virus serotype 20 in sheep. *Australian Veterinary Journal*, 58, 11-15.
- Van Kammen, A. and Cybinski, D.H. 1981. A serological survey for antibodies to bluetongue virus in Papua New Guinea. *Australian Veterinary Journal*, 57, 253-255.
- Wark, M.C., Shepherd-Clark, M.B., Smith, H.V. and Collins, W.D. 1982. Laboratory evaluation of a living attenuated vaccine against bluetongue type 20 virus. *Australian Veterinary Journal*, 59, 6.

# Bluetongue Virus Status in Papua New Guinea

I. Puana\*

## *Abstract*

At about the same time (1977–78) that Australia was conducting a massive serological survey for bluetongue virus, after the isolation of the CSIRO 19 strain (BLU20), a similar but smaller-scale survey was being carried out in Papua New Guinea. At the National Veterinary Laboratory, group-specific testing by agar gel immunodiffusion (AGID) of both survey sera and stored sera dating back as far as 1974 demonstrated seroconversion in cattle, deer, goats, buffalo and sheep. Subsequent type-specific serum neutralisation tests demonstrated positives in buffalo for CSIRO 19 (BLU20), and in cattle for CSIRO 154 (BLU21) and CSIRO 156 (BLU1). In Papua New Guinea, BLU2 to BLU17 and BLU20 have never been recorded in any ruminants. In 1989, the Northern Australian Quarantine Strategy surveillance and monitoring of sentinel herds and border surveys was established in Papua New Guinea in cooperation with Australia. So far, neither border surveys near Irian Jaya in 1991, 1992 and 1993, nor sentinel herd sera sampled up to 1994, have detected seroconversion in sheep.

---

\* Agricultural Protection Division, Department of Agriculture and Livestock, PO Box 2141, Boroko, Papua New Guinea.

# An Outbreak of Bluetongue in Cattle in Japan

Y. Goto, M. Yamakawa and Y. Miura\*

## *Abstract*

An outbreak of Ibaraki-like disease swept over the eastern parts of Japan between August and the end of October 1994. The clinical and pathological findings were very reminiscent of Ibaraki disease. The pathological changes were confined to the mucous membrane of the digestive tract and its musculature, with the lesions being essentially hyperaemic. The most conspicuous changes were in the oesophagus, larynx and pharynx with degeneration of striated muscle. An attempt to isolate the causative virus directly in HmLu-1 or BHK21 cells failed. Bluetongue viral RNA was detected in blood samples from affected cattle by polymerase chain reaction (PCR) tests, carried out by the method of McColl and others. Antibodies to bluetongue group virus were detected in the serum of all affected cattle. However, all sera were negative for Chuzan virus while a few had antibodies to Ibaraki virus. In the epidemic area, bluetongue antibodies, as determined by agar gel immunodiffusion (AGID) were detected at a high prevalence, whereas they were found in few or none of the serum samples collected in non-epidemic areas. Among the animals, there was a correlation between bluetongue infection and difficulty in swallowing.

---

\* National Institute of Animal Health, 1-1 Kannondai 3-chome, Tsukuba-shi, Ibaraki-ken, 305 Japan.

# Bluetongue History, Serology and Virus Isolation in China

Zhang Nianzu, Li Zhihua, Zhang Khaili, Hu Yuling, Li Gen, Peng Kegao,  
Li Huachun, Zhang Fuqiang, Ben Jin, Li Xinrong,  
Zhou Fuzhong and Liu Gui\*

## Abstract

This paper reports the history of bluetongue disease, serology and virus isolation in China. Bluetongue disease was first diagnosed in Yunnan Province in 1979, an event which initiated bluetongue research in China. Extensive serological surveys were carried out among domestic animals such as sheep, goats and buffalo, using agar gel immunodiffusion (AGID). Antibodies have been found in most animals in most provinces, while clinical bluetongue has occurred in six provinces. Strains of bluetongue virus have been isolated from sheep, goats or *Culicoides* midges in Yunnan, Hubei, Sichuan, Shanxi, Shandong and Gansu Provinces, and in Xinjiang and Inner Mongolia.

BLUETONGUE is an infectious, non-contagious, arthropod-borne viral disease, transmitted by midges of the genus *Culicoides* which feed on sheep as well as other ruminants. Bluetongue disease has had an epidemic history on the African continent since 1852, when Merino and other European sheep were imported to South Africa. The history of bluetongue as a distinct entity in the veterinary world spans the past hundred years (as described elsewhere in these Proceedings). The presence of bluetongue in China was not confirmed until 1979. This paper reports the history, serology and isolation of bluetongue virus (BLU) in China.

## The Discovery and Diagnosis of Bluetongue in Yunnan Province

In May 1979, there was an outbreak of a bluetongue-like disease in the sheep farms of Shizong county and the surrounding area in the Qujing region of Yunnan Province. The investigation and study of bluetongue in China began shortly thereafter, in July 1979.

## Epidemiological Survey

### Natural environment of the area and brief epidemiology

Shizong County, the epidemic area, is located in a mountainous region in the eastern part of Yunnan, at 24°40'N, 104°11'E. The average altitude is 1987 m above sea level, although the surrounding area ranges from 1750 m to 2000 m. The four seasons are not clearly defined but there are obvious dry and wet seasons each year. According to (incomplete) climate records, the average annual temperature is 10.5°C, with an average maximum of 26.4°C in May and an average minimum of -1.4°C in January. The average relative humidity is 71.2%, with general average precipitation of 1465.8 mm per year. On the grazing area of some 6070 hectares, the majority of livestock are ruminants (1206 sheep, 483 goats, 559 cattle and buffalo, and a few horses and pigs).

The first outbreak of bluetongue occurred in two flocks of sheep on Shizong Farm, followed by outbreaks in three flocks of sheep in neighbouring villages. Of a total of 1206 sheep at risk in the five epidemic sites, 430 (35.7%) became sick, and 170 (31.9%) of these died. One sick goat was also suspected to have bluetongue. No other ruminants on the farm were affected.

\* Yunnan Tropical and Subtropical Animal Virus Diseases Laboratory, Jindian 650224, Kunming, People's Republic of China.



## Analysis of the disease's origin

Sheep have been kept on the Shizong farm since 1958. Although some regional breeds had been introduced (including Xinjing and Caucasus breeds from Gongnaisi, Xinjing and the Yunnan Provincial Farm, and Australian breeds such as Polwarth and Romney introduced through Xundian farm in 1977; Table 1), there was no significant relationship between the introduced breeds and the incidence of bluetongue. There were fragmentary reports about suspected cases in 1966 but no detailed records. The first infection was identified in July 1974. From 1974 to 1977 only four sheep died out of 10 that were ill (Table 2). In May 1978 there was an acute outbreak of bluetongue. While the origin of the disease on Shizong Farm is not clear, the other epidemic sites had either taken sheep from Shizong Farm or had crossgrazed flocks of sheep within the farms themselves. For example, 46 sheep were introduced from Shizong Farm to the Tuoluo village of Longqing Primitive Commune in May 1980. Subsequently, sick sheep were found in local flocks. There was a higher mortality rate among local sheep than among introduced animals.

## Susceptible animals

In Yunnan, only sheep are susceptible to bluetongue. The survey in Shizong county showed differences in the breeds, age and gender of infected animals: the latter comprised 69% (101/146) of all sheep, 22.6% of lambs aged 6 months to 1 year, and 46.6% of animals aged one to four years (most aged one to two years). The prevalence in Xinjiang sheep was higher than in crossbreeds (Table 3) while the prevalence in females was higher than in males.

## Epidemic season

According to records from the five epidemic areas, the first sheep was diagnosed with bluetongue on 18 May 1978, with the terminal date of epidemic disease

being 14 October 1978, a duration of 150 days. Prevalence was highest at 60.2% in July, with a decline to 33% in August. The mortality rate in the epidemic period was also highest in July at 35.1% (Table 4). Only one sheep relapsed, on 20 February 1980. No incidence or other relapse was found after the outbreak.

**Table 2.** Outbreaks of suspected bluetongue disease, Shizong Farm, 1974-1978.

Epidemic years	No. of sick animals	No. of animals that died	Mortality	Remarks
1974	5	3	3/5	veterinary records
1975	2	1	1/2	from incomplete records 1974
1977	3	1	1/3	no records before 1977
1978	22	6	6/22	from incomplete veterinary records
<b>Total</b>	<b>32</b>	<b>11</b>	<b>11/32</b>	

## Clinical Signs

Through systematic observation of 48 sheep, and more general observations on 144 naturally-infected sheep, the following clinical signs were noted. The initial sign was an elevated body temperature, about 40.5-41.5°C, quite often followed by a greyish-white lesion on the upper gums and corners of the mouth, and oedema of the gums, lips, muzzle and ears. A watery discharge from the nostrils then occurred, becoming mucocatarrhal and hardening to form pinkish crusts.

**Table 1.** Introduction of sheep breeds to Shizong.

Farm	Date	Breed	Source	No. of sheep
Tuoluo village	May 1979	Xinjiang	Shizong 5.7 Farm	46
Longqing Commune	1958	Local	Fuyuan County	358
	1960	Caucasus	Qujing County	20
Shizong Farm	1964	Xinjiang	Xinjiang Gongnaisi Farm	153
	1966	Xinjiang	Xinjiang Gongnaisi Farm	158
	1972	Xinjiang	Xundian Breeding Farm	3
	1972	Caucasus	Xundian Breeding Farm	2
	1977	Xinjiang	Xundian Breeding Farm	2
	1977	Half-Polwarth	Xundian Breeding Farm	1
	1978	Romney	Xundian Breeding Farm	2

**Table 3.** Relationship of morbidity and mortality rates for bluetongue disease with age and breed of sheep.

Breed	Age (years)	No. of sick sheep (%)	No. of sheep that died (%)
Xinjiang	0.5-1	20 (27)	10 (45.4)
	1-2	23 (31)	6 (27.3)
	3-4	17 (22.9)	3 (13.6)
	5-6	9 (12.1)	1 (4.5)
	>7	5 (6.7)	2 (9.1)
	<b>Total</b>		<b>74</b>
Cross-breeds	0.5-1	14 (18.4)	4 (25)
	1-2	28 (36.8)	6 (37.5)
	3-4	16 (21)	3 (18.7)
	5-6	13 (17.1)	2 (12.5)
	>7	5 (6.5)	1 (6.2)
	<b>Total</b>		<b>76</b>
Total	0.5-1	34 (22.6)	14 (36.8)
	1-2	51 (34)	12 (31.6)
	3-4	33 (22.9)	6 (15.8)
	5-6	22 (14.6)	3 (7.9)
	>7	10 (6.6)	3 (7.9)
	<b>Total</b>		<b>150</b>

Sloughing of the epithelium of the inner mouth followed, with anorexia and depression. In some cases diarrhoea occurred, occasionally haemorrhagic. Difficulty in swallowing and aspiration of ruminal contents resulted in the secondary pneumonia that was the proximal cause of death.

In some cases, the skin above the hooves became swollen, hyperaemic and haemorrhagic in the early stages, followed by sloughing of the shell of the hooves. The infected animal became recumbent and was reluctant to rise. Wool condition suffered, with substantial permanent breaks in the fibre and shedding over a wide area of the back and groin, although new wool grew after shedding. Needle-point spots of hyperaemia could be seen on the skin, particularly in the areas of shedding (base of tail, elbow and groin).

Serology tests on 48 sheep showed that there was a significant decrease of leucocytes in the blood: 33/48 declined to 8000/mm<sup>3</sup> (average 6386/mm<sup>3</sup>). The lowest total number of leucocytes was 4150/mm<sup>3</sup>, with 15/48 having counts of 8000-10000/mm<sup>3</sup> (average 10700/mm<sup>3</sup>). The average number of leucocytes of the 48 sheep was 7736/mm<sup>3</sup>, whereas the normal level was 10700/mm<sup>3</sup>. The most obvious decrease of leucocytes occurred in the early stages of infection, but continued in cases of secondary infection.

## Postmortem Examinations

Postmortem examinations were conducted on six of the infected sheep. The major pathological changes associated with bluetongue related to the vascular system. The pathological lesions due to the virus were characteristic of an inflammatory process with increased vascular permeability of the mucous membranes of the digestive tract. Hyperaemia, oedema and haemorrhage were found in mucous membranes in the mouth, with severe lesions in the top of tongue papillae. Whitish pseudo-membranes, from 1-2 cm wide by 3 cm long were found on the upper gums in the mouth: an irregular erosion was seen after the pseudo-membrane was removed. A dried membrane occurred on the muzzle. Viscid reddish-brown secretions were seen around the nose, and erosions and ulcers on the mucosae of the mouth and hard palate. Oedema had developed in the muscles around the throat, and gelatinous infiltration was found in the fatty tissues. Mucosal haemorrhages were seen on the trachea and lungs. A few haemorrhage spots were found on the external cardiac membranes, with speckles of haemorrhage around the ventricle and atrium. The colour of the myocardium varied, the coronary fatty tissue was gelatinous and atrophied, and giant focal haemorrhages were seen in cardiac muscles. Scattered haemorrhages were found on the forestomach (muscular pillars and oesophageal groove). The older haemorrhage spots resembled black sesame seeds. The mucosa of the intestines and forestomachs was haemorrhaged and came off easily. The liver and kidneys were congested.

## Diagnosis

### Sheep inoculation

The first experiment was carried out from 17 to 30 July 1979. Nine healthy animals in three groups were injected with 65-100 mL of whole blood (citric acid anticoagulant) drawn from naturally-infected sheep. The dose was repeated once. Three to five days after the first injection, a slightly elevated body temperature (41-41.5°C) occurred in all animals and lasted for four to six days. Mucosal hyperaemia and oedema were seen in mouth, pillars of the tongue and nostrils, with erosion in the corners of the mouth and a grey-yellowish pseudo-membrane on the tops of ulcers on the upper gums.

The leucocyte counts fell from 7050-14650/mm<sup>3</sup> to 3400-8900/mm<sup>3</sup> from day 3 post-infection. These recovered to normal (before infection) levels from day 5 post-infection. Lymphocytes started to increase from day 3 post-infection. The latent period, clinical signs and clinical serological changes of the later four experiments were basically similar.

**Table 4.** Changes of morbidity and mortality rates of bluetongue disease in sheep during the epidemic season.

Epidemic site	Epidemic month	No. of sick sheep	Morbidity %	No. of dead sheep	Mortality %	Total no. dead/ total no. sick (%)
Xiaofakuai village, Wulong commune	May	0	0	0	0	9/34 (26)
	June	1	3.0	0	0	
	July	9	26.5	4	44.4	
	August	23	67.6	5	55.5	
	September	1	2.9	0	0	
	October	0	0	0	0	
Dachang Village, Wulong commune	May	0	0	0	0	30/74 (41)
	June	0	0	0	0	
	July	44	59.4	20	66.7	
	August	28	37.8	9	30.0	
	September	2	2.7	1	3.3	
	October	0	0	0	0	
Tuoluo village, Longqing commune	May	0	0	0	0	50/160 (31)
	June	0	0	0	0	
	July	89	55.6	30	60.0	
	August	60	37.5	18	36.0	
	September	10	6.25	2	4.0	
	October	1	0.6	0	0	
Shizong Farm	May	1	0.6	0	0	48/162 (30)
	June	8	4.9	1	2.1	
	July	117	72.2	37	77.1	
	August	30	19.1	8	16.7	
	September	4	2.5	2	4.2	
	October	1	0.6	0	0	
Totals	May	1	0.2	0	0	137/430 (32)
	June	9	2.1	1	0.7	
	July	259	60.2	91	66.4	
	August	142	33.0	40	29.2	
	September	17	3.9	5	3.6	
	October	2	0.5	0	0	

### Embryonated egg inoculation

The procedure involved inoculating 8- to 10-day-old embryos with whole blood from 19 natural or artificially infected sheep, blind passaged in embryos. Specimen no. 33 was used for 5-24 blind passages and no. 40 for four blind passages. The others were discarded after between two and ten passages. Specimens nos. 40 and 57 were inoculated into a superficial vein of 11- to 13-day-old embryos and then blind-passaged.

All eggs were incubated at 33.5-34°C for another 4-5 days. The clinical pathological signs in the embryos were the gelatinous infiltration of the embryo, and swelling of the organs such as heart, stomach, spleen and liver, with necrosis of the liver. Death then occurred.

Seventeen sheep were inoculated with emulsion of embryo amnion at F4, F10, F5, F11, F13 from specimen no. 33, F7 from no. 71 and F4 from no. 15 in the

blind passage period. One sheep appeared to have obviously typical bluetongue symptoms, eight had elevated body temperatures and decreased leucocytes, and eight had no symptoms. All animals with clinical or subclinical signs were inoculated with specimen no. 33. Eight sheep were then inoculated with embryo tissues: whole blood, amnion fluid and organs (heart, spleen, liver and kidney). Two animals (sheep 57 and 61) had severe symptoms, one had minor symptoms, another three had slight reactions and the remaining two had no clinical changes. Bluetongue virus was thus isolated from the above experiments with fundamentally similar results.

### Cell Infection

The procedure with baby hamster kidney (BHK) cells was similar with each cell type. The same volume of distilled water as in the original sample was added to

the blood of sheep no. 89 to lyse the red cells. These were then centrifuged at 1000 rpm for 10 min. The supernatant was diluted with Eagle's solution at dilutions of 1/10, 2/10, 3/10 and undiluted. The cells were inoculated with the lysed blood in all dilutions, with one bottle of uninoculated cells kept as a control: all were incubated at 33.5–34.5°C. Cytopathic effects (CPE) occurred at 72 hours after infection in the undiluted group, at 96 hours at the 10<sup>-1</sup> and 10<sup>-2</sup> dilutions, and at 120 hours at the 10<sup>-3</sup> dilution. No CPE was seen in the control cells.

Vero cells were infected with 1/10 and 2/10 dilutions of the third passage from sheep no. 64. The CPE involved cell enlargement and rounding up. The cell boundaries were not clear, and granular spots developed in detached cells. After 72 hours of inoculation, some cells enlarged and a typical CPE was seen after 96 hours in the 1/10 and 2/10 dilutions. Control cells became round due to ageing but did not clump. In

monolayer cells of goat embryo kidney inoculated with blood from sheep no. 64, CPE was seen 120 hours after infection.

### Isolation and Identification of Virus

#### Isolation from naturally-infected animals

After the first isolation of bluetongue virus from Shizong Farm in 1979, an outbreak of sheep disease was reported from Xiangfan region in Hubei Province where 132 sheep out of 150 (88%) became sick and 38 (29%) animals died. Agar gel immunodiffusion (AGID) tests of sera from recovered sheep showed 14/16 (88%) were positive. A successful procedure for virus isolation and identification was developed by Yunnan Animal Husbandry and Veterinary Institute (YAHVI) and the Hubei General Veterinary Station (Fig. 1).

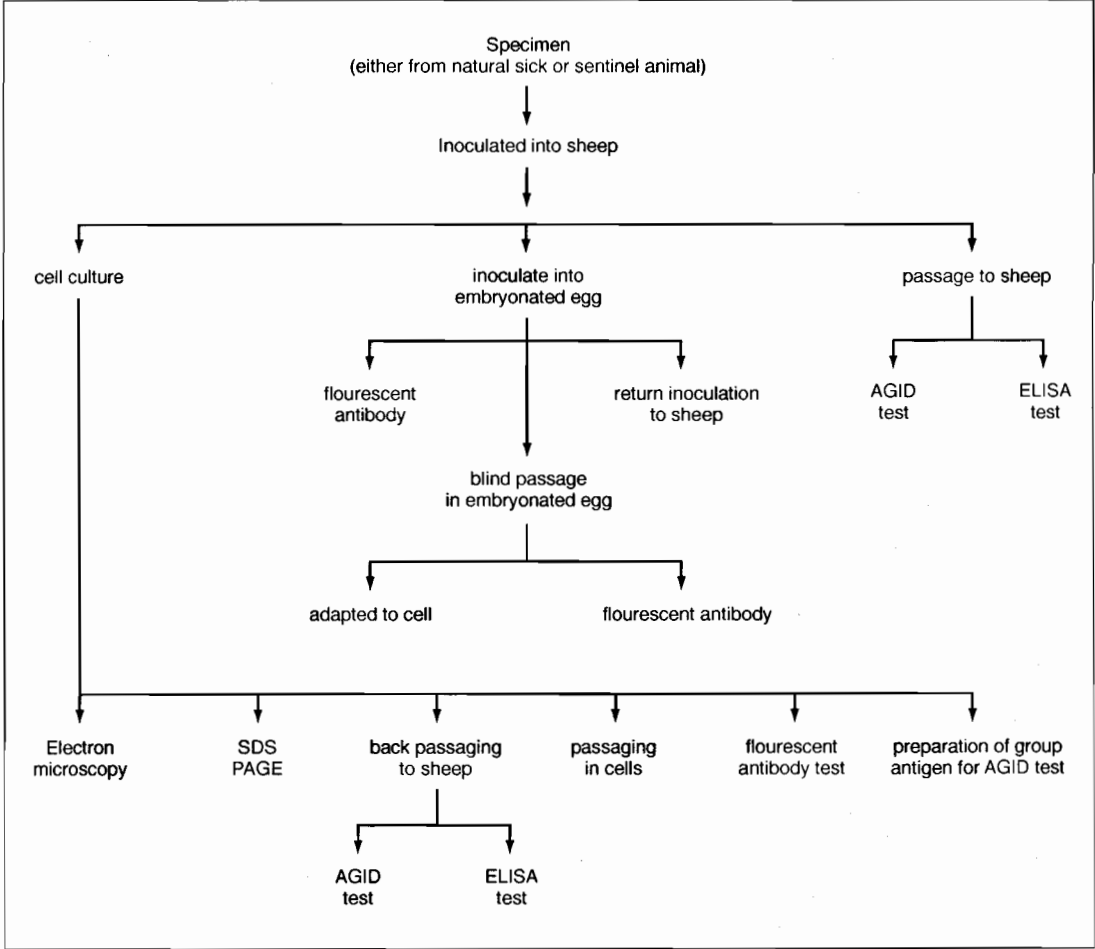
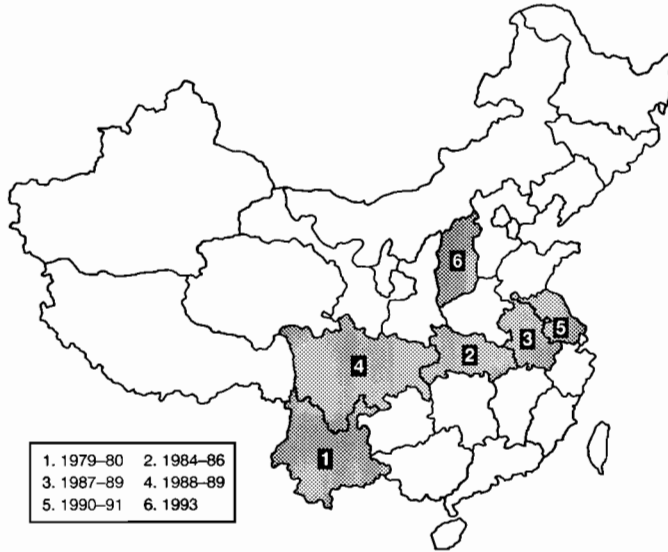

Figure 1. Schema showing procedure used for primary isolation of bluetongue virus in China

Further bluetongue outbreaks occurred from 1987–1993 (Fig. 2). In 1987, some suspected cases were reported by the Sichuan General Veterinary and Prevention Station from a monitoring area in Hongchiba, Wanxian region, where there were no records of bluetongue disease. Hongchiba farm, established in 1958, introduced Ganzi-Tibet, Xinjiang-fine wool and Romney breeds from Jiangsu Province in 1986.

No bluetongue disease was found. However, after the introduction of 691 Xinjiang Merinos there was an outbreak of bluetongue, with an incidence rate of 12.4% and mortality rate of 22%. In 1988, YAHVI and the Chengdu and Wanxian Quarantine Stations isolated BLU from the specimens from sick sheep. Viruses were isolated from specimens from Anhui by National Quarantine and Veterinary Institute (NQVI)



**Figure 2.** Outbreaks of bluetongue disease in sheep in China.

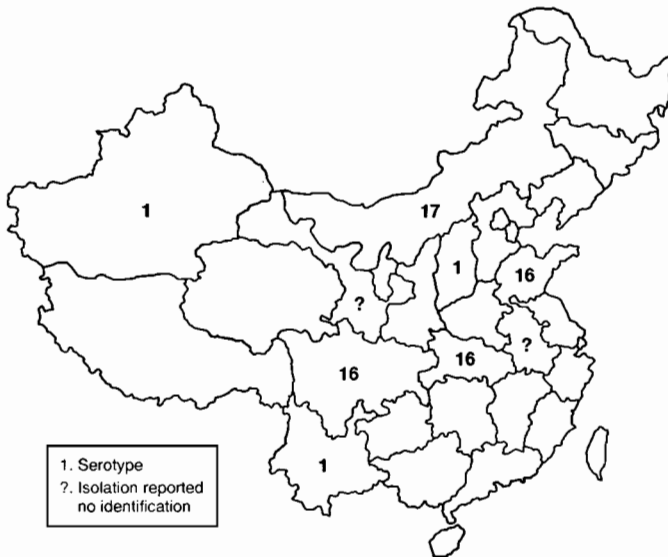

**Figure 3.** Bluetongue virus (BLU) isolations in provinces in China. (BLU - 1, 16, 17; ? - Isolation reported no identification).

in the same year. In 1993, another outbreak of bluetongue occurred in the Jiaocheng region of Shanxi Province, with 428 (8.2%) of the 5220 sheep affected and 98 (22.8%) dying. Viruses were isolated by Shanxi Provincial General Veterinary Station and Yunnan Tropical and Subtropical Animal Virus Disease Laboratory (Fig. 3).

#### Isolation of virus from sentinel sheep

From 1987, healthy sheep and goats had been introduced to high prevalence bluetongue areas, such as Xinjiang and the Bayannur region of Inner Mongolia, to establish sentinel stations. These animals were tested regularly in the anticipated bluetongue epidemic season. Viruses were isolated from whole blood from sentinel sheep, the samples having been collected and stored in Inner Mongolia one week before the blood showed AGID-positive. The same results were obtained by NQVI in 1989 from sheep at the Shandong sentinel station and in 1990 from cattle at the Gansu sentinel station.

### Serological Study of Bluetongue Virus

#### General investigation of sheep sera

Serological tests, including AGID, complement fixation, fluorescent antibody, virus neutralisation, enzyme linked immunosorbent assay (ELISA), indirect haemagglutination, haemolysis inhibition and the preparation of monoclonal antibodies (MAB), were modified from published procedures. Antigen for the AGID test was prepared by international procedures. The standard methods of antigen preparation and quarantine were confirmed in China in 1982. A general survey of sera from all over China (Table 5) used the ELISA test, modified by NQVI and YAHVI, and found that:

- the positive rate was higher in the south of China than in the north (i.e. 9.7–35.8% in cattle in the south but 0–0.1% in the north);
- prevalence outside the epidemic area was 0–0.92% in sheep;
- prevalence in goats was higher than in sheep and cattle; and
- infection of suspicious animals all occurred south of 37°N, with none seen further north.

#### Identification of virus serotypes

The serotypes of viruses from sentinel animals in Inner Mongolia, Xinjiang, Hubei, Sichuan and Yunnan were examined by using sheep cross-protection, neutralisation and indirect agglutination tests. The results showed different strains from these areas.

Serotyping of viruses from blood samples from those Provinces and from Yunnan *Culicoides* by micro-neutralisation tests proved that the major serotypes in China were BLU1 and 16 (Table 6). The study of the epidemiology of bluetongue in China is continuing in Yunnan.

Table 5. Random general survey for bluetongue in China.

Years	No. of provinces and regions	Species	No. of animals tested	No. of seropositive animals (%)
1979–1989	7	sheep	40 314	7 406 (18.4)
1987–1989	27	sheep	276 534	13 096 (4.7)
1989	26	cattle	164 575	12 126 (7.3)

Table 6. Times of isolation, identification and distribution of BLU serotype.

Source of virus strain	Year of isolation	Date identified	BLU serotype
Hubei	1984	September 1994	16
Inner-Mongolia	1988	September 1994	related to 17
Sichuan	1988	September 1994	16
Shandong	1989	1990	16
Shanxi, I	1993	September 1994	1
Shanxi, II	1994	September 1994	1
Xinjiang	1989	September 1994, April 1995	1
Yunnan ( <i>Culicoides</i> )	1993	August 1994	1
Yunnan, Y-33	1980	August 1994	1

### Bibliography

- Anon. 1989. Draft procedure for the AGID test for bluetongue. Yunnan Animal Husbandry and Veterinary Journal, 4, 43–44.
- 1989. Draft procedure for the complement fixation test for bluetongue. Yunnan Animal Husbandry and Veterinary Journal, 4, 44–48.
- 1991. Report by the investigative group of the National Quarantine Institute, Preparation and application of BTV antigen for ELISA test. Yunnan Animal Husbandry and Veterinary Journal, 3, 44–47.
- 1991. Report of the investigative group for bluetongue in the National Quarantine Institute. Isolation and identifi-

- cation of bluetongue virus in Gansu Province. *Yunnan Animal Husbandry and Veterinary Journal*, 3, 75-76.
- Bi Yunlong, Li Chundi, Li Shyiing, Qing Bo and Zhong Nan. 1991. Serological survey for bluetongue in Yunnan. *Yunnan Animal Husbandry and Veterinary Journal*, 3, 81-82.
- Chu Guifang, Yi Xunnan, Wu Donglai, Xang Wenhua, Wang Danke, Liu Hong, Chai Hong, Zhang Nianzu, Zi Gen, Li Zhihua, Zhang Khaili, Hu Yuling, Wu Dexing and Yang Yonqin. 1989. Comparison of pathological changes caused by different serotypes of bluetongue in sheep. *Yunnan Animal Husbandry and Veterinary Journal*, 3, 73-74.
- Guo Zaijun, Hao Jucui, Chen Jianguo, Jia Zuoming, Li Zhihua, Zhang Khaili, Hu Yuling, Li Gen and Pu Long. 1989. Survey of bluetongue in the Bayannur region of Inner Mongolia. *Yunnan Animal Husbandry and Veterinary Journal*, 4, 53-56.
- Hu Yuling. 1991. A neutralisation test for bluetongue. *Yunnan Animal Husbandry and Veterinary Journal*, 3, 51-52.
- Hu Yuling, Li Gen, Li Zhihua and Zhang Khaili. 1989. The preparation and application of direct fluorescent antibody in the diagnosis of bluetongue disease. *Yunnan Animal Husbandry and Veterinary Journal*, 4, 20-21.
- Li Gen. 1991. A preliminary study of indirect haemagglutination test for bluetongue. *Yunnan Animal Husbandry and Veterinary Journal*, 3, 51-52.
- Li Gen, Li Gen, Li Zhihua and Zhang Khaili. 1991. Purification of specific antigen of bluetongue and activity test on animals. *Yunnan Animal Husbandry and Veterinary Journal*, 3, 47-48.
- Li Gen and Peng Kegao. 1989. Adaptation of bluetongue virus to BHK cells and the screening of other cells for sensitivity. *Yunnan Animal Husbandry and Veterinary Journal*, 4, 29-30.
- Li Huachun, Zhang Khaili and Li Zhihua. 1991. Survey of Yunnan *Culicoides*, the intermediary vector of bluetongue. *Yunnan Animal Husbandry and Veterinary Journal*, 3, 86-87.
- Li Jinzhang, Chu Guifang, Wu Donglai, Yin Xunnan, Zhang Nianzu, Hu Yuling, Zhang Khaili, Li Zhihua, Li Gen, Zhao Kun and Zhou Fuzhong. 1991. Study of induction mechanism of bluetongue in experimental sheep. *Yunnan Animal Husbandry and Veterinary Journal*, 3, 59-66.
- Lin Lihui, Huang Qiaoling, Kang Changfeng, Zhong Liying, Li Ping, Li Bing and Song Hang. 1989. Isolation of bluetongue virus and a serological survey in Sichuan Province. *Yunnan Animal Husbandry and Veterinary Journal*, 4, 57-60.
- Li Zhihua and Peng Kegao. 1991. Direct isolation of bluetongue virus in cell culture. *Yunnan Animal Husbandry and Veterinary Journal*, 3, 73-74.
- Li Zhihua, Zhang Khaili, Zhou Fuzhong, Hu Yuling, Zhao Kun, Li Gen, Wu Dexing, Peng Kegao and Zhou Yong. 1989. Isolation and identification of the Hubei strain of bluetongue virus. *Yunnan Animal Husbandry and Veterinary Journal*, 4, 49-52.
- Pan Yuzhen and Sun Yuxai. 1991. Serological epidemic survey for bluetongue. *Yunnan Animal Husbandry and Veterinary Journal*, 3, 83-86.
- Qin Qiyang, Tai Zhengguo, Wan Lijin, Luo Zhengqi, Nu Edan, Lin Hanlang and Liu Yifu. 1991. Epidemiological survey of bluetongue and the isolation and identification of bluetongue virus in Xinjiang. *Yunnan Animal Husbandry and Veterinary Journal*, 3, 79-80.
- Sellers, R.F. 1981. Bluetongue and related diseases. In: Gibbs, E.P.J., ed., *Virus diseases of food animals*. Vol. II. Academic Press, 567-584.
- Wu Dexing and Zhang Khaili. 1991. The ELISA test for screening bluetongue monoclonal antibodies. *Yunnan Animal Husbandry and Veterinary Journal*, 3, 57-58.
- Xiao Guiying and Chen Xingfu. 1991. Coagulation and inhibition test of attenuated BLU10. *Yunnan Animal Husbandry and Veterinary Journal*, 3, 55-56.
- Xu Jingqing, Xu Zupeng and Lang Geyu. 1991. Application of modified complement fixation test in survey of bluetongue disease of sheep. *Yunnan Animal Husbandry and Veterinary Journal*, 3, 49-50.
- Zhang Khaili, Wu Dexing, Li Zhihua, Hu Yuling, Li Gen, Peng Kegao and Zhang Nianzu. 1989. A preliminary report of monoclonal antibodies for bluetongue establishment of hybridomas. *Yunnan Animal Husbandry and Veterinary Journal*, 4, 34-36.
- Zhang Nianzu, Hu Yuling, Li Zhihua, Li Gen, Zhang Khaili and Zhou Fuzhong. 1989. The preparation and specific test of soluble antigen for AGID test of bluetongue disease. *Yunnan Animal Husbandry and Veterinary Journal*, 4, 13-16.
- Zhang Nianzu, Li Zhihua, Zhang Khaili, Zhou Fuzhong, Hu Yuling, Li Gen, Xu Wenzhen and Li Chundi. 1989. Tests for bluetongue virus in the organs of artificially inoculated sheep. *Yunnan Animal Husbandry and Veterinary Journal*, 4, 41-42.
- Zhang Nianzu, Zhang Khaili, Li Zhihua, Hu Yuling, Li Gen, Zhao Kun, Zhou Fuzhong and Shanyu Naishun. 1989. Application of agar gel immunodiffusion test for the diagnosis of bluetongue in animals. *Yunnan Animal Husbandry and Veterinary Medicine*, 4, 17-19.
- Zhang Nianzu, Zhang Khaili, Li Zhihua, Shanyu Naishun, Hu Yuling, Li Gen, Zhao Kun, Zhou Fuzhong and Xu Wenzhen. 1989. Investigation and study of bluetongue disease of sheep in Yunnan, China. *Yunnan Animal Husbandry and Veterinary Journal*, 4, 3-12.
- 1989. Tests of the resistance of bluetongue virus to general disinfectants and temperature. *Yunnan Animal Husbandry and Veterinary Journal*, 4, 39-40.
- Zhang Nianzu, Zhang Khaili, Li Zhihua, Zhou Fuzhong, Xu Wenzhen and Li Chundi. 1989. Experimental inoculation of bluetongue virus to cattle and goats. *Yunnan Animal Husbandry and Veterinary Journal*, 4, 32-33.
- Zhou Weihai, Wan Youyin, Cui Xoulong, Liu Sengbao and Su Genyuan. 1991. Distribution and activity of *Culicoides* in Anhui Province. *Yunnan Animal Husbandry and Veterinary Journal*, 3, 84-86.

# An Epidemiological Survey of Bluetongue in Yunnan Province, China

Bi Yunlong, Li Chundi, Li Shiyin, Qing Bo,  
Zhong Nan, Hu Jinfeng and Yang Ruilan\*

## Abstract

A total of 32821 sheep, goats, dairy cows and Chinese Yellow cattle, including five buffalo from Vietnam and 23 Yellow cattle from Myanmar, were surveyed for antibodies to bluetongue virus (BLU) by agar gel immunodiffusion (AGID). This survey gave a clear picture of BLU distribution in 86 counties of Yunnan Province. The 8253 (26.0%) positive animals were distributed in 82 counties, located between 21°30' to 29°N and 97°40' to 106°10'E. Buffalo and Yellow cattle had the highest infection rates (34.1% and 30.6% respectively): these were lower for goats (25.5%), sheep (9.2%) and dairy cows (0.8%). None of the seropositive animals showed clinical signs. The rate of positivity increased from mild climate zones to subtropical and tropical climate zones, and was inversely related to altitude (height above sea level). Disease regulatory authorities were alarmed by the high infection rates found in buffalo and Yellow cattle in the border regions between Yunnan Province and the adjacent countries of Vietnam and Myanmar, as cattle bred in Yunnan Province are often exported to inland provinces of China and could possibly spread bluetongue.

SINCE the discovery in 1979 of bluetongue at and around Shizong County Livestock Farm in Yunnan Province, clinical bluetongue cases have occurred in Wuhan areas, Hubei Province, China. As an emerging disease, bluetongue attracted the attention of relevant authorities because, by infecting sheep and other ruminant animals, and possibly causing high morbidity and mortality, the disease could cause great loss to the local livestock industry.

At that time, the diagnosis of bluetongue relied on clinical observation, virus isolation and bio-assay. It was impossible therefore to define the distribution of epidemic zones and the infection status of other animals in larger areas. By 1982, Yunnan Provincial Institute of Animal Husbandry and Veterinary Science (YPIAHVS) had developed a group-specific soluble agar gel immunodiffusion (AGID) antigen with a Yunnan bluetongue virus (BLU) strain and established diagnostic methods (for which they were awarded second prize for Science and Technology by the Ministry of Agriculture in 1983). Application of

the AGID test for the detection of bluetongue provided a specific diagnostic method.

Following instructions from the Ministry of Agriculture, Animal Husbandry and Fishery and the Provincial Bureau of Animal Husbandry to investigate further the distribution and prevalence of bluetongue in Yunnan Province, we conducted a bluetongue survey in areas with the same or similar ecological conditions to Shizong County where the clinical bluetongue had occurred.

## Materials and Methods

The diagnostic antigen and positive reference serum were developed and provided by YPIAHVS. Test performance and reading parameters were conducted using the 'Draft protocols of agar gel immunodiffusion test for bluetongue in animals' developed by YPIAHVS. Test sera were separated from bloods randomly collected by the relevant Zhou (district) animal husbandry and veterinary stations and stored at 4°C.

Sera were collected from buffalo, cattle, sheep and goats in 49 counties in 13 Zhou. Cattle imported from Vietnam and cattle, swine and horses from Myanmar were also sampled. The sampling rate was 5-10% in the selected herds.

---

\* Yunnan General Station of Animal Husbandry and Veterinary Medicine, Kunming 650051, People's Republic of China.



## Results

### Serological surveys

The geographical distribution and prevalence of bluetongue in Yunnan Province, as determined by our results, can be summarised as follows.

- Of the 19083 ruminant animals tested in 49 counties in 13 prefectures or districts in Yunnan Province, 5918 (31.1%) animals were positive to bluetongue with differences among the species (Table 1). Of the non-Chinese animals tested, all five buffalo from Vietnam were positive (100%), and 13 out of 23 cattle from Myanmar were positive (56.5%).
- Positive animals were detected in all 13 districts (Table 2), and in 48 out of 49 counties (Table 3).

**Table 1.** Prevalence of bluetongue antibodies in various domestic animals in Yunnan Province.

Animals	No. positive/no. tested (%)
Buffalo	1600/3708 (43.1)
Yellow cattle	2644/7307 (36.2)
Sheep	55/990 (5.8)
Goats	1616/6175 (26.1)
Dairy cattle	9/850 (1.1)
Horses	0/13
Pigs	0/40
Total	5918/19083 (31.1)

**Table 2.** Detection of bluetongue in various districts or regions of Yunnan Province.

District or region	No. positive/no. tested (%)
Lincang District	343/630 (54.6)
Dehong Zhou	615/1292 (47.6)
Simao District	313/719 (43.5)
Honghe Zhou	990/2332 (42.5)
Yuxi District	1346/3273 (41.1)
Xishuang Banna Zhou	28/73 (38.4)
Chuxiong Zhou	161/500 (36.2)
Wenshan Zhou	1391/4078 (34.1)
Zhaotong District	99/363 (27.3)
Lijiang District	53/231 (22.9)
Dali Zhou	116/761 (15.2)
Qujing District	372/3069 (12.1)
Kunming Municipality	66/1757 (3.8)

### Geodistribution and epidemiological features

Forty-eight counties had a positive infection rate greater than 50%; 17 counties rates greater than 30%; 12 counties rates greater than 10%, and 7 counties rates less than 10%. Ruili County had the highest positive rate (79.4%) while Songming and Fuyuan Counties had the lowest positive rates (0.9%). The positive areas involving 48 counties were located between longitude 97°40' and 106°10'E and latitude 21°30' and 29°N. The high incidence and wide distribution in many new areas attracted much attention.

Testing of sera of ruminants without clinical signs was done with a group-specific AGID antigen. The infection was limited to ruminants: sera from a few non-ruminant animals were negative to bluetongue. Among ruminants, the highest infection rates were found in buffalo and cattle but no significant clinical signs were seen. Sheep and dairy cattle with low infection rates were also found to be free of clinical cases. The rank order by prevalence in ruminants was buffalo 43.7%, Yellow cattle 36.2%, goats 25.9%, sheep 5.8% and dairy cattle 1.1%. Many of the tested cattle and buffalo also had antibodies to epizootic hemorrhagic disease (EHD) viruses: the reason for the high level of association is unknown.

The distribution of bluetongue infection varied in relation to altitude and climate (Table 4). Positive rates of infection seemed inversely related to the altitudes above sea level ie. low altitude > medium altitude > high altitude, with rates in tropical zones being greater than in subtropical zones, which were in turn greater than in temperate zones. These results suggest that natural ecological conditions vary with altitudes and climate zones, causing different distribution and density of the *Culicoides* insect vectors.

### Geographical distribution

The positive rates of infection in border areas were higher than those in inner areas. For example, the prevalence was from 43.1% to 54.5% in the six border districts or prefectures (Lincang, Dehong, Simao, Xishuang Banna, Wenshan and Honghe) and 3.8% to 41.1% in the seven inner districts or regions (Kunming, Dali, Chuxiong, Lijiang, Qujing, Yuxi and Zhaotong), indicating an association with tropical and subtropical climates of the border areas. It seemed the epidemic had been long established and there was a trend for the disease to spread from border areas to inner regions. It was thus possible that the border areas and beyond were the source of the infection.

**Table 3.** A serological survey of bluetongue by species and district distribution: Yunnan Province, Vietnam and Myanmar.

District or Zhou	County	Total no. animals tested		Buffalo		Yellow cattle		Dairy cattle		Goats		Sheep		Pigs or horses	
		positive/ tested	%	positive/ tested	%	positive/ tested	%	positive/ tested	%	positive/ tested	%	positive/ tested	%	positive/ tested	%
Lincang	Shuangjiang	165/290	56.9	149/262	56.8	16/28	57.1								
	Genma	133/242	54.9	17/38	44.7	116/204	56.7								
	Cangyuan	42/92	45.6			2/7	28.5			40/85	47.0				
	Zhenkang	3/6	50.0			3/6	50.0								
Dehong	Luxi	337/639	52.7	84/137	61.3	29/63	46.0			219/334	55.0	5/105	4.7		
	Ruili	81/102	79.4	40/50	82.0	40/52	76.9								
	Lianghe	59/174	33.9	5/74	6.3					54/100	54.0				
	Yanjiang	41/102	40.2	2/3	66.6					39/99	39.4				
Simao	Longchuan	84/252	33.3	12/83	14.5	12/50	24			31/46	67.4	29/73	39.7		
	Zhenyuan	66/182	36.3	43/86	50.0	19/56	33.9			4/40	10.0				
	Simao	98/203	48.2			98/203	48.2								
	Manglian	106/206	51.5	79/164	48.2	27/42	63.3								
Banna	Mojiang	43/128	33.6	18/43	41.8	4/23	17.4			21/62	33.8				
	Jinghong	28/73	38.4	9/18	50.0	19/48	39.6			0/7					
Chuxiong	Yuanmao	159/235	67.6	99/178	76.1	32/50	64.0			28/29	95.5	0/26			
	Shuangbo	22/265	8.5	3/78	3.8	9/88	10.2				4.1				
Wenshan	Masupo	252/492	51.2	516/394	54.8	36/98	36.7								
	Xishou	232/517	44.9	69/138	50.0	154/359	42.2			9/20	45.0				
	Funing	233/554	42.1	121/270	44.8	112/284	39.4								
	Yanshan	159/500	31.8	40/125	32.0	48/199	24.1			71/176	40.3				
	Wenshan	200/733	27.2	102/269	37.9	70/246	28.4			28/218	12.8				
	Guangnan	177/478	37.0	51/142	35.9	126/336	37.5								
	Maguang	105/599	17.5	34/137	24.8	55/408	13.5			16/54	29.6				
	Quibei	33/205	16.1			8/98	8.1			25/107	23.3				
Yuxi	Yuanjiang	839/1548	54.2	80/159	50.3	503/1036	48.6			256/353	72.5				
	Eshan	184/425	43.2	153/202	75.7	7/19	36.8			24/199	12.1			0/5	0
	Yimen	192/2644	14.2			0/3				92/641	14.3				
	Xinping	231/3656	35.2	41/101	40.6	2/4	50.0			188/511	34.1				
Dali	Weishan	49/264	18.6			49/213	23.0			0/51					
	Wiangyun	29/272	10.7			25/173	14.5			4/99	4.0				

**Table 3.** A serological survey of bluetongue by species and district distribution: Yunnan Province, Vietnam and Myanmar.

District or Zhou	County	Total no. animals tested		Buffalo		Yellow cattle		Dairy cattle		Goats		Sheep		Pigs or horses	
		positive/ tested	%	positive/ tested	%	positive/ tested	%	positive/ tested	%	positive/ tested	%	positive/ tested	%	positive/ tested	%
Honghe	Nanjian	38/205	18.5	25/51	49.0	8/51	15.7			5/50	10.0	0/53			
	Yangbi	0/20				0/10				0/10					
	Jinping	249/548	45.3			240/522	45.9			9/26	34.6				
	Henkou	74/120	61.7			74/120	61.7								
	Honghe	259/483	53.6	23/42	54.7	198/387	51.2			38/54	70.3				
	Luchun	63/177	35.6			37/105	35.2			26/72	36.1				
	Yuanyang	319/901	35.4			269/685	39.3			50/216	23.1				
Jiashui	26/103	25.2			6/25	24.0			20/30	66.6				0/*40 0/†8	
Qujing	Huize	54/966	5.6			3/11	27.3			48/382	8.2	3/372	0.8		
	Luoping	184/366	50.3			59/94	62.7			125/272	45.9				
	Luliang	103/431	23.8	28/99	28.3					68/294	30.4	7/108	6.4		
	Qujing	10/263	3.8			5/143	3.5	4/70	5.7	1/50	2.0				
	Xundian	17/613	2.8			11/307	3.6			6/306	1.9				
Fuyuan	4/430	0.9			4/189	2.1			0/241						
Zhaotong	Qiasjia	99/363	27.3	29/93	31.3	57/90	63.3			13/130	10.0				
Lijiang	Yongsheng	53/231	22.9	8/44	18.2	13/32	40.6			22/80	27.5	10/75	13.3		
Kunming	Lunan	51/306	16.6	11/73	15.1	26/109	23.8			13/63	20.1	1/61	1.6		
	Yilian	7/330	2.1	0/16		0/8				7/306	2.3				
	Songming	3/341	0.9	3/182	1.6					0/93		0/66			
	Livestock Breeding Farm	0/409							0/409						
	Xiaoshao Farm	5/140	3.5						5/140	3.5					
	No. 2 Farm	0/31							0/31						
Vietnam		5/5	100	5/5	100										
Myanmar		13/23	56.5			13/23	56.5								
	<b>TOTAL</b>	5918/19083	31.0	1600/3708	43.1	2604/7307	36.2	9/80	1.1	1610/6175	26.1	55/990	4.8	0/*40 0/†13	

\*Pigs, †horses

**Table 4.** Altitude above sea level and climatic zone in relation to prevalence of bluetongue antibodies.

Items	Altitude (metres above sea level)			Climatic Zones		
	Below 1000 m (Low)	Above 1000 m (Medium)	Above 1800 m (High)	Above 20°C	Above 15°C	Above 10°C
No. counties tested	11	28	9	7	33	8
No. of animals tested	4444	9980	4578	2921	11777	4304
No. of positives	2181	3439	280	1539	4110	251
% of positives	49.2	34.5	6.1	52.7	34.9	5.8
% Range	27.3–79.4	2.1–67.6	0.9–22.9	27.3–79.4	2.1–56.9	0.9–22.9

## Discussion

Yunnan Province borders Myanmar, Vietnam and Laos, and has some natural ecological conditions in common with these border countries. The survey showed that Yellow cattle from Myanmar yielded a positive rate of 56.6% and all five buffalo from Vietnam were positive. In border areas, trade fairs are frequent and busy. Yellow cattle and buffalo from adjacent countries are often on sale in the markets of the border counties in Yunnan Province. Border crossing or mixed pasturing is a common practice. In addition, as BLU is transmitted by blood-sucking insects, buffalo and Yellow cattle were heavily infected through insect bites and infestation. For example, in Ruili county which borders Myanmar, the positive rate was 79.4%; in Luxi County 52.7%; in Yanjiang County 40.2%; in Minlian County 51.5%; in Genma County 54.9%, in Jinghong County 38.4%; in Hekou County 61.7%; in Jingping County 45.3%; and in Mapo County 51.2%. These counties border Vietnam. The border counties are the main breeding areas for buffalo and Yellow cattle, and their frequent movement inland was a main cause of bluetongue spreading to inner counties in the Province. The results of the survey suggest that bluetongue was introduced into Yunnan Province from the neighbouring countries long ago.

The geographical and climatic conditions are very complex. Due to a great variation in altitude in Yunnan Province, tropical, subtropical and temperate climates exist in the same region or county, particularly in border areas, resulting in higher annual mean temperatures. Among 49 counties investigated, 40 counties have an annual mean temperature greater than 15°C and relative humidity greater than 70%. This suits the activity and survival of blood-sucking insects. There are 34 species of blood-sucking *Culicoides* in this Province: the main BLU vectors, *C. schultzei*, *C. gemellus*, *C. peregrinus*, *C. arakawae* and *C. circumscriptus*, exist in most parts of the

Province. Hence, bluetongue has probably existed for a long time with a wide distribution in Yunnan Province.

Because the infected cattle do not show significant clinical signs, people are often unaware of the infection and the animals may carry virus for a long time. According to published accounts from the USA, viraemia may persist for more than one year in cattle after infection with bluetongue. Some experiments showed that bluetongue virus was isolated five years later from erythrocytes of inapparently infected cattle. The viraemia in sheep lasts more than three months, during which time the animals are infectious. Therefore, cattle carrying bluetongue virus would be the main source of infection for bluetongue in Yunnan Province. Furthermore, this survey found no clinical signs in the infected sheep, even though the infection rate in cattle was very high in the same area. Whether the antibodies were produced by cross infection with other related viruses has not been confirmed. Further study and classification of the virus serotypes remained to be done.

In summary, Yunnan Province has the conditions necessary for bluetongue disease to occur and spread: vectors (blood-sucking *Culicoides*); virus-carrying cattle without clinical signs; susceptible animals such as sheep, goats and cattle; and the appropriate natural ecological environment. Since the disease was introduced, it has persisted, spread and been transmitted, with the border region of Yunnan Province as the natural focus area. The 1979 outbreak of bluetongue in sheep in Shizong County can be assumed to have been an example of the disease spreading from border areas to the inner parts of the Province. The survey further indicated that Shizong County was not a single isolated focus of bluetongue infection, but merely the first place where clinical signs were found.

Bluetongue in Yunnan Province has a wide distribution and high morbidity. Any proper and active control measures should take account of the natural and economic conditions of the Province. It is not

recommended that the positively reacting animals be massively slaughtered: rather they should be fed and used as draught animals in locally confined areas and prohibited for use as breeders. In North America and Australia, movement of positive animals has been restricted and this precedent may be followed in China.

The serological survey also revealed that 13/23 Yellow cattle from Myanmar and 5/5 buffalo from Vietnam were positive. There were no reports of bluetongue in these two countries before 1985,

according to the FAO Veterinary Year Book. Since this study is the first time that bluetongue antibodies were detected in animals from these two countries, this provides some information for bluetongue research and control there.

The diversity of BLU serotypes complicates control of the disease. To prevent new introductions into the Province, based on the identity of BLU serotypes and their distribution in Yunnan Province, animal quarantine should be strengthened and all seropositive animals prohibited from entry.

# Epidemiological Investigations and Control of Bluetongue Disease in Jiangsu Province, China

Zhu Changgui\*, Li Yamin\*, Shao Cuili\*, Xu Shibai† and Zheng Tianran§

## Abstract

In 1986 the first bluetongue infections were detected in dairy cows imported from Denmark, using agar gel immunodiffusion (AGID) and ELISA serological tests. In 1988 an epidemiological investigation was carried out throughout Jiangsu Province. Bluetongue antibodies were found in 60/3853 (1.5%) cattle sera and in 63/2426 (2.2%) sheep and goat sera. Serological and clinical observations showed the existence of bluetongue infection in some areas of Jiangsu Province. All seropositive animals were slaughtered, and quarantine and vaccination programs were enforced. The disease was effectively controlled in the Province.

In 1986, among 32 cows imported from Denmark to Lianyungan City, Jiangsu Province, four animals tested positive for bluetongue antibodies by agar gel immunodiffusion test (AGID) and enzyme linked immunosorbent assay (ELISA) serological tests. Until then, bluetongue positives had never been reported. This result caused special attention to be directed towards the control of bluetongue.

In 1988, a bluetongue epidemiological survey and eradication program were initiated. Some cows, goats and sheep were seropositive although no clinical signs were observed. Most of the seropositive animals were slaughtered but some were kept in isolation without clinical signs being observed.

In the flood season of 1991, clinical bluetongue occurred in Tongshang County, Jiangsu Province, with sera positive by AGID. An epidemiological investigation began soon after the disease outbreak. All animals that were seropositive or had clinical signs of bluetongue were slaughtered. From spring 1994, a vaccination program was enforced for cattle, sheep and goats in the infected area. Bluetongue has

been effectively controlled. This paper reports the results of the epidemiological investigations and the vaccination and eradication programs.

## Animal Investigations

In Jiangsu Province 76 cattle and 14 sheep or goats in herds or flocks were studied. Some individual animals were also tested. Full clinical examinations were carried out and blood samples collected from all males and 20% of females, breeders and other animals. In total, 3798 dairy cattle, 511 goats and sheep were tested, as well as 229 individually owned buffalo. The AGID test was carried out using the standard protocols and reagents of the Ministry of Agriculture.

No clinical signs of bluetongue were observed. Four dairy farms and one sheep farm proved positive, while a further two dairy farms and one sheep farm were suspect. Forty-two cows and one sheep, plus 55 individual buffalo, tested positive (Table 1).

## Epidemiology During Outbreak in Tongshang County

In August 1991, bluetongue broke out in sheep flocks near a border in Tongshang County, Jiangsu Province. The sheep had persistent high fever (41–42°C), swollen faces and muzzles, buccal erosions, excess

\* Animal Husbandry and Veterinary Station of Jiangsu Province, Nanjing, 210024, People's Republic of China.

† Animal Husbandry and Veterinary Station of Xuzhou, People's Republic of China.

§ Animal Hospital of Tongshang County, People's Republic of China.

salivation and swollen blue tongues. Lameness and paralysis were observed in some sheep. The clinical course lasted 7 to 14 days. Of the more than 100 clinically ill sheep, 30 died. All remaining clinical cases were slaughtered.

Two serum samples collected two and four days after recovery tested negative by AGID, although three samples collected 15 days after recovery tested AGID positive at the Qingdao Institute for Animal Inspection. After the laboratory confirmation, serum samples from 12 valleys and farms showed 14/34 sheep, 4/58 goats and 4/13 Chinese Yellow cattle were AGID positive.

### Prevention and Control

As bluetongue had never before been reported in Jiangsu Province, a restriction and control policy was enforced to prevent further spread of the disease. Four seropositive cows in an imported dairy herd, and all animals demonstrated or suspected as being seropositive in the AGID test, were slaughtered. Some seropositive buffalo in Yizhen and seropositive cows in the Zaicheng dairy farm in Lishui County were kept under isolation, rather than being slaughtered, as there were too many seropositives. This slaughter out policy for seropositive sheep in Tongshang County continued in 1993 and 1994. However, because of the difficulty of slaughtering all seropositives in such a large area, a vaccination program was introduced in the risk area after spring 1994. Cows, sheep and goats were inoculated with the vaccines, which contained two serotypes of attenuated bluetongue virus produced by the Yunnan Animal Husbandry and Veterinary Medicine Institute. From 63% to 93% of animals in the infected area were vaccinated.

### Effects of Preventative Measures

The combination of slaughter or isolation of seropositive animals and vaccination of the remainder reduced morbidity remarkably. On some farms, no seropositive animals have been detected since the original seropositive animals were slaughtered in 1988. However, the seropositive prevalence has remained high where positive animals were detected in 1988 and not slaughtered.

To examine the effects of prevention and control, serological investigations were again conducted, in March 1993, in some of the areas where positive animals were detected in the earlier epidemiological surveys. If the original farm with seropositives had closed down, blood samples were collected from surrounding areas or farms (Table 2).

The slaughter of seropositive animals, especially when these comprised whole flocks, removed the threat of bluetongue infection from flocks and farms (Table 2). In the Zaicheng dairy farm, where the seropositive cows were not slaughtered but raised in isolation after 1988, the seropositive rate remained high. In the buffalo in Yizhen, where the 1988 seropositives were again not slaughtered, the positive rate in the recent investigation was high, at 46%. In Tongshang County, four sheep showed clinical signs in 1992 but were not slaughtered and no other measures were taken. The morbidity and mortality increased dramatically in 1993 when 34 sheep had bluetongue signs.

In Tongshang County, the slaughter and vaccination programs have meant that bluetongue morbidity has decreased year by year since the 1991 outbreak (Table 3). In 1994, only one sheep, which had missed vaccination, demonstrated bluetongue signs.

**Table 1.** Bluetongue positive farms and animals detected by AGID during 1988 study in Jiangsu Province.

Farms and areas	Species	No.	Results			
			Positive		Suspected	
			No.	%	No.	%
Zaichen dairy farm, Lishui County	Dairy cow	64	38	59		
Dairy breeder farm, Heian County	Dairy cow	20	2	10		
Dairy farm, Rudong County	Dairy cow	61	1	2		
Dairy farm, Nantong County	Dairy cow	23	1	4		
Dairy farm, Dantu County	Sheep	10	1	10		
Fumazhuan dairy farm, Zhengjiang	Dairy cow	50			1	2
Huangtang dairy farm, Zhengjiang	Dairy cow	31			1	3
Xinkun sheep farm, Qidong County	Sheep	30			5	17
Yizhen City	Buffalo	119	55	46		

**Table 2.** Comparisons of AGID positive rates in infected farms or areas before and after preventative and control measures.

Location	Species	Results from recent surveys			% positive in 1988	Remarks
		No. tested	No. positive	%		
Zaichen dairy farm Lishui County	Dairy cow	20	5	25	59	Original cows on farm all slaughtered
Heian County	Cows, sheep	23	0	0	10	Original cows on farm all slaughtered
Gongxiao breeder farm, Rudong County	Dairy cow	12	0	0	1.6	Original farm closed
Dairy farm, Nantong County	Dairy cow	12	0	0	0	
Rongbin District, Dantu County	Sheep	9	1	11	10	Original farm closed, samples collected from animals nearby
Fumazhuan dairy cow farm, Zhenjiang	Dairy cow	22	0	0	Suspected	
Huanghai sheep farm, Qidong	Sheep	10	0	0	Suspected	Original farm closed
Dongxin dairy farm, Liangyugan	Dairy cow	18	0	0		
Yizhen County	Buffalo	16	6	37	46	Samples came from 119 animals tested in 1988

**Table 3.** Morbidity and serological investigation of bluetongue in Tongshang County after preventative measures.

Year	Diseased		AGID test results			Remarks
	Species	No.	Species	No. tested	No. of positives	
1991	Sheep	>100	Sheep, goats, cows	305	22	All diseased and seropositive animals slaughtered
1992	Sheep	4				Not slaughtered
1993			Cows	64	5	Positives slaughtered, remainder vaccinated.
1994 (March)			Cows	64	5	Positives slaughtered, remainder vaccinated.
1994 (Dec)	Sheep	1	Sheep	56	1	Diseased and seropositive sheep, 16 of 56 vaccinated

## Discussion and Conclusion

The epidemiological investigations in Jiangsu Province, especially in Tongshang County, clarified the regional bluetongue situation. Before 1991, only seropositive animals were known and no clinical cases were reported. The first outbreak in Jiangsu Province was restricted to a small area of Tongshang County and did not spread through the Province

because of the combined preventative measures of slaughter and vaccination. Clinical bluetongue was found mainly in sheep, with rare exceptions of cases in goats and cows.

All the above results emphasised the importance of slaughtering clinically ill and seropositive animals to prevent and control the spread of bluetongue. Slaughter of seropositives, especially where they comprised 10% or more of the animals, freed farms of blue-



tongue. Where no slaughter occurred (on the Zaicheng dairy farm and with the Yizhen buffalo), the infection rate remained high (Table 2)

The vaccination program was very effective (Table 3) as the vaccine had a high efficacy. No clinical cases occurred in 3264 vaccinated sheep. Blood sam-

ples from 40 of the vaccinated sheep were negative in AGID testing, showing that the vaccine did not induce AGID antibody. However, some unvaccinated animals were positive in AGID testing, which indicated that the vaccine could prevent infection with virus.

# An Epidemiological Study of Bluetongue in Anhui Province, China

Zhou Weihan\*

## Abstract

Between 1987 and 1991, bluetongue was reported by three counties in Anhui Province, and was recognised by the isolation of bluetongue virus (BLU). Sheep morbidity was 33% and mortality 11.3%. A serological survey of domestic ruminants showed that the seropositive rate in the epidemic region was higher than in a non-epidemic region. Local cattle, buffalo and sheep had higher positive rates than goats and dairy cattle. Merino sheep were more likely to be seropositive than Corriedale and Romney sheep, as were grazing herds compared to sheltered feeding herds, but there was no age-related difference in prevalence. Twelve species of *Culicoides* midges are found in Anhui. The dominant mammal-feeding midges are *C. oxystoma*, *C. homotomus* and *C. nipponensis*, with *C. homotomus* as a potential BLU vector in this region. Local cattle and buffalo may be the overwintering hosts for BLU.

AN outbreak of bluetongue occurred in Chuzhou City in Anhui Province. The isolation and identification of bluetongue virus (BLU) by the Animal Quarantine Institute, Qingdao, confirmed the diagnosis. From then on, comprehensive investigations and observations were conducted on the epidemiology of bluetongue. This paper reports the preliminary results.

## The Occurrence of Bluetongue

Between 1986 and 1992, outbreaks of bluetongue occurred in two locations in Anhui Province, at about 32°30'N, 118°E; one at a sheep breeding farm in Lanya District, Chuzhou City, the other in the border area between Xiaoxian and Suixi counties (Table 1). Intensive sheep production occurs at both locations.

## Serological Investigation

Between 1986 and 1992, 15 383 domesticated ruminants, in 40 counties and cities of Anhui Province, were tested for BLU antibodies by agar gel immun-

odiffusion (AGID), using antigens provided by the Yunnan Provincial Institute of Animal Husbandry and Veterinary Science and the Animal Quarantine Institute, Qingdao. The average rate of seropositives was 21.8% (range from 0–75%), with no positive results detected in 602 animals in eight counties and cities. Statistical analysis showed the prevalence rates among Yellow cattle, buffalo and sheep were not significantly different ( $P>0.05$ ), although rates among these three were significantly greater ( $P<0.01$ ) than in goats and dairy cattle (Table 2).

The overall prevalence was significantly greater in epidemic areas than in non-epidemic areas (Table 3); the prevalences in Yellow cattle, sheep and goats in epidemic areas were significantly higher than in the corresponding domestic species in non-epidemic areas (too few buffalo and dairy cattle were studied for adequate comparisons). In epidemic areas, the seropositive rate among sheep was greater than among Yellow cattle, which in turn was greater than among goats ( $P<0.01$ ). In non-epidemic areas, positive rates among Yellow cattle and buffalo were greater than among sheep, which were greater than among goats, which in turn were greater than among dairy cattle ( $P<0.01$ ). The positive rate was higher in sheep than in Yellow cattle in the epidemic areas, while in the non-epidemic areas the positive rate among Yellow cattle and buffalo was higher than that among sheep.

---

\* Veterinary Service, Agricultural Department of Anhui Province, No 3 Huizhou Road, Hefei 230001, People's Republic of China.

**Table 1.** Annual prevalence of bluetongue in Anhui Province, China, 1986–1991.

Year	Months	Foci	No. of animals	No. of sick animals (%)	No. of deaths (%)
1986*	July–August	2 holdings (Chuzhou)	236	130 (55.1)	34(26.2)
1987	June–August	5 holdings (Chuzhou)	914	507 (55.5)	49 (9.7)
1989	August	5 holdings (Chuzhou)	378	160 (42.3)	8 (5.0)
1989	August–October	6 townships (Xiaoxian)	3530	810 (22.9)	37 (4.6)
1991	September–October	9 townships (Xiaoxian)	12 358	2794 (22.6)	946 (33.9)
1991	August–October	Maqiao, Suixi	17 000	6635 (39.0)	179 (2.7)
Total			34 416	11 036 (32.1)	1250 (11.3)

\*The annual prevalence in 1986 was derived retrospectively.

**Table 2.** Prevalence of bluetongue antibodies in livestock in Anhui Province.

Species	No. positive/no. tested (%)
Yellow cattle	1231/4554 (27.0)
Sheep	1209/4724 (25.6)
Buffalo	361/1464 (24.7)
Goats	514/3811 (13.5)
Dairy cattle	37/805 (4.6)
Total	3352/15 358 (21.8)

Within a single test unit, tests done at the same time showed positive rates among Merino sheep to be greater ( $P < 0.01$ ) than among Corriedales, which in turn was greater ( $P < 0.01$ ) than among Romneys (Table 4).

A comparison was made between different feeding patterns among goats and sheep in epidemic areas in Xiaoxian County: the positive rates among grazing herds were higher than those among sheltered feeding herds (Table 5). (Cattle have the same feeding patterns so no comparisons were appropriate.) The relationship between age and prevalence was also investigated, in Yellow cattle and sheep of different ages in Fengtai County, a non-epidemic area (Table 6). Positive rates among animals of different ages were not significantly different ( $P > 0.05$ ).

**Table 3.** Seropositive rates in epidemic and non-epidemic areas in Anhui Province.

	Yellow cattle (no. positive/ no. tested)	Buffalo (no. positive/ no. tested)	Sheep (no. positive/ no. tested)	Goats (no. positive/ no. tested)	Dairy cattle (no. positive/ no. tested)	Total (no. positive/no. tested)
Epidemic	716/2446	3/12	814/2862	382/2029	1/1	2016/7350 (27.4%)
Non-epidemic	515/2108	358/1452	295/1862	132/1862	36/804	1336/8008 (16.7%)

### Investigation of *Culicoides* Species as Possible Bluetongue Vectors

*Culicoides* midges were captured by nets and light traps from different animal houses and their surroundings, and also by suction from the skin of bait animals. In this way 22 096 *Culicoides*, identified to 12 distinct species (Table 7), were caught in 33 counties and cities. *Culicoides oxystoma*, *C. homotomus*, *C. nipponensis* and *C. arakawae* were the dominant species in the Province, with *C. mihensis* and *C. actoni* less prevalent.

Electrophoresis of *Culicoides* meals was used to demonstrate that *C. oxystoma*, *C. homotomus*, *C. nipponensis*, *C. mihensis* and *C. actoni* feed on the blood of various animals (buffalo, Yellow cattle, dairy cattle, donkeys, goats, sheep and pigs) while *C. arakawae* feeds on the blood of chickens.

#### Analysis of *Culicoides* species as possible bluetongue vectors

*Culicoides actoni* was captured in 10 counties in Anhui Province, three of which (Chuzhou, Xiaoxian and Suixi) were in the bluetongue epidemic areas. *Culicoides actoni* has been confirmed as being able to transmit BLU in China. However, because of the small number of *C. actoni* captured, representing only 0.2% (17/7732) of the total captured in Chuzhou, 0.8% (14/1818) in Xiaoxian and 1% (2/194) in Suixi, the seasonal occurrence of the species could not be determined. Further work remains to be done.

**Table 4.** Prevalence of bluetongue antibodies in different breeds of sheep.

Breed of sheep	No. positive/no. tested (%)
Merino	14/82 (17.1)
Corriedale	4/138 (2.9)
Romney	0/82 (0)

**Table 5.** Prevalence of bluetongue antibodies in sheep with different feeding patterns.

Feeding pattern	Goats	Sheep
	(no. positive/ no. tested)	(no. positive/ no. tested)
Sheltered feeding	41/720	173/1127
Grazing	120/400	540/1073
Significance	P< 0.01	P< 0.01

*Culicoides homotomus* is the dominant species feeding on domestic mammals in Anhui Province. It is also the dominant species in the two epidemic counties, comprising 31.3% (2418/7732) of the total captured in Chuzhou and 23.9% (434/1818) in Xiaoxian county. In Suixi County the number of *C.*

*homotomus* comprised 54.1% of the total captured, which was greater than the number of *C. oxystoma*.

Bluetongue outbreaks were associated with the activity peaks of *C. homotomus*. In Chuzhou, the peak activity period of *C. homotomus* falls between 15 May and 13 July. Bluetongue prevalence among sheep occurred from June to August. In Xiaoxian, peaks in *C. homotomus* populations occur between 10 July and 25 August, and bluetongue occurred in sheep from August to October. Taking intrinsic and extrinsic incubation periods into account, the activity peak of *C. homotomus* was considered to be associated seasonally with bluetongue.

*Culicoides homotomus* is found exclusively in China and Japan, so its vector function may not have been studied in other countries. As both *C. homotomus* and *C. variipennis* (a *Culicoides* BLU vector in USA) are in the same subgenus, *C. homotomus* is a possible suspect as a BLU vector in Anhui Province. In Chuzhou County, *C. nipponensis* comprised 18.1% (1401/7732) of the total captured, although only 6.2% (12/19) in Suixi and 0.8% (15/1818) in Xiaoxian. The difference in the numbers captured in the two epidemic areas was highly significant (P<0.01). In the counties in Anhui Province north of the Huaihe River, *C. nipponensis* was captured in significant numbers. However, the possibility of *C. nipponensis* being a bluetongue vector is quite low.

**Table 6.** Prevalence of bluetongue antibodies in animals of different ages (no. positive/no. tested).

Age in years	1	2	3	4	5	6	7	8	9	10	Total
Yellow cattle	8/38	19/22	15/48	28/58	14/34	6/23	1/20	2/4	1/1	0/1	98/298 (32.8%)
Sheep	1/12	0/8	0/4	1/2	1/5	-	-	-	-	-	3/31 (9.7%)

**Table 7.** *Culicoides* species identified in 33 counties and cities of Anhui Province.

<i>Culicoides</i> species	No. captured	% of total	No. of counties in which collected
<i>C. oxystoma</i>	10 719	48.5	32
<i>C. homotomus</i>	6587	29.8	30
<i>C. nipponensis</i>	3153	14.3	26
<i>C. arakawae</i>	1423	6.4	25
<i>C. mihensis</i>	120	0.5	7
<i>C. actoni</i>	77	0.3	10
<i>C. maculatus</i>	5	0	2
<i>C. sigaensis</i>	4	0	3
<i>C. pulcaris</i>	3	0	3
m (unidentified)	3	0	1
<i>C. matsuzawai</i>	1	0	1
b (unidentified)	1	0	1
12 species identified	22 096	100	33 counties investigated

*Culicoides oxystoma*, the largest population overall, comprised 48.2% (3727/7732) of the total number of *Culicoides* captured in Chuzhou, 66.1% (1202/1818) of those in Xiaoxian, and 28.4% (55/194) of those in Xuixi. However, as there was no apparent association of its seasonality with bluetongue, more data would be needed to consider *C. oxystoma* as a BLU vector.

The other *Culicoides* species are less suspect as BLU vectors, either because they do not feed on mammals, because their distribution is unrelated to the epidemic counties, or because they are less prevalent overall.

## Discussion and Conclusion

In 1987, an outbreak of bluetongue occurred in Chuzhou city, Anhui Province and was confirmed by virus isolation. Since then, bluetongue has been reported in three counties, affecting 11 036 sheep with a morbidity of 32.1% and mortality of 11.3%. Other livestock in the epidemic areas were not affected. Bluetongue disease occurred mostly between June and October, with the peak from July to September. In addition to *Culicoides* activity and feeding habits, farming practices must be considered. Farmers have recently begun to postpone shearing by more than a month to encourage greater wool production. Shearing takes place in mid-June in Chuzhou city and in the first ten days of July in Xiaoxian County. As bare sheep are more susceptible to *Culicoides* attack, this practice was probably one of the factors accounting for the seasonal dynamics of the disease.

Serological examination by AGID antigen was conducted on 15 358 ruminants, with 21.8% (3352) testing positive. In descending order of prevalence, seropositives were found among Yellow cattle, buffalo and sheep; goats; and dairy cattle. Prevalence in epidemic areas was greater than in non-epidemic areas. Among sheep, prevalence was greatest in Merinos, followed by Corriedales, followed by Romneys, and greater in grazing flocks than in sheltered flocks. Prevalence in Yellow Cattle and goats showed no significant difference by age or sex.

*Culicoides actoni* and *C. homotomus* were considered the most likely BLU vectors in Anhui Province. It is therefore recommended that their seasonal occurrence and their relationship with disease prevalence be investigated. There is a need to prepare BLU fluorescent antibody so as to be able to examine the insects for their ability to carry virus. It is important to isolate BLU from *Culicoides* as a first step to ascertaining which species are vectors.

As bluetongue is an arthropod-borne disease, there is a practical question to be answered to aid in research and control, namely, where does the virus overwinter when there is no *Culicoides* activity?

These surveys revealed that buffalo and Yellow cattle had the highest seropositive rates and that there were no significant differences in these rates among buffalo, Yellow cattle and sheep in epidemic areas. However, in non-epidemic areas positive rates among buffalo and Yellow cattle were significantly higher than among sheep. Data show that viraemia in sheep lasts 63 days, far less than the 107 days of the non-*Culicoides* activity period in Anhui Province, while viraemia in Yellow cattle may last as long as 42 months. One can thus assume, provisionally, that buffalo and Yellow cattle are the overwintering hosts of BLU in Anhui Province, although the possibility of vertical transmission in *Culicoides* does exist. An attempt is being made to rear *Culicoides* experimentally to study the overwintering dynamics, and to establish an experimental colony of *Culicoides* to elaborate the mechanisms of this aspect.

At the beginning of the investigation, the source of infection was suspected of being linked to the importation into a sheep farm of breeding sheep from other countries. Efforts were directed towards determining whether this notion was correct. As the investigations continued, relatively high prevalences of bluetongue antibodies were detected not only in counties which had no relationships with the farms that had imported sheep but also in areas where no sheep had ever been raised. For example, in Jingde County, which is 200 km away from the farm which imported sheep, the prevalence among Yellow cattle was 75% (15/20). Anecdotally, the author treated a sick sheep in 1955 which, in retrospect, could have been a case of bluetongue. From the investigation of *Culicoides* in the whole Province and other evidence, bluetongue appears to have existed in Anhui Province for many years. There is certainly insufficient evidence to support the hypothesis that bluetongue was introduced to Anhui from outside China.

## Acknowledgments

Professor Lu Yixin, Military Medical Academy provided instructions on *Culicoides* work. Dr Zhang Zichun and Dr Zhang Zhijun of the Animal Quarantine Institute, Ministry of Agriculture, isolated and identified the virus. Dr Su Genyuan, Anhui Provincial Institute of Animal Husbandry and Veterinary Medicine, collected and reared *Culicoides*. The Provincial Animal Husbandry Bureau and County Veterinary Stations gave assistance in bluetongue and *Culicoides* investigations.

## Bibliography

Reports available in Anhui Animal Husbandry and Veterinary Medicine Journal, vols. 1, 2 and 3.

# Epidemiological Investigations and Isolation of Bluetongue Virus in Gansu Province, China

Huang Xiu\*, Pu Shuying†, Er Chengjun\*, Yang Chengyu†, Wei Wanlian\*, Cheng Xiengfu†, Zhang Chongxin\*, Li Xiaocheng† and Liu Tianbin\*

## Abstract

Serological testing in Gansu Province from 1981 to 1982 showed that 28/6488 (0.4%) cattle and 15/6073 (0.3%) sheep were positive for bluetongue group antibodies as indicated by agar gel immunodiffusion (AGID). A virus isolated from cattle was found to show bluetongue virus (BLU) characteristics by electron microscopy, polyacrylamide gel electrophoresis (PAGE), AGID and sheep inoculation. This was the first isolation of bluetongue virus from cattle in China.

BLUETONGUE virus (BLU) causes disease in sheep but is carried by cattle as a silent infection. Although it is therefore relatively difficult to isolate bluetongue viruses from cattle, this was achieved in this study.

## Materials and Methods

An epidemiological survey was carried out in 14 counties of Gansu Province and on Shandan Farm. Sera were collected from cattle and sheep in the same areas and testing for bluetongue antibodies was carried out by standard methods of agar gel immunodiffusion (AGID).

To attempt virus isolation, a heparinised blood sample was collected from a cow which tested positive by AGID on two occasions (Littlejohns 1981). The blood was lysed and used to inoculate BHK21 tissue culture. The cell sheets were examined daily for cytopathic effects (CPE) and blind passaged three or four times.

The virus was purified by ultracentrifugation and RNA-PAGE procedures (Cowley and Gorman 1988) then stained with phosphotungstic acid. The newly-isolated virus was inoculated into 3 one-year-old sheep which had tested negative for bluetongue antibodies. The inoculation dose of 3 mg of the ultracen-

trifuged virus was administered subcutaneously. The sheep were observed daily and their body temperature monitored. Blood was collected daily for seven days. A nucleic acid probe was used in a Dot-Blot test to assay the blood samples collected seven and eight days post-inoculation. The inoculated sheep were tested for specific bluetongue antibodies at 18 days post-infection.

## Results and Discussion

Gansu Province is located in the area between 32°31'–42°57'N and 92°13'–108°46'E. It comprises a high plateau with a complex geological structure. *Culicoides* biting midges are active in the area.

Sheep and cattle in 14 counties and on Shandan Farm were surveyed at random, showing that overall 28/6488 (0.4%) cattle and 15/6073 (0.3%) sheep were positive for bluetongue group antibodies by AGID (Table 1). In the mountainous area (Longnan County), 16/699 (2.3%) cattle and 9/619 (1.5%) sheep were seropositive. In a plains area (Shandan Farm), the prevalence was 8/108 (7.4%) in cattle. Most cattle were local breeds, with only two being crossbreeds.

The CPE in BHK21 cells commenced at 96 hours in the third passage and at 72 hours in the fourth passage. The CPE developed in the same way at the fourth passage level as standard bluetongue virus used as a control. The newly-isolated virus produced a standard positive reaction in a bluetongue AGID test when used as antigen.

\* General Veterinary Extension Station of Gansu Province, Lanzhou, 730046, People's Republic of China.

† Animal Quarantine Institute, Ministry of Agriculture, Qingdao, 266000, People's Republic of China.

**Table 1.** Results of serological survey for bluetongue antibodies by agar gel immunodiffusion (AGID) in cattle and sheep in Gansu Province.

Region	Cattle no. positive/no. tested (%)	Sheep no. positive/no. tested (%)	Total no. positive/no. tested (%)
Baiyin	0/413	0/407	0/820
Dingxi	0/410	0/460	0/870
Gannan	0/407	0/432	0/839
Jiayuguan	0/102	0/86	0/188
Jiuquan	1/601 (0.2)	1/581 (0.17)	2/1182 (0.2)
Jinchang	0/124	0/156	0/280
Lanzhou	0/766	0/730	0/1496
Linxia	0/506	0/500	0/1006
Longnan	16/699 (2.3)	9/619 (1.5)	25/1318 (1.9)
Pingliang	0/553	5/502 (0.1)	5/1055 (0.5)
Qingyang	3/591 (0.5)	0/601	3/1192 (0.3)
Shandan Farm	8/108 (7.4)		8/108 (7.4)
Tianshui	0/513	0/203	0/716
Wuwei	0/221	0/224	0/445
Zhangyie	0/474	0/572	0/1046
Total	28/6488 (0.4)	15/6073 (0.3)	43/12561 (0.3)

The virus was spherical, some 60–65 nm in diameter when photographed with an electron microscope (uranium acetate stain), and with a typical orbivirus structure. No other virus particles were seen. An RNA-PAGE preparation showed the 3.3.3.1 pattern typical of bluetongue.

No clinical signs were observed in any of the three sheep inoculated with the ultracentrifuged concentrate, and only one showed a rise in body temperature, to 40°C. This suggested that the virus of cattle origin was of low virulence for sheep. At 18 days post-inoculation, serum from the sheep with the temperature rise proved positive for bluetongue antibodies by AGID. This serum sample was also weakly positive in a Dot-Blot hybridisation with a cDNA probe. These results were consistent with the low virulence of the inoculum.

In summary, a bluetongue virus was isolated from a healthy cow in Gansu Province. This is the first isolation of bluetongue virus from a cow in China. The distribution of animals with bluetongue antibodies in Gansu Province varied with the terrain.

## References

- Cowley, J.A. and Gorman, B.M. 1988. Cross neutralisation of genetic reassortants of bluetongue virus serotypes 20 and 21. *Veterinary Microbiology*, 19, 37–51.
- Littlejohns, I.R. 1981. In: *Australia Standard Diagnostic Techniques for Animal Diseases*, 41.

# Bluetongue Epidemiological Survey and Virus Isolation in Xinjiang, China

Qin Qiying, Tai Zhengguo, Wang Lijin, Luo Zhengqi, Hu Jun and Lin Hanliang\*

## Abstract

An epidemiological survey of bluetongue was carried out in 17 counties of Xinjiang. Agar gel immunodiffusion (AGID) tests on 160 671 ruminant sera showed that the proportion of seropositives was highest in goats and declined through sheep and cattle, while all yaks and deer were seronegative. As positives were found as far north as 48°N, this survey has revised the thesis that bluetongue did not exist beyond 45°N. There was also confirmation of a relationship between the distribution of bluetongue and *Culicoides* insects as well as mosquitoes. Males of *Culicoides pseudosarinanus* Kieffer were first reported in Xinjiang. Bluetongue virus (BLU) was isolated, and identified by immunofluorescence antibody, electron microscopy, agar gel immunodiffusion (AGID) and polyacrylamide gel electrophoresis (PAGE) of the viral genome RNA. Neutralisation tests indicated that the virus was serotype 1 (BLU1). The virus strain was inoculated into goats, where it caused pathological changes in target organs of the foetus by crossing the placenta.

IN 1986, a general survey of animal diseases in Xinjiang identified bluetongue-seropositive goats, sheep and cattle in several counties, with a high incidence in some sheep and goat flocks. Seropositive goats, sheep and cattle were also found during veterinary quarantine inspection. To study bluetongue further in Xinjiang, an epidemiological survey and virus isolation and identification procedures were carried out.

## Materials and Methods

### Serological investigations

In 86 counties, sera samples were taken from ruminants, including 114 568 sheep and goats, 45 664 Yellow cattle, 372 yaks and 67 deer. Overall, 160 671 sera were tested by agar gel immunodiffusion (AGID) for bluetongue antibodies to enable epidemiological estimations. AGID bluetongue antigen and positive reference sera were provided by Yunnan Provincial Institute of Animal Husbandry and Veteri-

nary Science (YPIAHVS), and the Animal Quarantine Institute, Ministry of Agriculture, Qingdao.

As a natural infection experiment, goats and sheep that had proved seronegative after two serological tests two weeks apart were introduced into flocks with high bluetongue infection rates in Qunke Ranch, Weili County, before the mosquito and *Culicoides* activity season. Weekly blood samples were taken into anticoagulant (1 mL 7.6% sodium citrate plus 9 mL blood) and stored at 4°C. Sera were tested by agar gel immunodiffusion (AGID) to detect any seroconversion. Anticoagulant blood samples taken two weeks before seroconversion were used retrospectively for bluetongue virus (BLU) isolation. All introduced animals were examined clinically each week.

### Point monitoring of vector *Culicoides*

*Culicoides* were collected regularly at fixed points at Qunke Ranch, Weili County for species identification and to estimate prevalence.

### Virus isolation

Anticoagulant whole blood kept at 4°C was centrifuged at 1000 rpm for 10 minutes and the supernatant discarded. The sediment was reconstituted with minimal essential medium (MEM) to the original blood

\*Xinjiang Animal Quarantine General Station, Urumqi 830023, People's Republic of China.



volume, stored, and frozen and thawed twice to release virus particles. Before inoculation, a bacteriological examination was carried out, with penicillin and streptomycin (1000 iu/mL) added at the time of inoculation.

BHK21 cells were grown in a medium of equal volumes of 5% lactalbumin hydrolysate (Earle's) solution and Earle's MEM with 10% calf serum and an appropriate amount of antibiotics. When monolayers formed, they were inoculated with treated anticoagulant blood in the maintenance medium volume and incubated at 37°C for one hour. MEM mixture was then used as a maintenance medium, and the cells were examined for cytopathic effects (CPE) daily.

Seven- to eight-day-old chick embryos were each inoculated with 0.2 mL treated anticoagulant blood, incubated at 33.5°C and examined daily for seven days (Li Zhihua and Peng Kegao 1989). Chick embryos dying within 24 hours were discarded. Chick embryos dying after 24 hours were kept at 4°C and the dead embryos prepared in 1:5 saline emulsions, with penicillin and streptomycin added, and further passaged.

BHK21 cell-adapted virus was used to prepare the AGID antigen. Virus was harvested when cells had been cultured for 72 hours and CPE was evident. When the affected cells comprised more than 70% of the total, the cells were frozen and thawed three times, sonicated for 3 minutes, then centrifuged at 3000 rpm for 30 minutes. The deposit was discarded, and the supernatant was concentrated (100 fold) with polyethylene glycol (PEG) 2000 and inactivated with 0.01% sodium azide. The antigen prepared from isolated virus was tested with positive reference sera by AGID (Lin Lihui et al. 1989).

Cell-adapted virus smears and frozen sections of chicken embryo tissue virus were stained with fluorescein-labelled antiviral antibody (Anon. 1989). Hanging drops were negatively stained. Clarified tissue culture supernatant was absorbed onto carbon-coated copper grids. These were then absorbed with 1:10 rabbit-anti-sheep serum at 37°C for 30 minutes, followed by reaction with bluetongue antiserum at 37°C for 30 minutes, and then with the BLU test at 37°C for 30 minutes (BHK21). Cell-passaged virus culture suspension was frozen and thawed repeatedly, purified by centrifugation and chromatography, stained with 3% phosphotungstic acid, and examined using a DXB-12 transmission electron microscope adjusted to 300 000 total magnification (this work was done in cooperation with the Electron Microscopy Laboratory, YPIAHVS).

The positive cell cultures, as detected by fluorescent antibody and AGID, were purified as described by Wang Zheng (1989) to prepare viral nucleic acid, and run on polyacrylamide gel electrophoresis

(PAGE). Microneutralisation tests were conducted to identify the serotype of the isolated virus. Normal and healthy goats and sheep were inoculated with cell culture virus and examined clinically for pathogenic effects.

## Results

### Geographical factors

Xinjiang, in the centre of the Eurasian continent, is surrounded by high mountains: the Kumlun Mountains to the south, the Altai Mountains to the north and the Tianshan Mountains across the middle. These mountains divide Xinjiang into two greatly differing natural environments. North Xianjian is the semi-enclosed Zinger Basin, in the middle of which is the Gurbantong Youte Desert. South Xinjiang is the wholly-enclosed Tarim Basin, in the middle of which is the Takeria Magan Desert. In the three broad valleys are scattered Tulufan, Hami, Tacheng, Yanqi, Baicheng, Greater and Lesser Youdusi and Zhao Sucheng. Xinjiang is in the temperate zone with a continental dry climate, but with great differences between its north and south. The annual rainfall is 150–200 mm in the Zinger Basin (north Xinjiang), about 50 mm in the Tarlim Basin (south Xinjiang), but only 6.3 mm in Takexun County. In winter, north Xinjiang is cold while south Winjiang is relatively warm: in January the mean temperature is -12 to -17°C in north Xinjiang and -5 to -10°C in south Xinjiang. In summer, temperatures differ little, averaging 20–25°C in July in north Xinjiang, 25–27°C in south Xinjiang and up to 33°C in the Tulufan Basin. The frost-free period is short in north Xinjiang (about 150 days) and the mountain areas, and long in south Xinjiang and in the plains (about 200–220 days).

### Epidemiological survey

A sentinel herd was established in Weili County, Kuweilun District (844–932 m above sea level), close to the northern margin of the Kelamagan Desert. The average annual temperature is 10.3–10.6°C with extreme highs around 41.8°C. The mean temperature in January is -8.5°C to -10.2°C with extreme lows around -30.9°C. Annual rainfall is 36.6–52 mm, with annual relative humidity of 44%, and an annual evaporation capacity of 2252.3–2921.6 mm. In the Tarim Basin, the annual average temperature is 16°C.

*Culicoides* and mosquitoes are distributed widely in the north, and as far as the Tianshan Mountains in the south. There are 17 *Culicoides* species in Xinjiang, including *C. alexandrae* Dzharfarov, *C. circumscriptus*, *C. caucasicus*, *C. hamiensis*, *C. homotomus*, *C. liui* and *C. sinkiangensis*. The mosquito and *Culicoides* activity season occurs between May and September along the Tianshan Mountains in north

Xinjiang; between June and August in the northern part of north Xinjiang; and between April and August in south Xinjiang.

Of the 160 671 ruminants tested (including Yellow cattle, yak, sheep, goats and deer from 17 districts), 4053 (3%) were seropositive (average 2.5%). Among goats in the 42 counties investigated, 17% were seropositive: 1.8% of sheep (85 counties) and 0.9% Yellow cattle (86 counties) were seropositive. No seropositive yak or deer were found.

### Sentinel monitoring

The sentinel herd was located at Qunke Ranch, Weili County. This is situated in the valleys of the Peacock and Tarim Rivers, with a warm climate, and plenty of grasses, ponds, lakes and marshes full of reeds where large numbers of mosquitoes and *Culicoides* breed. The dominant species has been found to be *C. pseudosalinus* (82.8%) followed by *C. liui* (18%). *Culicoides pseudosalinus* appears in early May, and reaches peak density in late May or early June, while *C. liui* appears during the first ten days of May, reaches peak density in the second ten days of June, and disappears during the first ten days of August. The mean temperature in the peak density period is 25–28°C and wind is mild to non-existent (Qu Fengyi 1981).

Of the sheep and goats grazing together at Qunke Ranch, 51/98 sheep (52.8%) and 66/125 (52.8%) goats tested positive by AGID. Ten sheep and ten goats, tested negative to bluetongue by AGID, were introduced into the positive flock on 17 May 1989. Sera were collected regularly and tested from May 1989 to January 1990. Goat no. 29 became seropositive on 1 July 1989 and goats 26 and 27 on 8 July 1989 (Table 1). Anticoagulant blood from goats 26 and 27 were used for virus isolation. Although testing of the remaining goats and the sheep continued until the end of January 1990, none became seropositive.

Between May and December 1990, 115 sheep and goats, in mixed grazing in Xiaobaoxiang Township, Hami City, were examined for seroconversion. Tests on sera taken regularly from different animals of different ages and sexes showed that the seroconversion peak in Hami City occurred in June (56.3% of all positives; Table 2). Overall, seroconversion occurred in 27/99 (27.3%) sheep and 5/16 (31.3%) goats. Seroconverting sheep and goats were aged from one to six years old, showing that animals of various ages could be infected.

### Clinically suspected bluetongue cases

Six cattle at a breeding livestock farm in Bayinguolun Zhou in 1962 had swollen and bluish tongues, with evident cyanosis and congestion. Some sheep and goats in flocks had lost condition and wool. In January and February 1990, abortions of unknown

cause occurred in four flocks comprising 435 goats, which were grazing near Laobagongtai, Hejing Baluntai District. Of the 169 goats (38.8%) that aborted, 15/15 ewes tested negative for *Brucella*, 1/14 tested positive for *Toxoplasma*, and all 15 tested positive for BLU antibody by AGID. The aborted fetuses were abnormal, showing congestion and bleeding in skin, exophthalmos, hydrops abdominis, hepatomegalia and big hind limbs. In two counties of Akesu District, 364 sera from nine aborting goat flocks were tested, with a seropositive rate of 58%.

**Table 1.** Seroconversion of three sentinel goats tested for bluetongue antibodies by AGID, 1989.

Goat no.	Sex	17 May	1 Jul	8 Jul	17 Jul	25 Jul	2 Aug
26	female	-	-	+	+	+	+
27	male	-	-	+	+	+	+
29	male	-	+	+	+	+	+

+ seropositive  
- seronegative

**Table 2.** Bluetongue seroconversion of sentinel goats and sheep, by month.

Month	No. seroconverting	% of total seroconversion
June	18	56.3
July	2	6.3
August	6	18.8
September	3	9.4
November	3	9.4

### Virus isolation

Anticoagulant blood samples, taken one to two weeks before seroconversion of sentinel goats nos. 26 and 27, were inoculated onto BHK21 cells and examined daily. Cells of the first passage began to produce CPE in the third passage, with CPE becoming more extensive with increased passages.

Chick embryos were inoculated, via the yolk sac, with whole blood in anticoagulant of goats nos. 26 and 27, and examined daily. In general, virulence tended to increase with passage (Table 3), but until the eighth passage, pathological changes (congestion of chick embryo with oedema) were not regular.

Virus from blood of goats nos. 26 and 27 were adapted to BHK21 cells. The antigen prepared from the harvested cell-adapted virus 27F5 reacted with hyperimmune serum to Yunnan BLU strain, producing typical precipitating lines.

**Table 3.** Chicken embryo inoculation death rate.

F	Inoculation group	Control group
	Deaths/Total	Deaths/Total
26F1	1/5	
27F1	1/5	0/5
26F2	2/5	
27F2	4/5	0/5
26F3	1/5	
27F3	3/5	0/5
26F4	2/5	
27F4	3/5	1/5
26F5	2/5	
27F5	0/5	0/5
26F6	6/7	
27F6	5/7	0/5
26F7	1/5	
27F7	1/5	1/5
26F8	3/5	
27F8	0/5	0/5

Smears and sections, made from cell-adapted virus 26F3 and chick embryo passaged virus 27F6, were stained directly and examined by fluorescent microscopy. Typical fluorescent reaction (bright apple-green spots) could be seen in the cytoplasm. Fluorescence was clear in central vein walls and between hepatic cell cords of frozen chicken embryo liver sections.

Electron microscopy showed clusters of spherical particles with uniform size and structure. Capsids were clear, and there were antibody bridges between particles. Two kinds of particles, solid and hollow, could be seen. The morphology and size were identical to those of BLU, with a diameter of 60 nm.

RNA was shown to be separated into ten bands with a 3.3.3.1 distribution pattern, similar to that of BLU17, BTV-Y863 and BLU-W and quite different from that of epizootic hemorrhagic disease virus (EHD). The motility of RNA fragments was slightly different from that of the above bluetongue strains. Bands 4, 5, 6 in the isolate were divided equally, while bands 5 and 6 in the other strains were a little closer.

Normal, healthy goats and sheep were inoculated with cell-adapted virus 27F20. They showed temperature increases; persistent reduction of white blood cells with T and B lymphocytes in peripheral blood; haemorrhage; and lymphocyte and macrophage infiltration of various degrees in lymph node, spleen, tongue, buccal mucosa, pulmonary artery and corresponding organs in the foetus, suggesting the pres-

ence of BLU antigen in erythrocytes and target organs. The pathogenicity of bluetongue virus for sheep was higher than for goats, and, as the virus caused pathogenic lesions in the target organs of foetuses by crossing the placenta, the study revealed the association of abortion with BLU infection. There has been no report on the pathology of bluetongue in goats elsewhere in China.

The Xinjiang isolate 27F25 virus was tested against 24 South African BLU serotypes by neutralisation tests. The antiserum to BLU1 neutralised 100 TCID<sub>50</sub> of the Xinjiang BLU isolate. The control cells did not produce CPE, and the sera to other BLU serotypes did not neutralise the isolate, indicating that the Xinjiang isolate is BLU1.

## Discussion

Serological examination of 160 671 goats, sheep, Yellow cattle, yak and deer for bluetongue across Xinjiang showed different prevalences in most parts of Xinjiang, except the Ili, Boertara, and Tulufan Districts, with higher seropositive rates in Changji Zhou and Hami District. The seropositive rate in some goat and sheep flocks in a few counties may be as high as 50%. For example, 52.8% of goats in a flock of Qunke Ranch, Weili County, Bayinguolun District were seropositive, compared to only 0.1% of sheep in the Aletai District. Overall, goats were most likely to be seropositive (1789/10501; 17%), followed by sheep (1845/104067; 8%). The combined positive rate for sheep and goats was 3.2%. Cattle were rarely positive (149/45664; 0.9%), and no yak or deer had bluetongue antibodies. Seropositive goats, sheep and Yellow cattle were distributed mainly in the plains areas and in the margins of the Zinger and the Tarim Basins. This distribution is related to that of *Culicoides* and mosquitoes.

The Xinjiang BLU isolated from a goat has relatively high virulence for sheep and goats. Infected pregnant goat ewes and their foetuses were found to have significant anatomic lesions although they did not abort. The isolated virus passaged in BHK21 produced CPE, suggesting that it had been adapted to BHK21 cells. When it was inoculated into chick embryos, the isolate produced typical lesions and caused deaths, similar to that described by others. Cell cultures revealed evident fluorescent reaction. Clear precipitating lines appeared in AGID using antigen made from cell culture and BLU-positive serum. Immunoelectron microscopy of purified virus showed a morphology and size identical to that of BLU. Passage of the isolate in sheep revealed the characteristic features of bluetongue disease, but with some differences to those induced by Yunnan, Sichuan and Hubei BLU strains. In neutralisation

with sera against 24 South African serotypes, only serum to BLU1 neutralised the isolate. Nucleic acid electrophoresis revealed a band pattern of 3.3.3.1, similar to that of BLU but with minor differences among the strains. All these results showed that the virus isolated in this study was BLU1.

### Conclusions

A retrospective study of clinical signs of suspected bluetongue cases and the results of serological investigation have indicated that bluetongue has existed for a long time in the Xinjiang Uigur Autonomous Region. Serological (AGID) bluetongue surveys of 160 571 ruminants in 178 districts in Xinjiang Uigur Autonomous Region showed differing infection rates, with highest seropositive rates occurring among goats, followed by sheep and cattle. The distribution of seropositive animals was apparently influenced by different geographical conditions, climate, and *Culicoides* and mosquito activity. The virus isolated in this study was shown to be BLU1 through immunological assay, morphological observation, animal inoculation experiments, microneutralisation tests, nucleic acid electrophoresis and neutralisation tests.

### Acknowledgments

The Veterinary Service, Xinjiang Animal Husbandry Department gave significant support. Yunnan Provin-

cial Institute of Animal Husbandry and Veterinary Sciences, Harbin Veterinary Research Institute and Beijing Military Medical Research Institute were also very cooperative.

### References

- Anon. 1989. Draft procedure for the AGID test for bluetongue. *Yunnan Animal Husbandry and Veterinary Journal*, 4, 43-44.
- Lin Lihui, Huang Qiaoling, Kang Changfeng, Zhong Liying, Li Ping, Li Bing and Song Hang. 1989. Isolation of bluetongue virus and a serological survey in Sichuan Province. *Yunnan Animal Husbandry and Veterinary Journal*, 4, 57-60.
- Li Zhihua and Peng Kegao 1989. Direct isolation of bluetongue virus in tissue culture. *Yunnan Animal Husbandry and Veterinary Journal*, 4, 49-52.
- Qu Fengyi. 1981. *Acta Entomologica*, 3, 24.
- Wang Zheng. 1989. Polyacrylamide gel electrophoresis of rotaviruses 1986. Xinjiang 'August 1' Agricultural College.

### Bibliography

- Guo Zaijun, Hao Jucai, Chen Jianguo, Jian Zuoming, Li Zhihua, Zhang Khaili, Hu Yuling, Li Gen and Pu Long. 1989. Report of bluetongue disease survey in Bayannur Meng, Inner Mongolia. *Yunnan Animal Husbandry and Veterinary Journal*, 4, 53-56.
- Hu Yuling and Peng Kegao. 1989. SDS-PAGE analysis of four bluetongue strains recovered in China. *Yunnan Animal Husbandry and Veterinary Journal*, 4, 49-52.

# The Isolation and Characterisation of Bluetongue Virus and Its Epidemiology in Shanxi Province, China

Lei Huaimin, Xu Jianming, He Chongli, Shao Jiangliang and Shi Xiayun\*

## Abstract

After the first report of bluetongue north of the Yellow River, an epidemiological survey involving 13 858 ruminants in 11 regions/cities and 50 counties was conducted. Bluetongue disease, with typical symptoms, occurred in epidemic sites in the mid-west and south of Shanxi, involving four small towns and 22 villages. At two outbreak sites, morbidity rates were 8.6% and 22.9% respectively and mortality rates 32.6% and 16.0% respectively. The seropositive domestic ruminants, with both active and silent infections, were mainly in the Lu Liang mountains and hills in southern Shanxi. The highest rate of positives was found among goats (35%), followed by sheep (8.2%) and cattle (7.8%). Infection occurred mainly in August and September, the active season for the vector *Culicoides*. Bluetongue serotype 1 (BLU1) was isolated and used to make a vaccine. Sheep from infection-free areas brought into infected areas acquired bluetongue infection. Management of the disease requires limitations on livestock movements, elimination of *Culicoides*, a vaccine and hygiene measures.

THE first outbreak of bluetongue virus (BLU) in China occurred in Yunnan, with BLU subsequently isolated in Guangdong, Guangxi, Hubei, Anhui, Sichuan, Inner Mongolia, Hebei, Jiangsu and Liaoning. However, clinical signs of bluetongue were seen only in Yunnan, Sichuan, Anhui and Hubei because bluetongue vectors, *Culicoides* species, are confined to the southern areas, reaching as far north as 40°N. Bluetongue outbreaks occurred close to that zone. Contagious disease in sheep with suspected bluetongue symptoms occurred in the Jiaocheng and Yangcheng regions of Shanxi Province from August to September 1991 and in October 1993 respectively. The virus causing the disease was identified as BLU after a comprehensive investigation, reported here, involving the isolation, identification and epidemiological study of bluetongue viruses in Shanxi Province, China.

## Materials and Methods

Specimens for diagnosis were obtained from whole blood and sera of sick sheep collected on days 4, 5, 7, 10, 15 and 40 after initial symptoms. Samples of heart, lung and blood vessel lesions from critically ill animals were also collected. Specimens for virus isolation were inoculated into cells, blind passaged homogenates of embryonated chick embryos (ECE; provided by General Epidemic Prevention Station of Shanxi Province).

Vero and BHK21 cells were provided by National Quarantine Institute and National Veterinary Medication Institute. Experimental sheep were purchased from bluetongue epidemic-free areas and confirmed as AGID negative. Bluetongue standard antigen plus positive and negative controls were provided by the National Quarantine Institute. Eight- to ten-day-old ECE and experimental mice were supplied by Guandi chicken breeding farm and the Shanxi Medicine College.

Epidemiological surveys involved a general survey and case reports when two outbreaks occurred. The

\* Veterinary Prevention and Treatment Station of Epidemic Diseases of Domestic Animals, Shanxi Province, Ta Yuan 030001, People's Republic of China.

clinical symptoms of sick sheep, and pathological changes postmortem, were recorded.

Blood cells collected from sick sheep with typical clinical signs were washed three times with saline and inoculated intravenously into 6- to 7-day-old ECE with 0.2 mL blood cells. After incubating for a further three to five days, the whole embryo amnion and the fluid inside were harvested and stored at  $-20^{\circ}\text{C}$  until required.

Monolayers of Vero or BHK21 cells were inoculated with either 0.2 mL blood cells or ECE homogenate, then incubated at  $35^{\circ}\text{C}$  and blind passaged. The supernatant from the cell cultures with uniform typical cytopathic effects (CPE) was then harvested.

In attempts to isolate the virus, Vero or BHK21 monolayers were inoculated with either whole blood from sick sheep or the ECE specimen after blind passage. The resultant isolates were sent to Yunnan Tropical and Subtropical Animal Virus Diseases Laboratory (YTSAVDL) for identification.

Ten healthy, one-year-old male sheep, from bluetongue-free areas and individually AGID negative, were inoculated under the skin in the groin area with 0.5–1 mL of diluted blood cells from sick sheep or cell culture. Clinical signs and body temperature were recorded daily.

## Results

### Epidemiological survey of two epidemic areas of Shanxi site descriptions

#### *Jiaocheng region*

Located in a mountain valley at  $112^{\circ}$ – $112^{\circ}30'$  E,  $37^{\circ}30'$ – $38^{\circ}$  N; 2000 m above sea level; four distinct seasons; average annual temperature  $8.5$ – $9.5^{\circ}\text{C}$  (max  $32.5^{\circ}\text{C}$ , min  $-20^{\circ}\text{C}$ ), average relative humidity 70% and average rainfall 520.6 mm.

#### *Yangcheng region*

Located in a hilly land area between  $112^{\circ}$ – $112^{\circ}30'$  E,  $35^{\circ}$ – $35^{\circ}30'$  N; 600–1500 m above sea level, similar climate to Jiaocheng, with dry spring and wet

autumn; average annual temperature  $10$ – $12^{\circ}\text{C}$ ; average rainfall 650–850 mm.

### Epidemiological survey outbreaks of bluetongue

#### *Jiaocheng region*

In mid-August 1991, a bluetongue-like disease first occurred in Huijiashuan village, peaking at the beginning of September and declining by the end of the month. The disease was epidemic in an area covering 56 flocks of sheep belonging to 19 villages and three communes. Of the 1125 sheep at risk, 428 (38%) became sick and 98 (22.9%) died. None of the 3825 goats raised in the area became sick. Most sick sheep were more than 1 year old.

#### *Yangcheng region*

Three flocks of 133 sheep and 16 goats were in the area. Of these, 56 sheep (32.6%) became sick and 9 (6%) died. No clinical signs were seen in the goats.

Although many blood-sucking insects, such as mosquitoes and *Culicoides*, existed in both epidemic areas, these had nearly disappeared during the bluetongue outbreak period because of cold weather. All sick sheep had an increased body temperature ( $39.5$ – $40^{\circ}\text{C}$ ) with acute typical clinical signs found in the mucosa of the mouth and in most of the digestive, respiratory and cardiac systems. The course of the disease ran from eight to ten days, with sudden death often occurring after two to three days. A high abortion rate occurred on the Kelan cashmere goat breeding farm (a main flock) and in areas that introduced breeders from Kelan (Table 1).

### Serological survey

A general serological survey using the AGID test throughout Shanxi province showed that, in descending order of prevalence, goats (including cashmere goats), sheep and cattle were antibody positive (Table 2).

### Animal infection experiment

The number of leucocytes in blood samples and the body temperatures of infected experimental sheep are

Table 1. Abortion rate of ewes in the bluetongue epidemic area

Farm	Year	Total no. of ewes	No. of pregnant ewes	No. of pregnant ewes aborted (%)	No. of pregnant ewes dying
Kelan Breeding Farm*	1991	1100	1000	150 (15.0)	30
	1992		350	88 (25.0)	1
Surrounding farms**	1991–1992		4000	1043 (33.8)	–
Wujiaping Village	1991–1992	149	130	100 (76.9)	–

\* breeding goats supplied by Kelan farm

\*\* one of the surrounding farms

shown in Tables 3 and 4. Blood samples from all experimental sheep were AGID positive on 17 January 1994. BLU was isolated from all specimens and was identified by YTSVDL as BLU1.

## Discussion

Epidemiological and serological surveys showed that bluetongue existed in Shanxi Province, with

**Table 2.** Serological survey by AGID test in Shanxi Province.

Region/survey unit	No. surveyed	Animal	No. of animals tested	No. of positive animals	Positive rate %	Remarks
Jiaocheng region (farms)	15	sheep	727	163	22.4	total of 58519 sheep; outbreak site
		goats	1911	730	40.3	
		cattle	37	6	16.2	
Breeding farms	12	sheep	244	total 103	9.9	animal species mentioned
		goats	260			
		cattle	540			
Neighbouring counties to Jiaocheng	11	sheep	total 4814	128	2.3	high positive rates in samples from mountain area
		goats		4648	28.3	
		cattle		735	39	
Animal base farm	40	sheep	1518	2	0.13	Cashmere base farm - 13, 11 sheep, 16 cattle.
		goats	2207	804	36.4	
		cattle	500	3	0.6	
Yangcheng region	3 (villages)	sheep	30	11	36	year of outbreak
			20	7	35	1.5 years after outbreak

**Table 3.** Normal physiological parameters of experimental sheep (measured 24 December 1993).

Sheep no.	Physiological parameter of experimental sheep			
	Respiratory rate (breaths/min)	Body temperature (°C)	Heart pulse (beats/min)	No. leucocytes/mm <sup>3</sup> blood
1	20	39.8	78	8550
3	16	39.5	70	7800
4	18	39.8	80	9300
5	17	39.6	75	8900
7	16	39.5	77	10900
8	14	39.3	73	8800

**Table 4.** Changes in major physiological parameters after inoculation of specimen.

Date	Inoculum* Animal no.	20 Dec 1993	2 Jan 1994		4 Jan 1994		6 Jan 1994	11 Jan 1994
		Body temperature °C	Body temperature °C	Leucocytes/mm <sup>3</sup>	Body temperature °C	Leucocytes/mm <sup>3</sup>	Body temperature °C	Body temperature °C
Blood cells	1	36.6	41.9	4025	40.2	6550	39.6	39.2
	3	36.6	38.9		38.4		38.6	38.4
ECE	4	38.9	36.4		38.0	7950	38.5	38.2
	5	40.4	39.2		39.0	5000	38.9	38.7
Cell culture	7	39.6	39.4		39.0		38.9	38.0
	8	39.4	39.7	10700	38.7	10700	38.8	38.5

\* See text for description of preparation of specimen

most epidemic sites in mountainous and hilly parts where there were active *Culicoides* and other blood-sucking insects. The epidemic season for bluetongue was from mid-August to the beginning of September, although scattered infections occurred up to October (that is in late summer and early autumn). This pattern is slightly different from the reports from elsewhere in the world. There were predictable signs for the acute outbreak of bluetongue disease, with typical clinical symptoms. This suggests that bluetongue could spread north of the Yangtze River.

The source of bluetongue in Shanxi Province was suspected to be within Gaixian County in Liaoning

Province, as some breeding cashmere goats had been introduced from there to the Kelan Goat Breeding Farm. The latter, in turn, may have been the source of bluetongue in Shanxi. The most susceptible species in Shanxi was the cashmere goat, unlike other provinces where the highest prevalence of bluetongue was in sheep. The phenomenon of a high abortion rate in ewes may be related to infection with BLU viruses, but this aspect needs further study.

Overall, this serological survey showed that some parts of Shanxi Province remain free of bluetongue, so that prevention and quarantine should be urged immediately.



# A Serological Survey of Bluetongue in Cattle in Guangxi Province, China

Chen Libiao, Zhong Peiyi and Zhao Guoming\*

## Abstract

In 1985, 14 purebred cattle, including four imported from Pakistan, were tested for bluetongue group antibodies using agar gel immunodiffusion (AGID). Four animals tested positive. Subsequently Guangxi Veterinary Epidemic Prevention and Quarantine Station used AGID to test 766 cattle from different areas in Guangxi, including eight regions and three cities. The serum samples were collected from Guangxi Animal Husbandry Research Institute, in cooperation with Kunming Animal and Plant Quarantine Service and the Yunnan Animal Husbandry and Veterinary Research Institute. Of the 766 cattle tested, 88/766 (11.5%) were positive and four suspect. Three regions and one city had no positive results. The highest positive rate (13/18; 72%) was found in the Hechi region. Between 1987 and 1990, a larger scale serological survey was carried out in 30 Guangxi counties. Of the 3712 animals tested, 1328 (35.8%), in 29 counties, were AGID positive. However, extensive investigations through veterinarians failed to find any report of bluetongue disease in cattle or sheep. Bluetongue virus has not yet been isolated. Further research will be carried out to discover why the bluetongue positive rate is so high in cattle in Guangxi: some cross-reaction with epizootic hemorrhagic disease (EHD) virus is considered possible.

THE first report of bluetongue in China came from Yunnan Province in 1979. This paper describes a major survey conducted from 1987 to 1989 in Guangxi Province.

## Materials and Methods

In 1985 14 purebred cattle, including four bulls from Pakistan, were tested for bluetongue by agar gel immunodiffusion (AGID). When positive reactions were found, a wider survey was made of 766 cattle and buffalo from eight regions and three cities in Guangxi. Between 1987 and 1990, a larger and more representative survey was carried out on 3712 cattle from 30 counties and 23 special breeding farms in Guangxi province. The sera were stored at 4°C until tested. Control sera and AGID antigen were provided by Yunnan Tropical and Subtropical Animal Virus

Diseases Laboratory. Tests were conducted according to the standard protocol. Tests giving suspect results were repeated.

## Results

Of the 14 purebred cattle tested in 1985 by Zhong Peiyi and others, four were positive. In the preliminary survey, 87/766 (11.5%) of cattle were positive, and four suspect. The prevalence in local breeds was slightly higher (15%) than in introduced breeds and crossbreeds (5–10%). Prevalence was highest (44.6–55.7%) in the southeastern and coastal areas including the Yulin, Wuzhou, Nanning and Qinzhou regions, while the lowest prevalence (14.5–16.9%) was in the northern areas, including Guilin and Liuzhou region. The western part of the Province had an intermediate prevalence. The highest prevalence recorded was in the Hechi region at 13/18 (72%). All animals from which blood was collected were healthy.

In the larger survey, 1328/3712 (35.8%) were positive, with AGID-positive animals being found in 29

---

\* Guangxi Veterinary Prevention and Quarantine Station, Nanning 530001, People's Republic of China.

(96.7%) of the 30 counties tested (Table 1). The survey covered all eight regions of Guangxi Province and the three large cities of Guilin, Liuzhou and Beihai: prevalence in the cities ranged from 5.6% to 77.8%.

**Table 1.** Results of serological survey using AGID in different regions of Guangxi Province, 1987–1990.

Region	No. of counties tested	No. of blood samples	No. of positive sera (%)
Bose	4	403	137 (34.0)
Breeding farm	23	575	209 (36.3)
Guilin	4	425	72 (16.9)
Hechi	3	308	118 (38.3)
Liuzhou	4	425	62 (14.5)
Nanning	4	409	175 (42.8)
Qinzhou	4	427	196 (45.9)
Wuzhou	4	422	188 (44.6)
Yulin	3	318	171 (53.8)
Total	30 (plus 23 breeding farms)	3712	1328 (35.8)

## Discussion

The AGID test (Anon 1989), widely used in serological surveys for bluetongue, was used for preliminary tests of 766 cattle and 4 bulls before the large scale survey. The preliminary work showed that the method was suitable for wider ranging sampling. The survey, carried out in all regions of Guangxi, showed that there was bluetongue antibody in most of the Province except for three regions and one large city (Beihai). Thus it was confirmed that bluetongue infection was widespread in the cattle of Guangxi Province. Although no clinical signs were found, cattle could be a large potential source of virus for epidemic outbreaks in this Province.

Guangxi Province is located in the southern part of China, where there is a subtropical monsoon climate with high temperatures, relative humidity and rainfall. This is a suitable habitat for bloodsucking insects such as mosquitoes and *Culicoides*. The natural environment explains the prevalence of bluetongue virus in Guangxi. There is also a lack of proper quarantine, prevention strategies or monitoring of the bluetongue status of introduced breeds from outside the Province. As the survey showed such a high prevalence of bluetongue group antibody in cattle which had no clinical signs, it is highly possible that there may be cross reactions between bluetongue viruses and other species of orbivirus, such as epizootic hemorrhagic disease (EHD) virus. This aspect needs further research.

## Reference

- Anon. 1989. Draft procedure for the AGID test for bluetongue. *Yunnan Animal Husbandry and Veterinary Journal*, 4, 43–44.

# Serological Survey of Bluetongue in Sheep and Cattle in Inner Mongolia

Mo Regen, Ao Fulai, Si Qin and Zhao Xinli\*

## Abstract

The prevalence of infection of bluetongue in sheep and cattle in Inner Mongolia was determined by agar gel immunodiffusion (AGID). In all, 6712 serum samples were tested. The positive rates were 14.8% in 4098 introduced sheep; 74.7% in 463 breeding sheep; and 67.6% in 2004 goats. However, 316 sera from cattle tested negative, as did 103 samples from sheep in an area without introduced sheep. The results indicated that the prevalence of bluetongue antibodies was higher in breeding sheep and goats than in introduced sheep.

SINCE the first discovery of bluetongue in China by Yunnan Provincial Institute of Animal Husbandry and Veterinary Science (YPIAHVS) in 1979, cases of seropositive animals have been detected in other provinces and municipalities, and different strains of bluetongue virus (BLU) have been successfully isolated. In 1986, a quarantine inspection in the Bayannur Meng of Inner Mongolia detected BLU antibody in goat serum, using agar gel immunodiffusion (AGID), and BLU was isolated and identified in collaboration with YPIAHVS. To ascertain further the distribution and prevalence of bluetongue in Inner Mongolia, and to provide a scientific basis for control of the disease, a serological survey of bluetongue was carried out in various districts

## Materials and Methods

Serum samples were randomly collected from goats, sheep and cattle in nine districts or cities in Inner Mongolia. Samples of whole blood were collected using routine methods and sera were stored at 4°C until used. Reference antigen and bluetongue positive serum were provided by YPIAHVS. The testing methods and reading followed 'Procedures of agar

gel immunodiffusion test for detection of bluetongue' developed by YPIAHVS (Zhang Nianzu et al. 1989a).

## Results

*Breeding sheep:* of the 463 sera samples tested, 346 (74.7%) were positive.

*Goats:* in areas where breeding animals had been introduced, 1305 (65.1%) of 2004 sera were positive.

*Sheep and goats:* in areas where breeding animals had been introduced, 609 (14.86%) of 4098 sheep sera were positive. In areas where breeding animals had not been introduced, all 103 sheep and goat sera tested were negative.

*Cattle:* all 316 cattle sera, collected in different districts, tested negative.

## Discussion and Conclusions

Bluetongue in Inner Mongolia has wide distribution and high prevalence. The highest infection rates were in breeding sheep (74.7%) and goats (65.1%). The infection rate was lower in sheep (14.8%). As these seropositive rates were greater than those detected in Yunnan Province in 1983 by Zhang Nianzu et al. (1989b) and in Bayannur Meng, Inner Mongolia in 1986 by Guo Zhaijun et al. (these Proceedings), the disease may be increasing in the region.

\* Inner Mongolia Veterinary Station, Huhhot 010010, People's Republic of China.

Our results also revealed that seropositive animals appeared to occur mainly in areas where breeding animals had been introduced or where breeding sheep and goats were raised, indicating that the presence and spread of bluetongue were associated with the introduction of breeding animals, mating during the *Culicoides* activity season, and movement of livestock herds.

The emergence and spread of bluetongue has caused great losses in livestock production in Inner Mongolia. We therefore recommend that effective measures be taken, including strict animal quarantine and prohibition of the introduction of seropositive animals. At the same time, seropositive breeding animals should be culled out. In seasons of *Culicoides* activity, measures should be taken to prevent infec-

tion of normal breeding animals, and movement of positive livestock should be restricted. Research and application of immunisation measures should be undertaken in a planned way.

## References

- Zhang Nianzu, Zhang Khaili, Li Zhihua, Hu Yuling, Li Gen, Zhao Kun, Zhou Fuzhong and Shanyu Naishun. 1989a. Application of agar gel immunodiffusion test for the diagnosis of bluetongue in animals. *Yunnan Animal Husbandry and Veterinary Medicine*, 4, 17-19.
- Zhang Nianzu, Zhang Khaili, Li Zhihua, Shanyu Naishun, Hu Yuling, Li Gen, Zhao Kun, Zhou Fuzhong and Xu Wenzhen. 1989b. Investigation and study of bluetongue disease of sheep in Yunnan, China. *Yunnan Animal Husbandry and Veterinary Journal*, 4, 3-12.

# Investigation of Bluetongue Disease in the Bayannur Meng of Inner Mongolia

Guo Zhaijun\*, Hao Jucai\*, Chen Jianguo\*, Li Zhihua<sup>†</sup>, Zhang Khaili<sup>†</sup>,  
Hu Yuling<sup>†</sup>, Li Gen<sup>†</sup> and Pu Long<sup>§</sup>

## Abstract

Serological testing for bluetongue antibodies was carried out by agar gel immunodiffusion (AGID) in seven cities and counties of the Bayannur Meng of Inner Mongolia. Among the samples from sheep, goats, Yellow cattle and camels, 23.2% (650/2799) were seropositive. This proportion was higher among goats at 57.9% (523/903) and lower among sheep at 7.5% (127/1684), with no positive reactions found at all in camels. The seropositive sheep and goats showed no clinical signs. However, some sheep and goats in a sentinel herd showed elevated temperatures and changes in white blood cells. Through the use of sentinel herds, bluetongue disease was found to occur under natural conditions in Bayannur during an epidemic period. Within the sentinel herd, the seropositive rate was 59.2%. After inoculation of embryonated chicken eggs and cell cultures as well as sheep experiments, bluetongue viruses were isolated from sheep. These isolates were shown to be the same group as the Yunnan strain and USA BLU17.

BLUETONGUE disease is well described from other countries (Bowne 1971; Anon. 1980). After the isolation of bluetongue virus (BLU) by Yunnan Provincial Institute of Animal Husbandry and Veterinary Science in 1979 (Zhang Nianzu et al. 1989b), bluetongue viruses were isolated in Hubei in 1984 and Sichuan in 1988 (Lin Lihui and Li Zhihua 1989). In 1986, the Inner Mongolian Animal Quarantine Station, while conducting import and export quarantine inspections in Bayannur Meng, detected bluetongue antibodies in 53.2% (298/549) of goats tested by agar gel immunodiffusion (AGID). To investigate further the presence and prevalence of bluetongue in Bayannur Meng, and to provide a scientific basis for control of the disease, the Bayannur Veterinary Station, in collaboration with Yunnan Provincial Institute of Ani-

mal Husbandry and Veterinary Science (YPIAHVS), carried out an epidemiological survey and virus isolation and identification program between 1986 and 1988.

## Materials and Methods

### Epidemiological survey

Between April and July 1987, goats, sheep, Yellow cattle and camels were randomly selected in 32 Sumu (townships) and breeding farms in the district for investigation by AGID. Statistical and comparative analyses were made of the test data in terms of range of infection, area, and animals and their ages.

Between April 1987 and January 1988 (before the start of the activity season of the vector *Culicoides*), 50 seronegative goats and 10 seronegative sheep, from agricultural and pastoral areas, were introduced into herds with a 50% bluetongue seropositive rate. All animals grazed together and were observed for natural infection. During the experimental period, the introduced animals were tested weekly by AGID and infection rates were calculated monthly. Clinical signs were recorded. Whole blood samples were taken aseptically with 1/10 (v/v) in

\* Bayannur Meng Station of Veterinary Medicine, Linhe 015500, Inner Mongolia, People's Republic of China.

<sup>†</sup> Yunnan Tropical and Subtropical Animal Virus Diseases Laboratory, Jindian 650224, Kunming, People's Republic of China.

<sup>§</sup> Inner Mongolia Station of Veterinary Medicine, Hohhot, 010010, People's Republic of China.

anticoagulant (7.5% sodium citrate) from confirmed infected goats and sheep, and stored at 4°C for later use.

Antigens, positive reference sera and negative sera were provided by the YPIAHVS. Test sera were prepared and stored in a routine manner. Tests were performed and read in accordance with procedures developed by the YPIAHVS (Zhang Nianzu et al. 1989a).

### Virus isolation and identification

#### *Passage in embryonated chicken eggs*

Sodium citrate anticoagulant blood from infected animals was washed off the red blood cells with sterile normal saline. Sterile distilled water was used to replace the original volume of blood for lysis. The lysed red blood cells were used to inoculate five to ten 7-day-old embryonated chicken eggs (ECE) in the yolk sac (0.2 mL inoculum for each), or to inoculate 0.02 mL inoculum intravenously into 10- to 12-day-old ECE with five uninoculated chicken embryos as control. The inoculated eggs were examined twice daily. The dead ECE were collected, after being confirmed free of bacteria by bacteriological examination. Sterile normal saline was added and the material ground to prepare a 1:5 emulsion, which was then stored at 4°C for 12–24 hours and passaged in ECE as above. Observations of embryo death were made for 48–120 hours. Whether there were reaction or deaths, the embryos were blind passaged five to eight times before final examination. Eggs which died in a regular pattern were kept at 4°C for further virus isolation attempts.

#### *Cell Culture*

BHK21 cells were dispersed and grown in Eagle's media according to routine methods. When monolayers were confluent, they were inoculated with 0.1 mL 1:5 emulsion prepared by grinding the infected ECE in normal saline, and were blind passaged until typical cytopathic effects (CPE) appeared.

#### *Experimental artificial infection of goats and sheep*

Eight seropositive anticoagulant goat blood samples were taken and mixed in pairs, to give four goat blood inocula. Each blood mixture inoculum was used to inoculate one sheep: eight sheep in all were inoculated with 1 mL each. The inoculated sheep were examined for temperature rises, changes in white blood cell counts etc.

#### *Sheep (goat) virulence test*

Each animal was subcutaneously inoculated with 10 mL isolated virus in cell culture suspension, examined daily for clinical signs, and subsequently tested by AGID.

### Virus identification

#### *Group specificity test*

The virus cell culture was frozen and thawed three times, then concentrated 100-fold to prepare soluble antigen. Positive reference serum was used to carry out the AGID test (Zhang Nianzu et al. 1989a), and control antigens were prepared from Yunnan strain and US BLU17. The virus cell culture sediment was directly stained with fluorescent antibody, as provided and described by YPIAHVS (Hu Yuling and Peng Kegao 1989), and then examined under a fluorescence microscope.

The virus cell cultures were concentrated by treatment with Freon (Hu Yuling and Peng Kegao 1989; Hu Yuling et al. 1989), negatively stained with phosphotungstic acid and examined by electron microscopy for virus morphology. Virus was purified to prepare nucleic acid, analysed with SDS-PAGE (Hu Yuling et al. 1989) and compared with domestic bluetongue isolates and with BLU10 and 17 from the USA.

## Results

### Epidemiological survey

Bayannur Meng is situated in the western part of the Inner Mongolia Autonomous Region, between 40°13'–42°28'N and 105°21'–109°53'E, and has a total area of 64 413 km<sup>2</sup>. The Yinshan mountain range crosses the whole district. North of the mountains is a highland pastoral area (1100–1500 m above sea level), with a medium temperate and highland climate, a frost-free period of 130–160 days and an annual rainfall of 140–250 mm. The activity season of local insects (mosquitoes, flies, gadflies, mites and *Culicoides* midges) falls between April and October. In 1987, the livestock population of Bayannur Meng comprised 4 134 million animals: this included 2013000 sheep, 314 000 goats, 545 000 Yellow cattle and 25000 camels. A relatively rough grazing regime is practiced.

In all, 2799 ruminants were sampled by AGID for the presence of bluetongue antibody. Overall, 23.2% (650) were seropositive: this proportion was higher among goats at 57.9% (523/903) and lower among sheep at 7.5% (127/1684). The situation was basically identical to results from Yunnan Province (Zhang Nianzu et al. 1989b) where no clinical signs of bluetongue were found in either sheep or goats. Follow-up investigations revealed no clinical signs of disease similar to bluetongue. No antibodies were detected in 100 Yellow cattle and 112 camels.

Serological investigations showed that the infection rate was higher in the pastoral areas, at 37.6%, than at the interface of agriculture and pastoral areas,

at 28.1%. No bluetongue antibodies were detected in goats and sheep born in the Hetao (Yellow River Bend) agricultural zone. Follow-up studies showed that the seropositive animals were adult sheep and goats purchased from pastoral areas. The infection rate among goats, mainly purchased animals, was 10.5%.

Statistical analysis of the infection status of 737 goats and sheep of different ages showed that animals above three years old were more likely to be infected than two-year-old animals, and both groups were more likely to be infected than one-year-old animals.

All 60 goats and sheep tested between April and July were seronegative. From August on, however, seropositive animals were detected. Although most seroconversions were detected between August and October, newly positive animals were detected even as late as January in the following year. No clinical signs were observed in the infected animals during the experimental period. A few animals showed transient temperature rises (to 40°C) and reductions in numbers of white blood cells by 25–50%.

#### Virus isolation and identification

After five passages, regular deaths occurred in the ECE, with significant oedema in corresponding parts of the chicken embryos. Chicken embryo virus from blood sample no. 018 was used to inoculate BHK21 monolayers. After five passages, CPE appeared. Intercellular gaps were slightly broadened after continuous culture for 48 hours. Approximately one third of the cells became rounded and detached in 72 hours. All the cells finally rounded, aggregated and fell off the glass.

Sheep no. M2, inoculated with a mixture of anticoagulant bloods nos. 003 and 017, exhibited seroconversion, with a transient reduction of white blood cells and a temperature rise 22 days post-infection. The sheep inoculated with a mixture of anticoagulant bloods nos. 018 and 019 seroconverted, with mild changes in white blood cells and temperature 22 days post-infection. Seroconversion was not observed in the other infected sheep during one 1 month of observation post-infection. One of the two sheep inoculated with cell culture of the isolated virus seroconverted 15 days post-infection, without significant change in white blood cell count and temperature.

#### Virus identification

Antigen was prepared using BHK21 cell cultures infected with the virus isolate. An AGID test was conducted with the prepared antigen and reference positive serum. A positive result was obtained, with the control antigen remaining negative.

BHK21 cell cultures with the isolated virus were stained directly with fluorescent antibody. Fluores-

cent microscopic examination of the preparation demonstrated apple-green fluorescence in stained substances of various sizes in the cytoplasm surrounding the nucleus. The standard viruses (Yunnan strain, Wuhan strain and USA strains) were prepared as reference material. The results were identical. No fluorescence reaction was found in cell cultures not infected with virus.

Viral particles were observed by electron microscopy. These particles were round in form with significant structure at an electronic amplification of 20000 and a five-fold optical amplification. The structure of the preparation was the same as those of the reference virus (US BLU17). The nucleic acid could be divided into 10 RNA fragments, and the band pattern was the same as those of the Yunnan strain, US BLU10 and 17.

### Discussion

According to previously published accounts, the approximate distribution of bluetongue is between latitudes 45°N and 45°S (Bowne 1971; Sellers 1981). Bayannur Meng is located between 40–42°N and is thus clearly within the bluetongue epidemiological region. Our serological investigations showed the average prevalence of bluetongue antibodies in Bayannur Meng was 23.2%, with 7.5% in sheep and 57.9% in goats. No bluetongue antibody was detected in the Hetao (Yellow River Bend) agricultural area: whether this is due to a variance of geographical or ecological conditions remains to be investigated.

Among sentinel herds, AGID testing revealed a seroconversion rate of up to 59.2% (28/50 in goats and 4/4 in sheep), indicating that the infection rate was relatively high in an epidemiological cycle. Seroconversion occurred until December of the same year and even in January of the following year. This was probably because infection with trace amounts of virus induced only small amounts of antibodies which could not be detected. The virus then multiplied with prolonged viraemia, resulting in a gradual increase of antibody titre. In our experiments, we observed that antibodies were not detected in goats inoculated with test blood until 116 days later. Furthermore, 8/31 sheep showed seroconversion in December when the extreme cold would suggest there is no *Culicoides* activity. Whether there is another insect vector remains to be determined.

The virus isolated was confirmed as being BLU as it caused CPE in cell cultures, regular deaths and lesion in inoculated chicken embryos, and seroconversion as detected by AGID in experimentally infected animals. Group-specificity determinations, morphological examination and epidemiological data also confirmed the BLU identification.

A virus strain of relatively low virulence was isolated from a goat and from sheep. The infection rate was low in sheep, including pedigree breeds such as Xinjiang fine-wool and Romney sheep. No antibodies were detected in Yellow cattle. It therefore appears that the virus isolated in Bayannur Meng differs from other bluetongue viruses isolated from sheep in China. Whether this is the goat-adapted virus or a hypovirulent sheep strain remains to be investigated. No antibody and no clinical cases were found in cattle where goats were heavily infected. No cross-reaction was found between the positive serum and epizootic hemorrhagic disease (EHD) virus, suggesting that Ibaraki disease in Yellow cattle could be excluded.

Analysis of the isolate's nucleic acid showed that the isolated virus had 10 nucleic acid fragments, with a band pattern similar to that of known bluetongue virus types, indicating that the virus was a bluetongue virus, not a bluetongue-related virus. Study of its type-specificity will be carried out elsewhere.

No previous report has been seen on the isolation of BLU from goats. From our work, it is possible to isolate BLU from goats by natural infection of animals in sentinel herds and the timely collecting of blood samples from infected animals for virus isolation.

### Conclusion

Between 1986 and 1988, bluetongue virus was isolated from goats in Bayannur Meng, Inner Mongolia by cell culture, chick embryo inoculation and goat infection experiments. Group-specificity and morphological features of the isolate also confirmed the BLU identification.

### Acknowledgments

Professor Zhang Nianzu of YPIAHVS sponsored and led this project. Team members included Zhen Liying, Zhao Siying, Zhang Liying, Sun Jianqiang, Quan Hengxiang, Bao Dianjie, Li Wenxia, Zhao Weiping, Wang Yongming, Bai Long, Wang Yong (all from Bayannur Meng Veterinary Station), and Zhou Fuzhong and Zhao Kun (from YPIAHVS).

### References

- Anon. [USDA]. 1980. The riddle of bluetongue. *Agricultural Research*, 28, 4-9.
- Bowne, J.G. 1971. Bluetongue disease. *Advances in Veterinary Science and Comparative Medicine*, 15, 1-46.
- Hu Yuling, Li Gen, Li Zhihua and Zhang Khaili. 1989. Direct preparation of immunofluorescence antibody and application in diagnosis of bluetongue. *Yunnan Animal Husbandry and Veterinary Journal*, 4, 22-25.
- Hu Yuling and Peng Kegao. 1989. Analysis of local isolates of bluetongue in China by SDS-PAGE. *Yunnan Animal Husbandry and Veterinary Journal*, 4, 26-28.
- Lin Lihui and Li Zhihua. 1989. The investigation and pathogen isolation of bluetongue in Sichuan Province 1988. *Yunnan Animal Husbandry and Veterinary Medicine Journal*, 4, 57-60.
- Sellers, R.F. 1981. Bluetongue and related diseases in virus diseases of food animals. Academic Press, London, 567-584.
- Zhang Nianzu, Zhang Khaili, Li Zhihua, Hu Yuling, Li Gen, Zhao Kun, Zhou Fuzhong and Shanyu Naishun. 1989a. Application of agar gel immunodiffusion test for the diagnosis of bluetongue in animals. *Yunnan Animal Husbandry and Veterinary Medicine*, 4, 17-19.
- Zhang Nianzu, Zhang Khaili, Li Zhihua, Shanyu Naishun, Hu Yuling, Li Gen, Zhao Kun, Zhou Fuzhong and Xu Wenzhen. 1989b. Survey and studies of bluetongue in sheep. *Yunnan Animal Husbandry and Veterinary Journal*, 4, 3-12.



# Differential Epidemiology of Bluetongue Antibodies in Ruminants in China

Zhang Fuqiang\*, Li Gen\*, Peng Kegao\*, Li Xinrong\* and N.T. Hunt†

## Abstract

A total of 258 serum samples of ruminants that were positive by AGID and cELISA were tested in neutralisation tests with BLU1, BLU16 and BLU17 viruses. The samples originated from Kunming, Yiliang, Lunan, Nanpeng, Guangnan, Shizong, Luliang, Luqian and Ershan counties of Yunnan Province and Bayannur Meng of Inner Mongolia. BLU1 antibodies were found in 59 serum samples, BLU16 in 24 samples and both BLU1 and BLU16 in nine samples. No antibodies to BLU17 were detected. The results indicated that antibodies to BLU1 and BLU16 exist in Yunnan Province although antibodies to BLU1, BLU16 and BLU17 were not found in sera from Inner Mongolia. The results also indicated that other bluetongue, or cross-reacting, viruses exist in Yunnan Province.

BLUETONGUE disease is an infectious viral disease, transmitted by certain insects, that mostly affects sheep and other ruminants. Systematic study of bluetongue virus (BLU) in China started after the first outbreak in Shizong, Yunnan Province. Several BLU serotypes were isolated from Yunnan, Hubei, Sichuan, Inner Mongolia, Shandong, Shanxi, Anhui and Gansu Provinces, but the identification and distribution of the isolates still remains unknown. Work by Yunnan Tropical and Subtropical Animal Virus Diseases Laboratory on the identification of these viruses has involved cross protection tests of sheep with four BLU isolates. Micro-neutralisation test results have shown that the isolates from Yunnan, Xinjiang, and Shanxi were BLU1, from Sichuan and Hubei BLU16, and from Inner Mongolia BLU17 (Zhang Nianzu et al. 1991, 1993). This paper reports on a survey of serotype distribution in Yunnan and Inner Mongolia by means of testing for neutralising antibodies.

\* Yunnan Tropical and Subtropical Animal Virus Diseases Laboratory, Jindian 650224, Kunming, People's Republic of China.

† Department of Primary Industry and Fisheries, Berrimah Agricultural Research Centre, PO Box 79, Berrimah, Darwin, Northern Territory 0828, Australia.

## Materials and Methods

Isolates of BLU1, BLU16, BLU17, tested in previous experiments by this laboratory, were used, passaged three times in Vero cells. The isolates were used at 100 TCID<sub>50</sub>. Positive sera had previously been tested by competitive enzyme linked immunosorbent assay (cELISA) and agar gel immunodiffusion (AGID). The sera for tests were inactivated by being kept at 56°C for 30 minutes. Dilutions were made in minimum essential medium + 10% foetal calf serum. The neutralisation tests were carried out by standard methods (Gard and Kirkland 1993).

## Results

Of the total 258 samples, 59 contained BLU1 antibodies, 24 BLU16 antibodies and nine had both BLU1 and BLU16: none had BLU17 antibodies (Table 1).

## Discussion

The sera were screened by cELISA using high quality antigen and monoclonal antibodies to avoid cross-reaction with epizootic hemorrhagic disease virus (EHD) and Palyam group viruses. As no BLU17 anti-

bodies were found in any of the 258 samples, the provenance of BLU17 from Inner Mongolia was unconfirmed. Since 82 samples had antibodies to BLU1 or BLU16 or both, this suggests the existence of BLU1 and BLU16 serotypes in Yunnan Province.

**Table 1.** Distribution of neutralising antibodies to bluetongue in sera positive for group antibodies.

Source of samples	No. of samples	Serotypes of antibodies		
		BLU1	BLU16	BLU17
Lanping, Guangnan	91	26	13	0
Yuxi, Eshan	46	14	4	0
Kunming	34	1	3	0
Shizong	26	4	0	0
Yiliang	20	10	2	0
Lunan	10	4	1	0
Luliang	10	0	0	0
Luquan	7	0	0	0
Bayannur, Inner Mongolia	14	0	0	0

That there were 175 samples with no antibodies to any of these three serotypes suggests that serotypes other than these may be present in Yunnan. The possibility of multiple infections with different serotypes was confirmed, as shown by the nine samples with both BLU1 and BLU16 antibodies.

Further tests, with a wider range of reagents, should be made on the samples from Inner Mongolia. The micro-neutralisation test used in this study is recommended as the standard test for surveying and monitoring the distribution of BLU serotypes.

## References

- Gard, G.P. and Kirkland, P.D. 1993. Bluetongue virology and serology, Australian standard diagnostic techniques for animal diseases, 10-12.
- Zhang Nianzu, Zhang Khaili and Li Zihua. 1991. Cross protection test for bluetongue disease, Yunnan Animal Husbandry and Veterinary Journal, 3, 30-32.
- Zhang Nianzu, Zhang Khaili, Li Zihua, Hu Yuling, Li Gen, Peng Kegao, Wu Dexing and Li Huachun. 1993. Bluetongue in China. In: Uren, M.F. and Kay, B.H. ed., Arbovirus research in Australia, Proceedings 6th Symposium. CSIRO/Queensland Institute of Medical Research, Brisbane, 192-193.

# Bluetongue Viruses in the Asian and Southeast Asian Region

G.P. Gard\*

## *Abstract*

The first scientific accounts of the presence of bluetongue in the Asian and Southeast Asian region seem to have come from India in the 1960s. Over the next decade, reports of clinical disease in sheep and/or serology from several countries suggested that bluetongue virus activity was widespread in the area. During this period, the inaccessibility of the reference laboratory in South Africa, at Onderstepoort, meant that confirmatory assistance was not available for many countries. The detection of bluetongue virus in northern Australia in 1977 set in train a variety of activities which led to a greatly increased understanding of bluetongue in the region. Knowledge and expertise developed and reagents were prepared and made available. There was also an interest by animal health administrators and scientists in countries where sheep were farmed in unravelling the bluetongue virus and disease status of those countries. In the past ten years, various research groups have isolated and characterised bluetongue viruses in several countries in Asia and Southeast Asia. Significant serological surveys have been undertaken in many countries and entomological investigations have been initiated in a few. Many of the serotypes active are now known and there is increasing information on their biology and natural history. An additional advantage of bluetongue research activity throughout the region is that laboratory technology generally has benefited. Bluetongue has been a vehicle for introducing virological, serological and entomological laboratory and field techniques into numerous laboratories.

BLUETONGUE has been one of the most feared diseases in sheep-producing countries this century (Roberts et al. 1993). For the first half of this century, bluetongue was regarded as another 'African disease'. Then, for 30 years after the Second World War, animal health administrators regarded bluetongue as an emerging disease (Gard 1990). There were explosive outbreaks of bluetongue disease in Cyprus in 1943 and in Portugal and Spain in 1956, as well as the more insidious appearance of the disease in USA in the intervening years. Accounts of the disease in other countries soon followed. Subsequent reports from USA that the virus caused chronic infections of cattle, that semen could be a vehicle for virus transmission, and that transplacental passage was a significant feature of virus infection added to the con-

cern about bluetongue. Countries worried about the health of their national sheep flocks imposed strict quarantine to exclude the virus.

A more realistic picture of the international status of bluetongue has been gauged over the last 20 years. As countries have developed their laboratory diagnostic capacities, the presence of the bluetongue virus (BLU) has been established in most countries in tropical, subtropical and adjacent temperate zones wherever substantial populations of ruminants exist. Often the presence of bluetongue was unsuspected because the virus circulated subclinically in cattle, buffalo, goats and native sheep, species susceptible to infection but not to disease.

The recognition that bluetongue virus was present in Australia in 1977 (St. George et al. 1978) led to two decades of broad-ranging research into the virus, its vectors, epidemiology, pathogenesis and diagnosis. Realising that the Australian situation had to be considered in a regional context, Australia and several countries in Asia and Southeast Asia collabo-

---

\* Bureau of Resources Science, Department of Primary Industries and Energy, PO Box E11, Queen Victoria Terrace, Parkes, ACT 2601, Australia.

rated in research programs. Thus the bluetongue status of this part of the world is now better understood: the status in Asia and Oceania has been reviewed by Hassan (1992a) and Doyle (1992) respectively.

## Current Situation

### Australia

The presence of bluetongue was not suspected in Australia until 1977, when a virus isolated from a mixed pool of midges collected during a bovine ephemeral fever vector study was identified at Yale Arbovirus Research Unit as bluetongue (St. George et al. 1978).

This isolation of bluetongue virus initiated a long, productive research program in Australia, a country with a vital sheep industry. As a result, there is now an understanding of the viruses and vectors present in the country, and of their distribution. BLU serotypes 1, 3, 9, 15, 16, 20, 21 and 23 have been isolated in Australia and the main vectors have been shown to be *Culicoides actoni*, *C. brevitarsis*, *C. fulvus* and *C. wadai* (Gard and Melville 1989).

Bluetongue disease is the result of a complex interaction between sheep, virus and environment and does not occur naturally in Australia. The Australian vectors of BLU have a strong host preference for cattle, and small ruminants have a low antibody prevalence. Moreover, the BLU serotypes active in sheep-raising areas (strains of BLU 1 and 21) appear to be only mildly pathogenic.

### China

Bluetongue disease was first diagnosed in China in Yunnan province in 1979 (Zhang Nianzu et al. 1989). Antibody has been detected in 29 provinces, clinical disease has occurred in four (Zhang Nianzu et al. 1992) and bluetongue viruses have been isolated from sheep, goats and cattle. BLU antibodies have been detected in sheep, cattle, goats and deer (Zhang Nianzu et al. 1992). In Yunnan province more than 30 species of *Culicoides* have been found, of which four are suspected BLU vectors.

### India

The disease, ranging from isolated cases to widespread outbreaks, has been reported in India since 1963 (Mehrotra 1992). Mild to severe disease has been recorded in local and exotic breeds of sheep, but disease has not been noted in infected goats, cattle or buffalo. The virus is endemic and widely distributed. In 1973, BLU virus was isolated from experimentally infected sheep inoculated with clinical material (Uppal 1992). BLU1, 3, 4, 9, 16 and 17 have been isolated from sheep, and serological evidence sug-

gests that other serotypes also circulate in India. There is no information on the species of *Culicoides* acting as BLU vectors in India.

### Indonesia

More information on bluetongue and its vectors is known for Indonesia than for most other countries in the region. Since 1987 there has been a program to isolate BLU from sentinel cattle located at several widely separated sites in Indonesia, and BLU1, 7, 9, 12, 21 and 23 have been recovered (Sendow et al. 1992). As part of the national bluetongue research program involved the study of vectors, a considerable body of information is available. Sukarsih et al. (1992) listed 49 *Culicoides* spp. collected at six sentinel cattle sites in Indonesia. The four species proven as vectors in Australia are present and widely distributed. Other potential vectors have been trapped and identified.

### Japan

Many arboviruses are active in Japan and several have been isolated there for the first time in the world. Orbiviruses are regularly active in summer or autumn, especially in the southern cattle farming districts. The Quarterly Epidemiology Report of the Office International des Epizooties (OIE) often indicates that bluetongue viruses have been active in Japan, as evidenced by the detection of antibody, but diseased sheep have not been seen.

### Malaysia

Serological evidence of BLU presence has been recorded in Malaysia since the late 1970s (Hassan 1992b). Antibodies in imported cattle and local ruminants indicated that the virus was endemic. Clinical disease occurred in 1987 when sheep recently imported from a bluetongue-free region of southern Australia suffered dramatic disease in several states in Peninsular Malaysia and BLU 1 was isolated from one of these sheep (Chiang 1989). After the clinical disease episode in 1987, the Australian and Malaysian governments embarked on a collaborative ACIAR-sponsored bluetongue research program. Serological testing showed that multiple serotypes of BLU were endemic in the country and BLU1, 2, 3, 9, 16, and 23 were isolated from sentinel cattle and sheep (Sharifah et al. 1995).

There have been some studies on the *Culicoides* fauna of Malaysia. *Culicoides peregrinus*, *C. orientalis* and *C. shortii* are considered the most probable vectors on the basis of abundance, distribution and host preference (Cheah and Rajamanickam 1991). However, a program to recover BLU from vectors has not been attempted.

## Papua New Guinea

Serological surveys of Papua New Guinea ruminants were conducted in conjunction with testing of Australian animals soon after bluetongue was first recognised in Australia. Doyle (1992) reported that bluetongue virus occurs in Papua New Guinea, with one of the vectors being *C. brevitarsis*.

## Taiwan

Serological evidence of EHD virus infection has been reported from Taiwan (Metcalf et al. 1992). The presence of EHD on Taiwan indicates that Taiwanese ruminants could also be at risk from bluetongue.

## Thailand

Bluetongue serological surveys have been conducted recently in Thailand. Antibodies have been detected in the absence of clinical disease.

## Other countries in the region

The bluetongue status of Myanmar, Cambodia, Korea, Laos, Philippines and Vietnam are unknown, but bluetongue viruses probably circulate subclinically in all these countries.

## Discussion

Bluetongue viruses may move between countries by the transportation of viraemic vertebrates or by wind-blown infected vectors (Sellers 1992; St. George 1992). The latter mechanism is the most likely in the Asia and Southeast Asia region. Because of this regular interchange, the viruses of the region can thus be considered as forming a pool with some commonalities, with the extent of the mixing depending on geography and predominant wind patterns. Conventional quarantine measures cannot prevent infected vectors crossing national borders. There is no evidence that bluetongue has become established through the international trade of live ruminants or their germplasm.

Conversely, bluetongue viruses within the region can be differentiated by topotyping techniques (Gould et al. 1992), reflecting uncommon genetic sequences due to a lack of mixing. Whether there are any correlations between topotype and other biological characteristics is as yet unknown.

An increasing number of countries in the southern and eastern Asian and Pacific region are gathering information on their bluetongue status. One anticipates that, as more data are accumulated, the widespread distribution of bluetongue in all populations of susceptible ruminants will be increasingly accepted by animal health administrators. Decision makers

will need to understand the factors contributing to virus virulence and to disease susceptibility of sheep.

## References

- Cheah, T.S. and Rajamanickam, C. 1991. Occurrence of *Culicoides* spp. in sheep sheds and their relevance to bluetongue in Peninsular Malaysia. *Tropical Animal Health and Production*, 23, 63–65.
- Chiang, B.L. 1989. An outbreak of bluetongue in imported sheep. Proceedings 1st Congress, Veterinary Association of Malaysia, 49–52.
- Doyle, K.A. 1992. An overview and perspective on orbivirus disease prevalence and occurrence of vectors in Australia and Oceania. In: Walton, T.E. and Osburn, B.I., ed., *Bluetongue, African horse sickness and related orbiviruses*. Proceedings 2nd International Symposium. CRC Press, Boca Raton, 44–57.
- Gard, G.P. 1990. Akabane and bluetongue. In: University of Sydney, Post Graduate Committee in Veterinary Science, *Sheep medicine*, Proceedings, 141, 321–330.
- Gard, G.P. and Melville, L.F. 1989. The evolution of bluetongue in northern Australia. In: Uren, M.F., Blok, J. and Manderson, L.H. ed., *Arbovirus research in Australia*. Proceedings 5th Symposium. CSIRO/Queensland Institute of Medical Research, Brisbane, 303–305.
- Gould, A.R., McColl, K.A. and Pritchard, L.I. 1992. Phylogenetic relationships between bluetongue viruses and other orbiviruses. In: Walton, T.E. and Osburn, B.I., ed., *Bluetongue, African horse sickness and related orbiviruses*. Proceedings 2nd International Symposium. CRC Press, Boca Raton, 452–460.
- Hassan, A. 1992a. Status of bluetongue in the Middle East and Asia. In: Walton, T.E. and Osburn, B.I., ed., *Bluetongue, African horse sickness and related orbiviruses*. Proceedings 2nd International Symposium. CRC Press, Boca Raton, 38–41.
- 1992b. Epidemiology of bluetongue virus infection in Malaysia. In: Walton, T.E. and Osburn, B.I. ed., *Bluetongue, African horse sickness and related orbiviruses*. Proceedings 2nd International Symposium. CRC Press, Boca Raton, 155–161.
- Mehrotra, M.L. 1992. Studies on bluetongue in India: Distribution and isolation of viruses. In: Walton, T.E. and Osburn, B.I. ed., *Bluetongue, African horse sickness and related orbiviruses*. Proceedings 2nd International Symposium. CRC Press, Boca Raton, 181–187.
- Metcalf, H.E., Luedke, A.J. and Jochim, M.M. 1992. Epizootic hemorrhagic disease virus infection in cattle. In: Walton, T.E. and Osburn, B.I. ed., *Bluetongue, African horse sickness and related orbiviruses*. Proceedings 2nd International Symposium. CRC Press, Boca Raton, 222–237.
- Roberts, D.H., Lucas, M.H. and Bell, R.A. 1993. Animal and animal product importation and the assessment of risk from bluetongue and other ruminant orbiviruses. *British Veterinary Journal*, 149, 87–99.
- Sellers, R.F. 1992. Weather, *Culicoides*, and the distribution and spread of bluetongue and African horse sickness viruses. In: Walton, T.E. and Osburn, B.I. ed., *Bluetongue, African horse sickness and related orbiviruses*.

- Proceedings 2nd International Symposium. CRC Press, Boca Raton, 284–290.
- Sendow, I., Soleha, E., Daniels, P.W. and Sukarsih 1992. Bluetongue viruses in Indonesia. In: Uren, M.F. and Kay, B.H. ed., Arbovirus research in Australia. Proceedings 6th Symposium. CSIRO/Queensland Institute of Medical Research, Brisbane, 194–196.
- Sharifah, S.H., Ali, M.A., Gard, G.P. and Polkinghorne, I.G. 1995. Isolation of multiple serotypes of bluetongue virus from sentinel livestock in Malaysia. *Tropical Animal Health and Production*, 27, 37–42.
- St. George, T.D. 1992. Occupation of an ecological niche in Pacific Ocean countries by bluetongue and related viruses. In: Walton, T.E. and Osburn, B.I. ed., Bluetongue, African horse sickness and related orbiviruses, Proceedings 2nd International Symposium. CRC Press, Boca Raton, 76–84.
- St. George, T.D., Standfast, H.A., Cybinski, D.H., Dyce, A.L., Muller, M.J., Doherty, R.L., Carley, J.G., Filippich, C. and Frazier, C.L. 1978. The isolation of a bluetongue virus from *Culicoides* in the Northern Territory of Australia. *Australian Veterinary Journal*, 44, 153–154.
- Sukarsih, Daniels, P.W., Sendow, I. and Soleha, E. 1992. Longitudinal studies of *Culicoides* associated with livestock in Indonesia. In: Uren, M.F. and Kay, B.H. ed., Arbovirus research in Australia, Proceedings 6th Symposium. CSIRO/Queensland Institute of Medical Research, Brisbane, 203–209.
- Uppal, P.K. 1992. Present position of African horse sickness and bluetongue in India. In: Walton, T.E. and Osburn, B.I. ed., Bluetongue, African horse sickness and related orbiviruses, Proceedings 2nd International Symposium. CRC Press, Boca Raton, 175–180.
- Zhang Nianzu, Zhang Khaili, Li Zihua, Hu Yuling, Li Gen, Peng Kegao, Wu Dexing and Li Huachun. 1992. Bluetongue in China. In: Uren, M.F. and Kay, B.H. ed., Arbovirus research in Australia. Proceedings 6th Symposium. CSIRO/Queensland Institute of Medical Research, Brisbane, 192–193.
- Zhang Nianzu, Zhang Khaili, Li Zihua, Shanyu Naishun, Hu Yuling, Li Gen, Zhao Kun, Zhou Fuzhong and Xu Wenzhen. 1989. Investigation and study of bluetongue disease of sheep in Yunnan, China. *Yunnan Animal Husbandry and Veterinary Journal*, 4, 3–12.

# A Strain of Virus Isolated from *Culicoides homotomus*

Li Xiaocheng\*, Wu Shiyun\*, Cheng Yanxia\*, Cheng Zhongguo†, Meng Guangxiao†, Zhou Weihai§ and Su Genyuan§

## Abstract

A strain of RNA virus was isolated from *Culicoides homotomus*. The virus was spherical, unenveloped, 25–30 nm in diameter and produced at least six bands in RNA-electrophoresis gels. The virus produced cytopathic effects (CPE) in C6/36, Vero, BHK21, pharynx/larynx and chick-embryo fibroblast tissue cultures. It had an optimum growth temperature of 37°C, and was resistant to chloroform and ether, but sensitive to 0.25% and 0.5% trypsin. When injected into cattle and goats the virus produced homologous antibodies but no clinical signs. However, sheep developed fever when infected intravenously. The virus was re-isolated. After 12 passages, the virus could infect one- to two-day-old mice with classical signs and 80% mortality. The virus has not yet been identified.

---

\* Animal Quarantine Institute, Ministry of Agriculture, Qingdao 266032, People's Republic of China.

† Animal and Plant Quarantine Bureau, Qingdao 255011, People's Republic of China.

§ Anhui Provincial Veterinary Epidemic Prevention Station, Hefei, People's Republic of China.

# **Aetiological and Epidemiological Studies on Ibaraki Disease in Taiwan**

**Lu Yongsiu, Li Yungkung and Liou Pepper\***

## *Abstract*

Nonsuppurative encephalitis has been reported sporadically in Taiwan since 1985. However, not until July 1990 was the causative agent recognised, when Ibaraki disease virus was first isolated from the cerebellum of a cow with non-suppurative encephalitis in the Chia-Yi district of Taiwan. During the period of the disease, an epidemiological survey was conducted on 163 young calves, aged less than one year, from 20 farms located in four towns in the Chia-Yi district. The results showed that 13 calves (7.9%) had suffered from the disease. Twelve sick calves were culled or died within a few days of the onset of clinical signs. Virus isolation was performed on blood samples from 73 calves. Overall, 28 strains of orbiviruses were isolated from plasma and 11 strains from blood cells. From September to October, six virus strains were isolated from the nasal discharges or blood of infected cattle, with symptoms mainly in the respiratory tract, from two farms in Pingtung. Viruses isolated from field cases were pathogenic to suckling mice, while experimental virus infections of cattle induced respiratory tract lesions. Virus was still recoverable from the blood of infected cattle 45 days after challenge. Over four consecutive years (1987–1990) a serological survey was carried out for antibodies to Ibaraki disease in cattle in Taiwan. The antibody-positive rate of dairy cattle in Taiwan increased from 25% in 1987 to 90% in 1990. These results indicate that the disease was epidemic in Taiwan's cattle population. This is the first report in Taiwan, and the third report (after Japan and Korea) in the world on clinical cases and virus isolation of Ibaraki disease in cattle.

---

\* Taiwan Provincial Research Institute for Animal Health,  
376 Zhongzheng Road, Freshwater Town, Taiwan 251.



# Epidemiological and Aetiological Studies on Chuzan Disease in Taiwan

Lu Yongsiu, Li Yungkung and Liou Pepper\*

## *Abstract*

Since 1985, many cases of nonsuppurative encephalitis and congenital abnormalities, of unknown aetiology, have occurred in cattle herds in Taiwan. In 1989, a serological survey was conducted in Taiwan on the prevalence of antibody to Chuzan disease. The antibody positive rate was 47%. A second survey in 1990 found the positive rate had increased to 84%. From December 1991 to October 1992, 26 calves with nervous signs and lameness were observed in dairy farms located in Tainan and Kaohsiung districts: 22 calves died within a few days of the onset of severe clinical signs. Virus isolation was attempted using heparinised blood samples collected from 12 sick calves. Three strains of virus were isolated. Using serological, biological, physical, and electron microscopical studies, these were identified as being Chuzan virus of the genus *Orbivirus*. Chuzan virus was first reported in Japan in 1985, where it caused an epidemic of congenital abnormalities with hydranencephaly/cerebellar hypoplasia syndrome of calves. This is the first report of Chuzan disease with the isolation of the Chuzan virus in Taiwan, and only the second report in the world.

---

\* Taiwan Provincial Research Institute for Animal Health,  
376 Zhongzheng Road, Freshwater Town, Taiwan 251.

# Sentinel Herds

# Introduction

THE study of bluetongue epidemiology presents some unique difficulties. Overt disease affects only a small percentage of the vertebrate hosts of bluetongue virus. Many silent infections occur in cattle, buffalo, deer, antelope, goats and some breeds of sheep. These silent infections explain why bluetongue viruses, even when their presence is not perceived, are readily accessible for transmission by *Culicoides* vector species.

Another difficulty, referred to many times in these Proceedings, is that the disease is caused by at least 24 distinguishable viruses which form a related group with complex interrelationships. If all 24 bluetongue virus serotypes are available to a laboratory, it is simply a matter of routine to carry out 24 separate tests on serum samples collected in random surveys. Sera positive in the screening tests can then be titrated. But this all requires significant staff effort and expense. Sometimes this approach does give a clear answer, if just a single serotype is endemic in a particular area. More often, however, the presence of several cross-reacting serotypes means that a sophisticated mathematical analysis must be applied to assess the probabilities of individual serotypes being involved.

Silent infections with bluetongue viruses are readily detectable in endemic areas by taking regular and serial blood samples from healthy cattle, buffalo, goats or sheep, and then culturing for bluetongue viruses and testing for antibodies. Once the full range of bluetongue viruses that circulate in an area has been isolated from sentinel animals, retrospective and real time serological studies can unravel existing epidemiology and detect any appearance of additional serotypes on a real time basis. The outcome is a regularly updated guide as to which vaccines are necessary for protection of sheep in a given region. Virus-containing blood from healthy sentinel animals has been shown often to be fully virulent to sheep and so is valuable to validate experimental vaccines.

The sentinel herd technique that evolved in Australia has been successfully applied in Indonesia, Malaysia and in various provinces of China. Information on seasonality has yielded some unique observations in Inner Mongolia. With our emerging knowledge about the serotypes, it is time to coordinate research in the Asian-Pacific region, and to encourage countries that are not yet participating to define their bluetongue situation by establishing sentinel herds on a regional basis.

# Australian National Arbovirus Monitoring Program—a Model for Studying Bluetongue Epidemiology in China

P.D. Kirkland\*, T. Ellis†, L.F. Melville§, and S.J. Johnson¶

## Abstract

In Australia bluetongue viruses have not caused outbreaks of disease in sheep, but their presence continues to cause economic loss, especially in terms of reduced markets for the export of live sheep, cattle, semen and embryos. As some of the Australian serotypes of bluetongue virus (BLU) are capable of causing disease under experimental conditions, the sheep industry and animal health authorities are concerned that pathogenic BLU serotypes could enter major sheep-raising areas. This paper describes an extensive, nationwide sentinel herd program to monitor BLU epidemiology in Australia. This National Arbovirus Monitoring Program ensures the detection of any movements of bluetongue viruses towards the disease-free zone of southern and eastern Australia, and allows delimitation of virus-free zones from which animals can be safely exported. To assist with the development of disease control programs, a similar approach could be used to monitor the spread of bluetongue and other important vector-borne viruses in China and other countries.

AUSTRALIA'S international position as a supplier of live cattle, sheep and goats, and of ruminant germplasm, has been heavily dependent on the freedom of its national flocks and herds from major infectious diseases. Thus there was great concern about the threat to the livestock trade when, in 1977, a virus belonging to the bluetongue group was identified in Australia. Studies from 1978 to 1986 revealed the presence of another seven bluetongue virus (BLU) serotypes. The history of these virus isolations, and an overview of the epidemiology of bluetongue viruses in Australia, have been described previously (Gard et al. 1988; Gard and Melville 1989; Ward

1994). Detailed studies have also identified the biology and response to climatic variations of the major Australian BLU vectors.

Australia, like China, has large areas where there are sheep and few cattle. Australia's sheep are located mainly in the southern and interior parts of the country where there are no BLU vectors. Large desert areas separate the major sheep-raising zones from the northern vector populations. As well as the cold climate in the south and dry climate in the inland, these sheep-raising zones are also protected by oceans to the south, east and west. Consequently there are only relatively narrow pathways for the movement of vectors and their viruses into the sheep populations. Bluetongue virus infections have been largely confined to cattle and buffalo, mainly because there is no overlap in distribution between *Culicoides brevitarsis*, the major vector, and significant sheep populations. Climatic conditions restrict this vector to the northern parts of the country and to a narrow strip along the northern and central coastal regions of Queensland and New South Wales. In these latter areas, a few sheep have been infected but shown no evidence of disease. Nevertheless, the presence of these viruses in Australia continues to cause economic loss, especially in terms of reduced markets

\* Virology Laboratory, Elizabeth MacArthur Agricultural Institute, PMB 8, Camden, New South Wales 2570, Australia.

† Department of Agriculture, South Perth, Western Australia, Australia.

§ Department of Primary Industry and Fisheries, Berrimah Agricultural Research Centre, PO Box 79, Berrimah, Darwin, Northern Territory 0828, Australia.

¶ Queensland Department of Primary Industries, Oonoonba Veterinary Laboratory, PO Box 1085, Townsville, Queensland 4810, Australia.

for the export of live sheep, cattle, semen and embryos.

As some of the Australian BLU serotypes are capable of causing disease under experimental conditions, the sheep industry and animal health authorities are concerned that pathogenic BLU serotypes could enter major sheep-raising areas. This threat is only likely under extremely favourable conditions for the vector, such as periods of high rainfall and mild autumn temperatures.

This paper reviews BLU epidemiology in Australia and describes a nationwide sentinel herd monitoring the spread of bluetongue and other important vector-borne viruses. A similar approach could be followed in China and other countries to monitor the spread of bluetongue and other important vector-borne viruses, thus helping the development of control programs and the identification of livestock populations free of arbovirus infections.

## Materials and Methods

The objectives of this program were to:

- determine the annual distribution of BLU serotypes currently in Australia to provide an early warning of the movement of potentially pathogenic viruses southwards towards major sheep populations
- monitor any introduction of new BLU serotypes into northern Australia
- define regions free of bluetongue and Akabane virus infections to assist the export of livestock.

From 1984 to 1992, bluetongue infections in Australia were monitored by serology and virology studies in sentinel cattle. These studies were usually conducted and funded by State or Territory Departments of Agriculture or Primary Industries, with additional funds from farmers through the Meat or Wool Research Corporations. There were differences in the frequency and intensity of monitoring and, at times, significant gaps among the areas being covered.

In 1993, an integrated national program was established to monitor the spread of economically important insect-borne livestock viruses and their vectors. This new program is jointly funded by the livestock industries (the farmers) and the State and Federal (Australian) governments.

The National Arbovirus Monitoring Program (NAMP) is effected through the regular collection of blood samples from young cattle in sentinel herds and by the collection of insects with light traps. Most virus transmission shows a distinct seasonal pattern, occurring in summer and autumn and ended by the onset of winter in the temperate regions. Each year, therefore, the NAMP begins in the Southern Hemisphere spring (between August and October) and

concludes at the end of autumn in the following calendar year.

In 1993-94, there were 62 insect collection sites and sentinel herds located throughout the distribution area of *Culicoides brevitarsis*, the main vector, and in the vector-free areas of the Australian mainland and Tasmania (Fig. 1). Light traps for insect collections are operated for three nights each month, and in most locations for eight months of the year, although some locations in the tropics are sampled all year round. Insects are collected into alcohol and the *Culicoides* species identified by entomologists in government laboratories in Western Australia, the Northern Territory, Queensland and New South Wales (NSW).

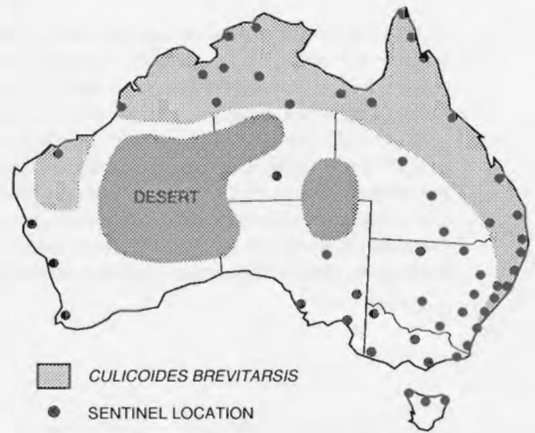

Figure 1. Location of sentinel herds and vector monitoring sites for National Arbovirus Monitoring Program (NAMP).

At the sentinel herd sites, a minimum of ten young cattle, usually five to seven months old, are bled once monthly for eight months of the year, beginning at the likely start of the vector season. Year round sampling, at monthly intervals, occurs at several tropical sites. At the Coastal Plains Research Station near Darwin in the Northern Territory, where most of the new BLU serotypes have been first isolated, a group of 20 sentinel animals are bled weekly for six months during the peak vector season. In vector-free areas, animals are sampled at the start and finish of each summer-autumn period.

Serum samples from sentinel animals are tested for BLU antibodies by competitive enzyme linked immunosorbent assay (cELISA) and, if positive, by virus neutralisation (VN) tests. Antibodies to Akabane and bovine ephemeral fever viruses are detected by VN.

Virus isolation is undertaken routinely on heparinised blood samples from the Coastal Plains sentinel herd near Darwin, Northern Territory, from

the time of the first bluetongue infections each season. For virus isolation, specimens are initially inoculated intravenously into 10-11-day-old chicken embryos. After seven days, the embryo homogenates are passaged onto mosquito cell cultures (*Aedes albopictus* C6/36) and then passaged up to three times onto BHK21 cells to detect any cytopathology due to virus replication.

## Results

Between 1987 and 1993, most bluetongue surveillance in Western Australia comprised structured serological surveys in which single serum samples were collected. These surveys confirmed the presence of BLU serotypes 1 and 21 in known vector areas and freedom from infection in vector-free regions. In Queensland, similar surveys occurred until 1990, when sentinel herds were established. This monitoring showed that infection of cattle with BLU1 and 21 was relatively common in central and northern Queensland. Small numbers of sheep also appeared to be infected with BLU1 but there was no evidence of disease (Flanagan et al. 1993).

In New South Wales and the Northern Territory, sentinel animals were sampled in a similar distribution to that described above for the 1993/4 NAMP, but the number of sites and sampling frequency varied. In 1988, bluetongue infection was identified in sentinel cattle in the North Coast region of NSW. In 1989, infection was widespread along the coastal strip from north to south as far as Bodalla and inland through the Hunter Valley region on the Central coast. Significant numbers of sheep in very small flocks were infected in the Hunter and Manning River Regions but showed no evidence of disease. In both years, the transmitted virus was BLU1.

In the Northern Territory, bluetongue virus infection has been found in sentinel cattle each year except 1990. The level of activity and number of serotypes transmitted has varied from year to year. In 1987, only BLU3 was identified, with BLU1 and 16 in 1988, and BLU1, 3 and 23 in 1989. In 1991, only BLU3 was identified, while in 1992 animals were infected with BLU16 and 20. This latter was the first occasion on which BLU20 had been isolated and identified since the original isolation of bluetongue virus in 1975 (St. George et al. 1978), suggesting that this serotype may have died out in Australia in the interim and subsequently re-entered the country.

During the 1993/4 arbovirus year, the transmission patterns of the three arboviruses of interest to the NAMP were identified as follows.

### Bluetongue viruses

There was evidence of BLU transmission in four states; Western Australia, Northern Territory, Queen-

sland and NSW. Although transmission occurred over a large geographical area, infection was still confined to known vector areas (Fig. 2).

In the Northern Territory, BLU seroconversions were only recorded in the sentinel herds at Berrimah and Coastal Plains, both near Darwin. Transmission occurred between January and March 1994. Only BLU1 appeared active: there was no detectable transmission of other serotypes, including no evidence of the introduction of new serotypes.

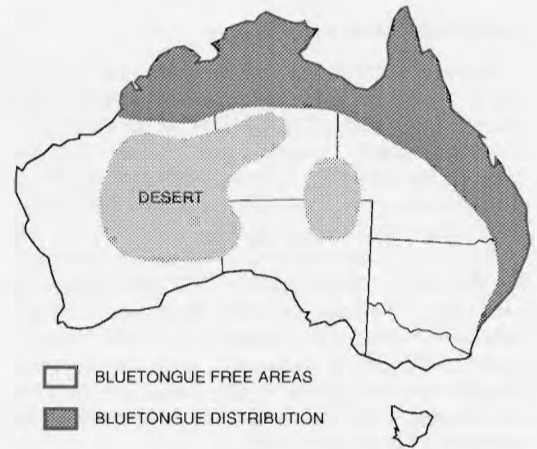

Figure 2. Distribution of bluetongue viruses and bluetongue-free zones in Australia, 1994.

In the north-west of Western Australia, at Kununurra, seroconversions occurred each month between November 1993 and January 1994 inclusive. At Kalumburu, seroconversions occurred in August 1993 and April 1994. Only BLU1 was being spread in Western Australia. The southern vector-free regions of Western Australia were free of bluetongue virus infection.

In Queensland, seroconversions were recorded in October 1993 at Etna Creek (near Rockhampton) and between November 1993 and April 1994 in herds in the far north and on Cape York. In southern Queensland, seroconversions occurred at Dalby and Maryborough in April. There was evidence of infection with BLU21 in the herds on Cape York and Northern Queensland at Utchee Creek, although there was also infection with BLU1 at Utchee Creek and among the herds in Southern Queensland. These are all areas where there are very few sheep.

In NSW, bluetongue transmission appeared to spread from a focus on the mid-north coast at Coffs Harbour in December 1993, moving mainly southwards, and eventually reaching Camden, where seroconversions were recorded in early June, consistent with infection during May. Infection was first recorded on the NSW far-north coast in June, with a

low level of infection at Lismore. Herds on the mid-north Coast and in the coastal Hunter–Manning regions showed high rates (60–100%) of seroconversion. Infection, shown to be caused by BLU1, spread west as far as Scone on the Upper Hunter Valley. At the end of the season, bluetongue antibody was present in some 63% (14/22) of sentinel sheep at Gloucester, although there were no reports of disease. The prevalence of Akabane antibody in these sheep was more than 95% (21/22), confirming a high attack rate from *Culicoides* spp.

### **Bovine ephemeral fever virus**

Bovine ephemeral fever virus (BEF) has a largely similar pattern of distribution to bluetongue virus. There is a reservoir of infection in the northern areas and the mosquito vectors move the virus into the south in the summer. Although the main vector is probably a mosquito, this virus is usually confined to areas where bluetongue and Akabane viruses are found, that is, areas where *C. brevitarsis* is common. In 1994, there was evidence of BEF transmission in four states; Western Australia, Northern Territory, Queensland and NSW. However, in NSW, where a mosquito vector is suspected, infection occurred beyond the usual limits of the *Culicoides* endemic area. Significant disease occurrence was noted in the Northern Territory and NSW.

In the Northern Territory, BEF infection was detected in all northern herds with infection likely between January and March 1994. The sentinel herd at Alice Springs, near the centre of Australia, remained free of infection. In Western Australia, in the far north-west at Kalumburu, BEF seroconversions were recorded in August and October 1993.

In Queensland, sentinels were infected in the Gulf of Carpentaria and Cape York at various times between December 1993 and May 1994. At Utchee Creek BEF transmission occurred in January. In south-east Queensland transmission occurred at a low level between January and April 1993.

In NSW there was extensive BEF transmission, commencing in the Hunter–Manning region on the coast in the middle of the state and on the far-north coast. The disease was particularly severe at Paterson in the Hunter Valley, with 9/10 sentinels very sick and all seroconverting within one month. The other notable feature was the spread up the Hunter Valley beyond Scone and to Dubbo, about 400 km inland.

### **Akabane virus**

There was generally a lower level of Akabane infection than usual, and less than the other viruses being investigated. In Western Australia the herd at Kalumburu showed evidence of Akabane infection in August and October 1993, while in the Northern Territory seroconversions occurred in three herds

between January and March 1994. In Queensland sporadic infections occurred in most locations between December 1993 to February 1994 and April to May 1994. Infections were detected between February and June 1994 in the northern coastal herds in NSW, with transmission occurring as far south as Camden. All Akabane virus transmission occurred within the arbovirus endemic area, that is, within the range of the principal vector *C. brevitarsis*. The inland and southern areas of NSW and all southern states remained free of infection.

## **Discussion**

In Australia, there is continuing economic loss because of the presence of several arboviruses which infect livestock. Akabane and bluetongue viruses, because of their potential to cause disease outbreaks and because of the continuing disruptions to trade, are of concern to the cattle, sheep and goat industries.

In the case of sheep, a significant feature affecting the complex interaction between these viruses and their mammalian hosts is the significant separation between the national sheep flock and relevant vector populations. Although disease caused by Akabane virus has occurred in sheep in NSW, only relatively small numbers of sheep live within the vector zone with virtually none at the critical stage of gestation (during which viral infection causes teratogenic effects) during the vector season. However, each year, Australian access to valuable export markets for the sale of live cattle and sheep, and embryos and semen, is denied because of the presence of Akabane virus in the country.

Although there have been cases of sheep being naturally infected with bluetongue virus in small flocks in New South Wales and Queensland, these have not been near the principal sheep areas, nor has there been any disease. The NAMP results for 1993/94 confirm that BLU serotypes with pathogenic potential appear still to be confined to a discrete area in the Northern Territory, extremely remote from the commercial sheep areas, and there is no evidence of the entry of new BLU serotypes. Unless a more pathogenic strain of virus were to be transmitted in the temperate zones of either eastern or western Australia, the risk of an outbreak of bluetongue disease appears to be low. Nevertheless, as with the Akabane situation, disruptions to trade continue.

However, the NAMP is able clearly to define the limits of both these important arboviruses and their vectors, and to identify distinct seasonal patterns of transmission. As a consequence of establishing both patterns and times of transmission, it is possible to identify the sheep populations most at risk of disease if a pathogenic virus were to spread southwards

(although the latter has not happened so far). As a corollary to the above, it is possible to certify, with reliability, geographical areas that are continually free from bluetongue and Akabane viruses and vector activity, and to define the times at which there is no risk of infection in areas where there is seasonal arbovirus transmission. These patterns of virus and vector spread, especially along the key southern interface with major sheep and cattle populations, have been developed from information gathered in intensive studies over more than 20 years. The vector- and virus-free areas can therefore be described very accurately, and export shipments of either livestock or germplasm can be made from these areas with a high degree of confidence. Large populations of livestock (more than 30 million sheep) previously described as being located within a vector area have now been shown conclusively to be free of arbovirus infections: these populations should now be eligible for inclusion in export shipments.

When individual sentinel herds are sampled, useful information can be obtained about the epidemiology of vector-borne viruses, such as bluetongue and Akabane, on a local basis. However, samples obtained from a regional, or preferably nationwide, network of coordinated sentinel herds provide much more valuable data. Such a system is recommended for a country where the epidemiology of an arbovirus disease has not been studied in detail. In China, for example, understanding the movements of viruses such as bluetongue may provide a guide to the times and places when a disease outbreak will occur, and may allow identification of serotypes of greatest threat. In turn, this may allow initiation of a strategic, preventative vaccination program to control disease in the most economical and efficient manner. In areas where there may be a restricted number of serotypes, the need for vaccines against only one or two sero-

types can be predicted. Efforts to establish regional and national networks of sentinel herds should therefore be encouraged actively.

## Acknowledgments

Many farmers throughout Australia have given outstanding co-operation for nearly 20 years, which has been essential for the success of the monitoring studies. Funding has been provided by all state governments, the Australian federal government, Australian Meat Research Corporation and Australian Wool Corporation.

## References

- Flanagan, M., Dashorst, M.E., Ward, M.P., Morris, C.M. and Johnson, S.J. 1993. The current bluetongue situation in Queensland. In: Uren, M.F. and Kay, B.H. ed., Arbovirus Research in Australia, Proceedings 6th Symposium. CSIRO/Queensland Institute of Medical Research, Brisbane, 188–191.
- Gard, G.P. and Melville, L.F. 1989. The evolution of bluetongue in northern Australia. In: Uren, M.F. and Kay, B.H. ed., Arbovirus Research in Australia, Proceedings 6th Symposium. CSIRO/Queensland Institute of Medical Research, Brisbane, 303–305.
- Gard, G.P., Shorthose, J.E., Weir, R.P., Walsh, S.J. and Melville, L.F. 1988. Arboviruses recovered from sentinel livestock in northern Australia. *Veterinary Microbiology*, 18, 109–118.
- St. George, T.D., Standfast, H.A., Cybinski, D.H., Dyce, A.L., Muller, M.J., Doherty, R.L., Carley, J.G., Filippich, C., and Frazier, C.L. 1978. The isolation of a bluetongue virus from *Culicoides* collected in the Northern Territory of Australia. *Australian Veterinary Journal*, 54, 153–154.
- Ward, M.P. 1994. Epidemiology of bluetongue in Australia. *Australian Veterinary Journal*, 71, 3–7.



# Recent Experiences with the Monitoring of Sentinel Herds in Northern Australia

L.F. Melville\*, R. Weir\*, M. Harmsen\*, S. Walsh\*, N.T. Hunt\*, I. Pritchard<sup>†</sup> and P.W. Daniels<sup>†</sup>

## Abstract

From 1990 to 1995, sentinel herds have been monitored regularly at six locations throughout the Northern Territory of Australia. At all sites, monthly serology has been conducted for the bluetongue (BLU), epizootic hemorrhagic disease (EHD) and Palyam group viruses. Weekly virus isolation was also carried out at the site of greatest known arboviral activity. During the observation period, five BLU serotypes, five EHD serotypes, three Simbu serogroup viruses, one bovine ephemeral fever (BEF) serogroup virus and other arboviruses were isolated from the sentinel cattle. There was marked annual variation in the total number and identity of viruses isolated. Seroconversions in the sentinel herds also showed annual variation.

THE isolated bluetongue viruses have been studied molecularly: cDNA was prepared from isolates of each serotype of each year, and a fragment from the genome segment RNA3 was amplified by PCR. Nucleotides of these fragments have been sequenced and the sequences compared with the prototype Australian strain for each serotype. While for most isolates there was little variation from known sequences, in the case of recent isolates of BLU20 and 21 there were differences greater than 5%, indicating strains of viruses not encountered previously.

A bluetongue virus (BLU), serotype 20, was first isolated from *Culicoides* collected in the Northern Territory of Australia in 1975 (St. George et al. 1978). In the eleven years to 1986, a further seven serotypes were isolated (Gard et al. 1988). Since then no other serotypes have been isolated, although various combinations of the previously identified serotypes have been isolated in most years (Gard and Melville 1992). Currently eight serotypes have been identified, BLU1, 3, 9, 15, 16, 20, 21 and 23.

The first BLU isolation came from insects, *Culicoides* species., which were being collected in conjunction with serological monitoring of a sentinel herd of cattle. The discovery of a bluetongue virus resulted in intensification of the sentinel program, and the BLU serotypes subsequently identified were isolated from sentinel cattle (St. George et al. 1980; Gard et al. 1988). Since 1990, the sentinel herd program for arbovirology has been part of the Northern Australian Quarantine Strategy (NAQS), and in 1994 the NAQS arbovirology program was incorporated into the National Arbovirus Monitoring Program (NAMP). This paper reports the results of sentinel herd monitoring in the Northern Territory from 1990 to 1995, primarily conducted as a component of NAQS, but supplemented by other programs for the characterisation of isolates.

## The Sentinel Program

The sentinel program has had three primary objectives:

- isolation of arboviruses, particularly bluetongue viruses, that are active each year;
- serological monitoring of the annual distribution of major arboviruses; and
- serological monitoring of seasonal patterns of infections.

\* Department of Primary Industry and Fisheries, Berrimah Agricultural Research Centre, PO Box 79, Berrimah, Darwin, Northern Territory 0828, Australia.

<sup>†</sup> CSIRO Animal Health Laboratory, PO Bag 24, Geelong 3220, Australia.

## Virus isolation of arboviruses

The Coastal Plains Research Station (Fig. 1), site of the initial isolation of a BLU virus and most subsequent isolations, has been chosen as the sampling site representative of northern Australia. Past experience has shown that a greater range of viruses can be isolated here than at the other Northern Territory sites sampled to date. Monitoring occurs to detect arboviruses new to Australia, and to identify which of the known viruses are circulating each year at the sentinel site.

## Serological monitoring of annual distribution of major arboviruses

There are also sites at locations representative of large pastoral areas or of other places important to the livestock industries (Fig. 1). Thus a site at the Berrimah Agricultural Research Centre is important: as other BLU research is conducted there it is essential to monitor its background arbovirus activity. In addition, Berrimah Agricultural Research Centre is adjacent to the port of Darwin, through which livestock are exported. Sites at the Douglas Daly Research Farm, Katherine Research Station and Victoria River Research Station monitor for the distribution of viruses to the south, south-east and south-west respectively. At various times, sites further to the south-east have been monitored for the spread of bluetongue viruses beyond their normal range (Newcastle Waters, Macarthur River and Rockhampton Downs, which is the current site). The Arid Zone Research Institute in the far south of the Northern Territory monitors an area usually free of arboviruses.

## Serological monitoring of seasonal patterns of infections

All sites have been sampled monthly for serology, to determine not only the distribution of infections each year, but also the seasonal pattern of those infections. Knowledge of seasonal patterns is important epidemiologically to aid an understanding of the conditions under which the risk of spread increases. Similarities and differences among the sentinel sites, and among the patterns of distribution of the viral groups, can also be identified.

## Sampling protocols

Samples of heparinised blood for virus isolation have been collected weekly at Coastal Plains Research Station. Sera samples for serology have been collected monthly from most sites, although some sites in the far south and south-east may be sampled only every three months, to reduce costs.

## Test procedures

Samples for virus isolation were processed through embryonated chicken eggs, mosquito cell (C6/36)

cultures and mammalian cell cultures (Gard et al. 1988). Sera were tested by agar gel immunodiffusion (AGID) for antibodies to the bluetongue, Simbu (Akabane, AKA), bovine ephemeral fever (BEF), epizootic hemorrhagic disease (EHD) and Palyam groups of viruses. In recent years, use of the more specific competitive enzyme linked immunosorbent assay (cELISA) for BLU group antibodies (Lunt et al. 1988) has replaced AGID testing for that serogroup. Microtitre serum neutralisation tests have been used when more serotype-specific information has been required for any of the viruses.

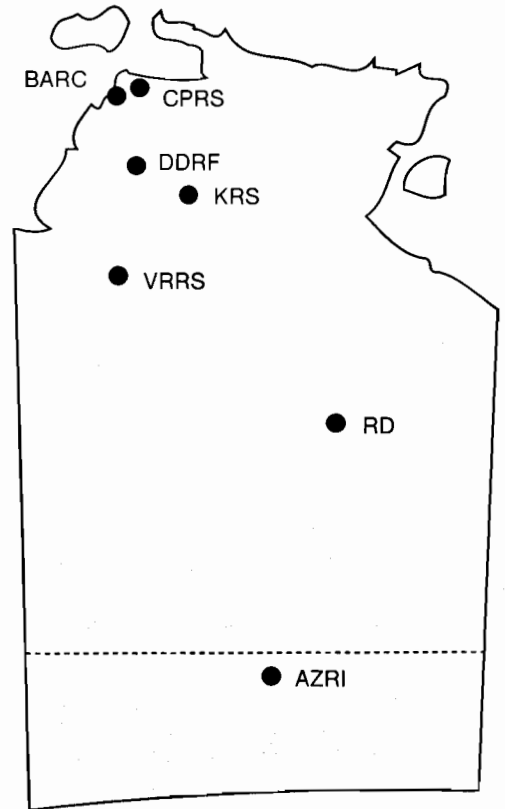

Figure 1. Sites of sentinel cattle herds monitored for arbovirology in the Northern Territory: BARC, Berrimah Agricultural Research Centre; CPRS, Coastal Plains Research Centre; KRS, Katherine Research Station; VRRS, Victoria River Research Station; RD, Rockhampton Downs; AZRI, Arid Zone Research Institute.

## Molecular epidemiology

Recently, comparisons among isolates based on genotype have introduced an extra dimension to sentinel studies. A specific fragment of BLU viral RNA segment 3 has been amplified in polymerase chain

reactions (PCR) (Saiki et al. 1988), using primers described by McColl and Gould (1994). The nucleotide sequence of the amplified products has been determined by dideoxynucleotide chain termination sequencing (Sanger et al. 1977).

Nucleotide sequence alignments were carried out using the ALIGN Plus Program Version 2.0 (Scientific & Educational Software). SEQPROG (Knowles, unpublished) was used to compare the sequences using DNADIST and KITSCH programs from the PHYLIP package (Felsenstein 1985) and to give a single most parsimonious, unrooted tree. Basically, isolates were assigned to groups on the basis of aligned sequences showing 95% or greater homology.

### Isolation of viruses at Coastal Plains Research Station, 1990–1995

During this six year reporting period, five BLU serotypes were isolated at Coastal Plains Research Station (Table 1). The year 1990 was unusual, with no BLU being isolated. Five EHD serotypes (1, 2, 5, 7 and 8) were isolated, as well as the Simbu group viruses Akabane, Aino and Peaton. The isolation of EHD1 was the first time this virus had been detected in Australia. Another new virus, of the Bunyamwera serogroup of the Bunyaviridae, was also isolated, as were other viruses which remain to be fully characterised.

Table 1 also shows the month in which each BLU isolation occurred at Coastal Plains Research Station. In 1991 isolations began late in the season, in May, while in 1992, 1994 and 1995 BLU isolations occurred throughout the wet season, from January to May.

Although BLU1 occurred in two consecutive years, 1993 and 1994, as did BLU21 in 1994 and 1995, the serotypes isolated each year could not be predicted from the previous year's data. BLU3 and BLU16 appeared for one year only. BLU20 appeared in 1992, then again in 1995. The isolations of BLU20 in 1992, the first since the original isolation in 1975 (St. George et al. 1978), came from only two of a

total of 75 animals being monitored for various experimental purposes. Subsequent serum neutralisation testing showed those two to have been the only animals infected with that serotype, whereas 59 of the 75 yielded isolates of BLU16 that same year.

The data highlight our present poor understanding of BLU epidemiology at even such a well monitored site as Coastal Plains Research Station. There is no predictive data and no proven explanations for the serotypes that are active each year, the months in which they infect monitored animals, or the proportion of animals that become infected. New strategies are required to study BLU epidemiology more completely.

Similar patterns were evident among the EHD viruses which were isolated (data not presented). In 1990, when no bluetongue viruses were isolated, three EHD serotypes were recovered: EHD2 was isolated from 44 of 58 animals being monitored, EHD5 from 20 animals and EHD8 from five animals. Such data suggest that vectors were sufficiently abundant to maintain cycles of infection.

### Seroepidemiology

At some sentinel sites, seroconversions to the various viral groups were recorded each year (Table 2). Palyam group viruses tended to be more widely distributed than BLU and EHD viruses, as indicated by the data from Katherine Research Station in 1991 and 1992 and Victoria River Research Services in 1991, 1994 and 1995 (Table 2). From the data, Katherine Research Station and Victoria River Research Services approximately mark the normal boundary of BLU activity, depending on the year. Arid Zone Research Institute showed no reactions to orbiviruses throughout the observation period, confirming its status as usually virus-free.

### Molecular epidemiology

The BLU isolates were studied by sequence analysis of a PCR-amplified fragment of the RNA 3 gene coding for the inner capsid protein VP 3 (Table 3). The isolates included one of each serotype from each

**Table 1.** Isolations of bluetongue viruses at Coastal Plains Research Station, 1990 to 1995, by month.

	Jan	Feb	Mar	Apr	May	Jun	Jul	Aug	Sep	Oct	Nov	Dec
1990	–	–	–	–	–	nt	nt	nt	nt	nt	nt	nt
1991	–	–	–	–	3	3	–	–	–	nt	nt	nt
1992	16	16	16	16	16,20	–	–	–	–	–	nt	nt
1993	–	–	1	1	1	–	–	–	–	nt	nt	nt
1994	1	1	1	1	21	21	–	–	–	21	21	21
1995	21	21	21, 20	20	20							

nt: not tested

year, with the exceptions of BLU1 in 1993 and the 1995 isolates of BLU21. Both isolates of BLU20 in 1992 were studied, as were both isolates of BLU21 from 1994. Computer-assisted groupings are presented in a dendrogram (Fig. 2).

Topotyping of Australian BLU isolates, based on analysis of sequence data, began when Gould (1987) reported that the prototype strains of BLU1 and 9 grouped together, showing less than 5% divergence of sequence homology, while BLU15 was 20% different from the other isolates.

The dendrogram (Fig. 2) shows the relationships of recent isolates (Table 3) with Australian prototype isolates for each serotype. With the exception of BLU15 (B15 Aus, Fig. 2), all prototype serotypes grouped together, as reported previously (Pritchard et al. 1995). Grouping with these prototypes were the isolates V2115, a 1991 isolate of BLU3; V2208, a 1992 isolate of BLU16; V3036, a 1994 isolate of BLU1; and V3209, a 1994 isolate of BLU21. These isolates of BLU1, 3, 16 and 21 can be assumed to represent strains of viruses already adapted to Australian conditions and evolving with the prototype strains.

As reported by McColl et al. (1994), the BLU20 isolates from 1992 are clearly different. These isolates may represent a strain of BLU20 that has evolved separately from the known Australian strains (Gorman et al. 1981), the inference being that they are recent incursions to northern Australia. The 1995 isolate of BLU20, V3594, was different by a similar order of magnitude from both the prototype and the 1992 isolates of BLU20, again indicating an incursion from a different source. The 1995 isolate grouped with an isolate of BLU1 from Malaysia, indicating homology with viruses from a source in Southeast Asia.

Another interesting observation was the comparison of the sequences of two isolates of BLU21 from 1994. Whereas V3209 grouped with the Australian prototype isolates, V3217 showed a sequence markedly different from that of all other isolates made in Australia, and more closely related to an isolate of

BLU1 from India. Both the 1994 isolates of BLU21 studied were recovered from sentinel cattle at Coastal Plains Research Station within a month of each other. Hence the data indicate that two separate strains of BLU21 were circulating among the sentinel cattle at Coastal Plains Research Station at that time.

**Table 3.** Bluetongue isolates sequenced for molecular epidemiological study.

Isolate	BLU serotype	Collection date
V2115	3	May 1991
V2208	16	February 1992
V2400	20	May 1992
V2450	20	June 1992
V3036	1	February 1994
V3209	21	May 1994
V3217	21	June 1994
V3594	20	March 1995

There is much to be learned about the biological causes for the differences detectable among the nucleotide sequences of BLU isolates, and particularly the rate of change in sequence for any strain. Full epidemiological interpretations of the data must wait upon such basic knowledge. However, the detectable differences in sequence among isolates do provide a valuable measure of difference that is immediately useful. Detection of a sequence different from that usually encountered at any location signals a change in the viral fauna, most probably the result of an introduction of new genes in new viruses. New genetic material may equate with new, or increased, risks. For example, the new viruses may have different relationships with the vector species present, and hence may spread more slowly or more rapidly than pre-existing strains. The new viruses may be more pathogenic. The detection of a different genotype warns of a new situation to be monitored, and is also one of the means of undertaking that monitoring.

**Table 2.** Sentinel sites showing seroconversions to orbiviruses in agar gel immunodiffusion (AGID) serogroup tests<sup>a</sup>.

Sentinel Site	1991	1992	1993	1994	1995
	B E P <sup>b</sup>	B E P	B E P	B E P	B E P
Arid Zone Research Institute	---	---	---	---	---
Berrimah Agricultural Research Centre	+++	+++	+++	+++	+++
Coastal Plains Research Station	+++	+++	+++	+++	+++
Douglas Daly Research Farm	+++	+++	+++	+++	+++
Katherine Research Station	+++	+++	+++	+++	+++
Victoria River Research Services	+++	---	+++	---	---

<sup>a</sup> cELISA was used for BLU serogroup testing in 1993, 1994 and 1995.

<sup>b</sup> B - BLU; E - EHD; P - Palyam.

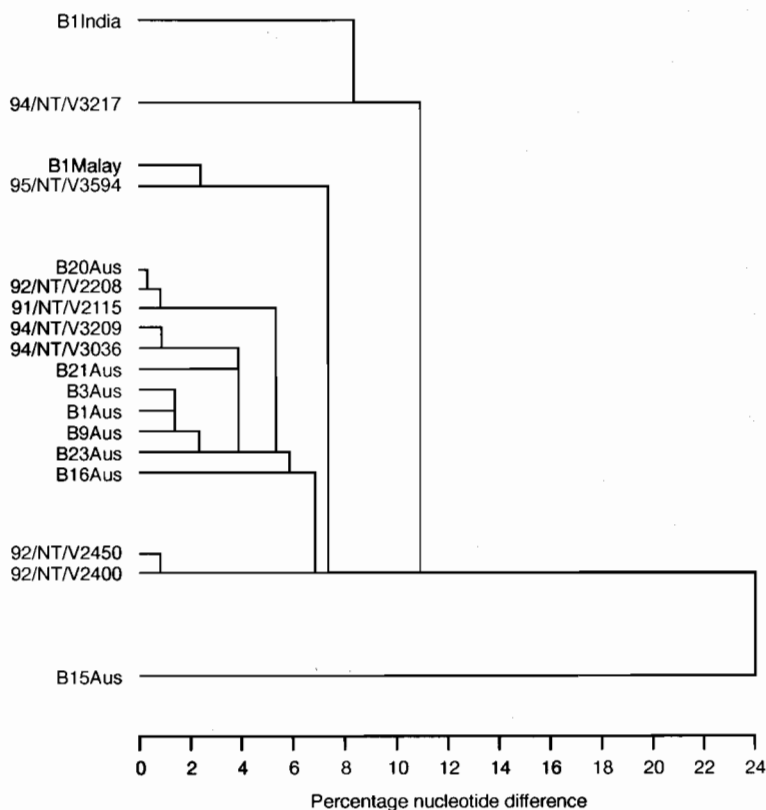

**Figure 2.** Dendrogram showing the relationships among recent Australian bluetongue isolates, as determined by nucleotide sequence analysis.

## Conclusions

Although recent monitoring of sentinel herds in the Northern Territory has not yielded isolations of BLU serotypes additional to those known since 1986 (Gard et al. 1988), valuable information has been obtained. The unpredictability of arboviral infections has been emphasised, highlighting the need for new epidemiological studies to increase our understanding of BLU epidemiology. New viruses such as EHD1 and the Bunyamwera serogroup virus have been isolated, reinforcing our awareness that northern Australia is part of a broader East Asian ecosystem for arboviruses, and thus subject to introductions of new viruses on a continuing basis. That this is true for bluetongue viruses was identified by genotype analyses of recent BLU isolates, where serotype has suggested an apparently familiar phenotype. Nucleotide sequence analysis has identified several isolates of BLU20 and 21 that are new to Australia. In future, effective monitoring strategies must attempt to apply newer approaches, both in Australia and in the

region, to detect changing risks, and to develop the capacity to analyse changes so as to develop appropriate responses.

## Acknowledgments

This work was substantially funded by the Northern Australian Quarantine Strategy of the Australian Quarantine and Inspection Service (AQIS). Dr Daniels was supported by the Exotic Animal Disease Consultative Council (EXANDIS), which also partly funded the molecular analyses of bluetongue viruses.

## References

- Felsenstein, J. 1985. Confidence limits on phylogenies: an approach using the bootstrap. *Evolution*, 39, 783-791.
- Gard, G.P. and Melville, L.F. 1992. Results of a decade's monitoring for orbiviruses in sentinel cattle pastured in an area of regular arbovirus activity in northern Australia. In: Walton, T.E. and Osburn, B.J., ed., *Bluetongue, Afri-*

- can horse sickness and related orbiviruses. Proceedings 2nd International Symposium. CRC Press, Boca Raton, 85-89.
- Gard, G.P., Weir, R.P. and Walsh, S.J. 1988. Arboviruses recovered from sentinel cattle using several virus isolation methods. *Veterinary Microbiology*, 18, 119-125.
- Gorman, B.M., Taylor, J., Walker, P.J., Davidson, W.L. and Brown, F. 1981. Comparison of bluetongue type 20 with certain viruses of the bluetongue and Eubengangee serological groups of orbiviruses. *Journal of General Virology*, 57, 251-261.
- Gould, A.R. 1987. The complete nucleotide sequence of bluetongue virus serotype 1 RNA3 and a comparison with other geographic serotypes from Australia, South Africa and United States of America, and with other orbivirus isolates. *Virus Research*, 7, 169-183.
- Lunt, R.A., White, J.R. and Blacksell, S.D. 1988. Evaluation of a monoclonal antibody blocking ELISA for the detection of group specific antibodies to bluetongue virus in experimental and field sera. *Journal of General Virology*, 69, 2729-2740.
- McColl, K.A. and Gould, A.R. 1994. Bluetongue virus infection in sheep: haematological changes and detection by polymerase chain reaction. *Australian Veterinary Journal*, 71, 97-101.
- McColl, K.A., Gould, A.R., Pritchard, L.I., Melville, L. and Bellis, G. 1994. Phylogenetic characterisation of bluetongue viruses from naturally-infected insects, cattle and sheep in Australia. *Australian Veterinary Journal*, 71, 102-105.
- Pritchard, L.I., Gould, A.R., Wilson, W.C., Thompson, L., Mertens, P.P.C. and Wade-Evans, A.M. 1995. Complete nucleotide sequence of RNA segment 3 of bluetongue serotype 2 (Ona-A). Phylogenetic analyses reveal the probable origin and relationship with other orbiviruses. *Virus Research*, 35, 247-261.
- Saiki, R.K., Gelfand, G.H., Stoffel, S., Scharf, S.J., Higuchi, R., Horn, G.T., Mullis, K.B. and Erlich, H.A. 1988. Primer-directed enzymatic amplification of DNA with a thermostable DNA polymerase. *Science*, 239, 487-491.
- Sanger, F., Nicklen, S. and Coulson, R.A. 1977. DNA sequencing with chain-terminating inhibitors. *Proceedings of the National Academy of Science of the USA*, 74, 5463-5467.
- St. George, T.D., Standfast, H.A., Cybinski, D.H., Dyce, A.L., Muller, M.J., Doherty, R.L., Carley, J.G., Filippich, C. and Frazier, C.L. 1978. The isolation of a bluetongue virus from *Culicoides* collected in the Northern Territory of Australia. *Australian Veterinary Journal*, 54, 153-154.
- St. George, T.D., Cybinski, D.H., Della-Porta, A.J., McPhee, D.A., Wark, M.C. and Bainbridge, M.H. 1980. The isolation of two bluetongue viruses from healthy cattle in Australia. *Australian Veterinary Journal*, 56, 562-563.

# Establishment of Sentinel Herds to Monitor Bluetongue in China

Li Huachun\*, Li Zhihua\*, Zhou Fuzhong\*, Ben Jin\*, Zhang Khaili\*, Liu Gui\*, Li Chundi<sup>†</sup>, Zhang Yingguo<sup>†</sup>, Shi Wenbao<sup>§</sup>, Zhao Jinguang<sup>§</sup>, Wang Jiayen<sup>§</sup>, Du Jinwen<sup>§</sup>, Kong Dehui<sup>¶</sup>, Yang Guanghua<sup>¶</sup>, Niu Baosheng\*\* and Niu Yongfu\*\*

## Abstract

Sentinel herds have been used in Australia since 1969 to monitor endemic virus infections of livestock. The technique, developed in Australia, has since been introduced to New Zealand, Papua New Guinea, Indonesia, Malaysia, USA, Canada, Central America and the Caribbean. In 1984, sentinel herds were established for a Sino-Australian ephemeral fever project in northeast China. In 1991, the first sentinel group for bluetongue, a disease first recognised in China's Yunnan Province in 1979, was established near Kunming. The herd comprised 15 goats and two cattle. This paper reports the establishment and operation of three more sentinel herds in Yunnan, in Shizong County and at two sites in Eshan County (12 cattle, 10 cattle and 15 goats respectively).

BLUETONGUE is an arthropod-borne viral infection, transmitted by biting insects. As bluetongue virus (BLU) does not cause obvious clinical disease in cattle, buffalo or goats, serological methods must be used to determine if animals have been infected. Viraemic animals introduced to an area where *Culicoides* vectors are active may be a source of infection for susceptible sheep. One way of monitoring BLU activity in an area is to establish sentinel animals, then test their sera for antibodies and isolate viruses from their blood. An understanding of virus distribution and activity can help in planning control measures.

Bluetongue disease was first discovered in China in 1979, in Yunnan Province, with serotype BLU1

being isolated from sick sheep (Zhang Nianzu et al. 1989a). During the subsequent nationwide bluetongue survey, antibodies were found in most provinces of China. BLU1 was later isolated from sentinel goats at Xinjiang and Inner Mongolia and from sick sheep at Shanxi, while BLU16 was isolated from sheep at Sichuan and Hubei.

## Materials and Methods

To investigate the distribution of BLU serotypes, four sentinel herds were established in Yunnan Province; at Kunming, Eshan (two sites) and Shizong. These herds, comprising two groups of 15 goats, one group of 10 cattle and another of 12 cattle, were regularly bled for serology and virus isolation.

### Preliminary survey to select sites for sentinel herds

Before the establishment of sentinel herds, blood samples were taken from cattle, buffalo, goats and sheep in the candidate villages and tested for BLU antibodies. This involved the testing of 47 animals (30 goats and 17 cattle) from Shuanglong Village in Kunming, 94 (40 goats, 15 sheep, 17 cattle and 22 buffalo) from Shizong County and 104 (54 goats, 22 cattle and 28 buffalo) from Eshan County. Sera were

\* Yunnan Tropical and Subtropical Animal Virus Diseases Laboratory, Jindian 650224, Kunming, People's Republic of China.

<sup>†</sup> Yunnan Provincial Station for Veterinary Prevention, Kunming 650021, People's Republic of China.

<sup>§</sup> Eshan Station of Veterinary Medicine, Eshan 653200, People's Republic of China.

<sup>¶</sup> Qujing District Station of Veterinary Medicine, 655000, People's Republic of China.

\*\* Shizong Station of Veterinary Medicine, Shizong 655700, Yunnan, People's Republic of China.

tested by competitive enzyme linked immunosorbent assay (cELISA) and agar gel immunodiffusion (AGID): positive sera were tested with standard neutralisation tests using Chinese isolates of BLU1 or BLU16.

### Sentinel animals

Overall, four sentinel herds were established (Table 1). In September 1994, a sentinel herd was established at Shuanglong Village, 30 km north of Kunming (altitude 2000 m above sea level). The herd comprised 16 goats and 2 cattle aged under one year, all tested negative for bluetongue by AGID and cELISA. Blood samples were taken weekly from September to October 1994 and monthly from November 1994 to July 1995.

**Table 1.** Location, composition and date of establishment of sentinel herds

Location	Date of establishment	No. of cattle	No. of goats
Kunming	9 September 1995	2	15
Shizong	13 July 1995	12	0
Eshan 1	28 February 1995	10	0
Eshan 2	1 May 1995	0	15

In 1995, another herd, comprising 10 local Yellow cattle, was established at Baoqian Village in Eshan County, 150 km south of Kunming (altitude 1400 m; average annual rainfall 1041 mm; average annual temperature 16.2°C). Blood samples were taken monthly from 28 February to April 1995. In May 1995, 15 goats were substituted for the positive sentinel cattle and weekly blood samples were taken from May to July 1995.

To establish another sentinel herd, 12 local Yellow cattle bought from the sentinel village at Shuanglong (see above) were relocated to Wulong Village in Shizong County, 260 km east of Kunming (altitude 1600 m; average annual rainfall 1800 mm; average temperature 13.5°C). Weekly blood sampling began on 19 July 1995.

**Table 2.** Bluetongue serological survey results from the Shizong sentinel site.

Species	Total no. of animals	cELISA positives	AGID positives	Serum neutralisation positive serotypes		
				BLU1	BLU15	BLU16
Buffalo	22	18	13	3	0	0
Cattle	17	10	5	1	0	0
Goats	40	9	1	0	0	0
Sheep	15	0	3	0	0	0
Total	94	37	22	4	0	0

Animals were bled using evacuated bleeding tubes with 1.2 × 40 mm needles. Sera and clots were separated, numbered and recorded. Sera were stored in a serum bank, and blood and clots held at 4°C for virus isolation.

### Serology

Sera from the sentinel herds were tested using AGID (Zhang Nianzu et al. 1989b), with antigen made from BLU1 (YF8). Reference sera were made at the Yunnan Tropical and Subtropical Animal Virus Diseases Laboratory. The sera were also tested by cELISA, as described by Gard and Kirkland (1993), using kits produced by Tropical Biotechnology, Townsville, Queensland, Australia. Microneutralisation tests were carried out by modified standard procedures (Gard and Kirkland 1993).

### Virology

Heparinised blood and clots from preliminary survey samples, and from monthly or weekly samples of sentinel herds in Kunming, Shizong and Eshan, were processed for virus isolation. Heparinised blood (0.1 mL) or uncoagulated red cells (0.1 mL) from a clot were diluted in 0.9 mL sterile distilled water (pH 7.2–7.4) to lyse blood cells. Four 10-day-old embryonated hen eggs were inoculated intravenously (0.1 mL of inoculum per egg). Eggs dying one to five days post-inoculation were harvested separately from embryos alive after five days. The heads and legs of the embryos were removed, the body ground in a tissue stomacher with 5 mL diluent, and the supernatant stored in centrifuge tubes for inoculating cells.

## Results

### Preliminary survey

The preliminary survey involved the testing of blood samples from 245 animals in Kunming, Shizong and Eshan. While all 47 animals from Kunming were negative for BLU by AGID and cELISA, some animals from both Shizong and Eshan tested positive (Tables 2 and 3 respectively).



**Table 3.** Bluetongue serological survey results from the Eshan sentinel sites.

Species	Total no. of animals	cELISA positives	AGID positives	Serum neutralisation positive serotypes		
				BLU1	BLU15	BLU16
Buffalo	28	21	19	14	3	4
Cattle	22	18	6	0	0	0
Goats	54	6	4	0	0	0
Total	104	44	29	14	3	4

**Sentinel herds**

Of the 10 cattle at Eshan, five were positive for BLU antibodies by AGID (four weak positive and one strong positive) and seven positive by cELISA (Tables 4a and 4b). Three of the ten were seronegative by AGID and cELISA. The positive animals were all older than one year while the negative ones were all aged from 0.6 to one year. Because

most of the sentinel cattle had BLU antibodies, an additional group of 15 BLU-negative sentinel goats were located at the same village in May 1995 and bled weekly. Until 2 June, all goats remained negative by AGID and cELISA. Virus isolations from blood and clot samples from the Eshan herds have not yet been completed. Lysed blood has been inoculated into embryonated hen eggs.

**Table 4a.** Serological results from the Eshan sentinel cattle, 28 February to 19 May 1995.

Date Animal no.	28 February 1995		28 March 1995		28 April 1995		12 May 1995		19 May 1995	
	cELISA	AGID	cELISA	AGID	cELISA	AGID	cELISA	AGI	cELISA	AGID
1	95	1	199	1	199	9	NT	0	NT	3
2	0	0	0	0	0	0	NT	0	NT	0
3	0	0	0	0	0	0	NT	0	NT	0
4	100	1	100	2	100	2	NT	0	NT	2
5	0	1	0	0	0	0	NT	1	NT	0
6	93	1	100	1	100	1	NT	0	NT	3
7	100	1	100	1	100	1	NT	0	NT	2
8	92	1	100	1	100	1	NT	1	NT	1
9	96	1	100	0	100	0	NT	1	NT	1
10	98	0	100	0	100	0	NT	0	NT	1

NT=not tested

**Table 4b.** Serological results from Eshan sentinel cattle, 26 May to 23 June 1995 (cELISA tests not completed).

Date Animal no.	26 May 1995 AGID	2 June 1995 AGID	9 June 1995 AGID	16 June 1995 AGID	23 June 1995 AGID
1	0	0	1	1	1
2	0	0	0	0	0
3	0	0	0	1	0
4	0	1	1	1	2
5	0	0	0	0	0
6	2	2	2	3	3
7	0	0	1	0	2
8	0	1	1	1	1
9	0	0	0	1	1
10	0	2	1	0	1

The sentinel goats and cattle at Shuanglong Village in Kunming were bled 18 times from September 1994 to July 1995. All AGID and cELISA results were negative. Serological testing and virus isolation from the Shizong site are still in progress.

## Discussion

Understanding the activity and distribution of bluetongue virus is very complex in Yunnan Province: as 94% of the area is mountainous, altitudes and climates vary from site to site. The selection of sites and animals for sentinel herds is important. It is essential first to survey animals in an area to determine sites where BLU is active, then to move seronegative animals, if necessary, from a place free of BLU antibody to the site where the sentinel herd is to be established. If the animals were born in the village where they will be used as sentinels, it is best to select and test animals aged 0.6–1 year: this minimises interference from maternal BLU antibodies and overcomes the difficulty of finding seronegative animals.

At the Kunming sentinel site, there were no BLU-positive animals among the 47 in the preliminary survey, and none of the 15 goats and 2 cattle showed seroconversion. This suggests there is no bluetongue virus activity around the area of Shuanglong Village in Kunming.

In Shizong, of the 94 animals in the preliminary survey, 37 were BLU-positive by cELISA and 22 positive by AGID. Serum neutralisation (SN) tests indicated the presence of BLU1 antibodies. A group of 12 sentinel cattle has been moved from Shuanglong Village, which is bluetongue-free, and serology and virus isolation will be performed to monitor activity at Shizong during the 1995 season of virus activity.

In Eshan county, 104 cattle and goat serum samples were collected from Eshan County in the prelim-

inary survey: 44 animals were BLU-positive by cELISA and 29 positive by AGID. Neutralisation tests indicated the presence of BLU1, 15 and 16 antibodies. Of the 10 sentinel cattle, seven were BLU positive, making it difficult to detect infection by seroconversion. Future work will involve identification of BLU serotypes by neutralisation tests and isolation of virus from blood samples. An additional sentinel herd of 15 goats free from BLU antibodies has been introduced.

In summary, the serological results of a preliminary survey at Shuanglong (Kunming), Shizong and Eshan in Yunnan Province indicated that there had been no BLU activity in recent years at Shuanglong (Kunming), and that Shizong and Eshan were suitable places for establishing bluetongue sentinel herds. Serology (by AGID, cELISA and SN) and virus isolation for the sentinel herds are still in progress. It is hoped to establish more sentinel herds in the southern counties of Yunnan Province with the collaboration of county veterinary stations. The establishment of sentinel herds in other Provinces is also being discussed.

## References

- Gard G.P. and Kirkland, P.D. 1993. Bluetongue Virology and Serology. Australian Standard Diagnostic Techniques for Animal Diseases. East Melbourne, CSIRO Information Services, 8–10.
- Zhang Nianzu, Hu Yuling, Li Zhihua, Li Gen, Zhang Khaili and Zhou Fuzhong. 1989b. The making and specific testing of bluetongue AGID antigen. *Yunnan Animal Husbandry and Veterinary Journal*, 4, 13–16.
- Zhang Nianzu, Zhang Khaili, Li Zhihua, Shanyu Naishun, Hu Yuling, Li Gen, Zhao Kun, Zhou Fuzhong and Xu Wenzhen. 1989a. Investigation and study of bluetongue disease of sheep in Yunnan, China. *Yunnan Animal Husbandry and Veterinary Journal*, 4, 3–12.

# Epidemiological Considerations in the Study of Bluetongue Viruses

P.W. Daniels\*, I. Sendow† and L.F. Melville§

## Abstract

Epidemiological studies of bluetongue viruses depend on understanding certain key features of the biology of the 24 serotypes. Bluetongue viruses are arboviruses, spread by insect vectors comprising some species in the genus *Culicoides*. Among ruminant hosts, cattle are the major reservoir or amplifier host, with only some breeds of sheep showing disease. Bluetongue viruses have both serotype and serogroup reactive antigens, and also show serological cross-reactions with other viruses. Serological tests must be interpreted on the basis of this knowledge. The distribution of bluetongue viruses can be mapped through serological surveys, but confirmation of virus presence in any area requires virus isolation. Monitoring sentinel groups of animals at frequent intervals allows both isolations and descriptions of seasonal patterns of seroconversions. Isolating viruses from insects allows identification of potential vectors, which must be confirmed by experimental transmission studies. Molecular virology allows comparison of sequence data from isolates, so that the relationships between viruses in different geographical areas can be studied. Pathogenicity does not depend on serotype but must be tested experimentally to determine the potential economic problem constituted by viruses from a given area. The financial cost to farmers, a major consideration in any epidemiological study, can only be determined by accurate on-farm records and accurate diagnosis of disease outbreaks. The application of these principles has been demonstrated in northern Australia and Indonesia, with good results. Much is now known of the distribution of the bluetongue virus group in these neighbouring countries, and eight bluetongue serotypes have been isolated from sentinel cattle in both countries.

BLUETONGUE viruses are arboviruses, so their epidemiology depends on their vectors, insects of the genus *Culicoides*. Epidemiological studies of arboviruses are incomplete without integrated vector studies (Daniels et al. 1991). Only a few species of *Culicoides* act as vectors, so to understand local influences on virus epidemiology each country or site must know which of its insect species are competent vectors; the relative infection rates of these species; and other aspects of insect biology.

Bluetongue viruses form a serogroup in the genus *Orbivirus*, members of which have 10 double stranded RNA segments. Two structural proteins, VP3 and VP7, form the inner capsid carrying serogroup-specific antigens. The outer capsid comprises two structural proteins, VP2 and VP5, carrying serotype-specific antigens (Huismans and Erasmus 1981). The close antigenic relationships among members of the *Orbivirus* genus gives rise to serological cross-reactions among the antibodies to the serogroup antigens (Della-Porta et al. 1985). Serological studies to detect exposure to bluetongue group viruses should use tests designed to overcome this problem.

Within the bluetongue virus (BLU) serogroup, there are 24 serotypes, distinguished on the basis of serological neutralisation tests. However, detection of serotype-specific antibody in an animal does not prove infection with that serotype, since heterotypic

\* CSIRO Australian Animal Health Laboratory, PO Bag 24, Geelong, Victoria 3220, Australia.

† Research Institute for Veterinary Science, PO Box 52, Bogor 16114, Indonesia.

§ Department of Primary Industry and Fisheries, Berrimah Agricultural Research Centre, PO Box 79, Berrimah, Darwin, Northern Territory 0828, Australia.

antibody responses may develop after exposures to two or more serotypes, resulting in the presence of neutralising serotypic antibodies in animals not exposed to these serotypes (Della-Porta et al. 1985). Confirmation of the presence of any BLU serotype at any geographic location should be based on isolation of the virus rather than on serological responses in exposed animals. Although ruminants are the mammalian hosts for bluetongue viruses, the patterns of infection and disease among these hosts are not understood completely.

### **Bluetongue Disease or Bluetongue Infection?**

Epidemiologically, it is essential to distinguish between bluetongue disease and bluetongue infections. The epidemiology of the disease cannot be understood without understanding that infection only rarely results in disease. Conversely, the ecology of bluetongue virus infections cannot be understood if disease is used as a marker of infection. Two factors are of major importance. First, among ruminant hosts, there is considerable variation in species and breed susceptibility. Second, among the viruses there is considerable variation in strain pathogenicity that is independent of serotype.

For example, in Indonesia, bluetongue disease has been reported only in imported Suffolk sheep (Sudana and Malole 1982). Nevertheless, serological studies have shown cattle and buffaloes have higher prevalences of BLU infection than small ruminants, but show no associated disease (Sendow et al. 1986, 1991). Local (hair) sheep and goats show lower but significant prevalences of infection, but no disease has been reported in these breeds either.

This pattern, of high prevalences of infection but low or no occurrence of disease, has been recognised frequently in tropical and subtropical countries (Gibbs 1992). Breed susceptibility has been recognised as one factor, with introduced European breeds of sheep being more susceptible than local sheep breeds. Cattle are virtually non-susceptible to bluetongue disease, but are highly susceptible to BLU infection, with periods of viraemia lasting several weeks (MacLachlan et al. 1992; Melville and Hunt these Proceedings). Cattle are amplifier hosts of infection. Erasmus (1975a) considered a cattle-vector cycle adequate to maintain bluetongue viruses in the environment, and further suggested that sheep are merely accidental hosts.

Nonetheless, bluetongue is an Office International des Epizooties (OIE) List A pathogen because of the severe clinical disease, accompanied by high mortalities that does occur where susceptible breeds of sheep are infected with pathogenic virus strains (Erasmus

1975b). Hence, the purpose of any epidemiological study must be defined in terms of whether its subject is the disease or the infection. Clearly, studying the infection is necessary for any study of the disease, but often bluetongue infections are studied in the absence of any associated disease, frequently focussing on cattle, considered the main BLU host.

### **Basic Epidemiological Studies of Bluetongue Infection**

Bluetongue virus infections are studied as one of the major risk factors associated with bluetongue disease. Where bluetongue disease is an existing or potential problem, knowledge is required of all aspects of BLU infections in both 'silent' and susceptible hosts, and in vectors. Many countries seek to protect their susceptible ruminant livestock through quarantine barriers, restricting movement of livestock and germplasm. Exporting countries thus need to have knowledge of their bluetongue infection status to support regional or global international trade. Ideally, importing countries will also clarify their own bluetongue infection status so as not to interrupt trade unnecessarily. Studies of bluetongue infections commonly include serological surveys, monitoring of sentinel herds, and vector studies, each of which is described in some detail below.

### **Serological (Cross-sectional) Surveys**

In the epidemiology of bluetongue, serological surveys are useful primarily to define areas of risk, based on the usual infection status of the ruminants in the area. Countries may comprise zones of different infection status, and serological surveys help define the boundaries of these zones. Usually it is most important to identify areas where bluetongue infections are present or absent. In large countries, such as Australia, that have both infected and uninfected areas, there is little benefit in blending data, for example to give an overall prevalence of infection for that country. Rather, the information most useful to livestock producers and traders are the boundaries between zones where animals are possibly infected and zones where they are not. This allows assessment of the risk to livestock enterprises.

The risk of disease in susceptible sheep, or the risk of including a seropositive animal in a shipment for export, may be presumed to be higher where the incidence of infections is higher. Surveys therefore also may be used to define areas of high and low prevalence. In some countries or regions, such as northern Australia, some BLU serotypes are restricted to certain geographical areas. In such cases, serological

surveys have helped define the boundaries of the restricted area.

However, there are problems associated with cross-sectional serological surveys as an epidemiological technique. First, surveys give a single view of a changing situation. Second, the history of sampled animals is often not known with reliability. Third, some bluetongue serological tests are difficult to interpret because of cross reactive group antibodies and heterotypic antibodies (for example with the EHD serogroup). To be accurate, serological surveys for BLU group viral infections must use the cELISA test (Lunt et al. 1988) to avoid the problem of cross reactions experienced with other tests, such as the agar gel immunodiffusion (AGID) test (Della-Porta et al. 1985).

Bluetongue viruses are spread by vectors, the range of which may vary each year depending on the suitability of the climate for the vector's survival, especially at the edge of its range. This means that a survey conducted just once will give information only on virus distribution in the current or previous seasons. To monitor the distribution of a BLU infection over longer periods of time, serological surveys would have to be repeated at frequent intervals. Properly conducted surveys are expensive, both in the sampling phase and in the need to test an adequate number of samples for a defined level of confidence.

In many countries, livestock are highly mobile, being traded frequently. It may be uncertain whether an animal has spent its whole life at the location where it is being sampled: this in turn gives rise to doubt whether its antibody status accurately reflects BLU infections at that location. Similarly, there may be difficulties associated with the age of animals sampled in a survey. Older animals may have been exposed more often than younger animals to risks of infection, so results from a survey have to be corrected for age, which itself may be difficult to assess accurately. More frequent exposures, particularly to multiple serotypes, increase the probability of finding serotype-specific antibodies to serotypes other than those infecting the animal. Attempting differentiation between these heterotypic and 'real' responses can be difficult, and almost arbitrary. Serotype-specific information in which complete confidence can be placed may be unobtainable from a survey, particularly if older animals are sampled.

Serological surveys do have particular uses. A well planned and conducted survey, with a statistically valid sampling protocol (Cannon and Roe 1982), can give preliminary information about infections in livestock across a wide area, including susceptibility of different species to infection and probable boundaries between areas of different infection status. In these ways survey results can assist with the planning of

other epidemiological investigations, such as the use of sentinel herds.

In Indonesia, for example, a preliminary serological survey showed that bluetongue infections were widely distributed on all the major islands, and that cattle and buffaloes had higher prevalences of infection than sheep and goats (Sendow et al. 1986, 1991). Cattle were subsequently chosen as sentinel animals (Sendow et al. 1992). In Australia, serological surveys have shown that bluetongue infections have a boundary contiguous with that of the most widely distributed *Culicoides* vector species (Della-Porta et al. 1983). Such surveys have also shown that, of eight BLU serotypes known in Australia, only two have spread from a northern focus to states on the eastern half of the continent (Ward et al. 1995). A more recent survey has defined further the boundaries of this northern focus of the remaining six restricted serotypes (Fig. 1; Daniels and Melville, unpublished data). Hence, the cross-sectional survey is useful for describing the patterns of exposure in the populations under investigation, information that can be used as the basis for further decisions.

## Sentinel Herds

Sentinel herds (St. George 1980) are a form of structured surveillance, with a design analogous to the prospective, or cohort, study format. As such, they are one of the more powerful investigative strategies available to epidemiologists. Advantages of sentinel herd programs are those of prospective studies in general, as outlined in standard epidemiology textbooks. In particular:

- incidence rates can be estimated;
- the timing of infections can be observed;
- animals of known source and history of exposure can be sampled;
- management variables, such as insecticide use, can be controlled;
- program design can be flexible in terms of sampling frequency and choice of test;
- as the definitive test, the sampling design can accommodate attempted virus isolation, which is a more precise estimate of infection status than serology; and
- a flexible response to events can be a design feature; this may involve changing the sampling or testing procedure upon first observing infection in the group.

In bluetongue epidemiology, the primary purpose of a sentinel herd program, or of an individual sentinel group, is to detect BLU infections occurring at a particular place. Thus the identifying characteristic of the cohorts is their location. Evidence for BLU infec-

more precise estimate of infection status than serology; and

- a flexible response to events can be a design feature; this may involve changing the sampling or testing procedure upon first observing infection in the group.

In bluetongue epidemiology, the primary purpose of a sentinel herd program, or of an individual sentinel group, is to detect BLU infections occurring at a particular place. Thus the identifying characteristic of

the cohorts is their location. Evidence for BLU infections at different locations can then be compared, as can the effect of secondary factors, such as climate, that may influence events at each location. To avoid confounding factors, sentinel groups should comprise animals of similar age and susceptibility to BLU infection. Based on the considerations outlined above and described by Erasmus (1975a), yearling cattle are the most appropriate sentinels of BLU infection, even though they will not show bluetongue disease. The only feature distinguishing groups of sentinels should be geographical location.

Care is also necessary in choosing the actual site for the sentinel group. The aim is to maximise the chance of detecting viral activity at the geographical location for which the sentinel site acts as a sampling point. Alternatively stated, the purpose, particularly for monitoring, is to disprove, with as rigorous a challenge as possible, the null hypothesis that infections with bluetongue viruses do not occur in the geographical area under study. Hence the sentinel site should be in a local environment that is suitable for vector activity and adjacent to other mammalian hosts, where any infections in the area may be expected to spread readily.

Sera from surveys and sentinel herd programs should be stored methodically in a serum bank (St. George 1979; Young et al. 1985), which allows retrospective studies in the event of new viruses or serotypes being isolated, as described by St. George (1980) and Gard and Melville (1989).

### Designing a sentinel program

The design of a sentinel herd program will reflect a compromise between the purposes and the resources available. This will affect the number of locations (sentinel sites) established, the frequency of sampling and the choice of test performed on the samples.

### Virus isolation

The definitive measure of a region, country or zone's bluetongue infection status is the isolation of viruses and their identification to serotype. Clinical disease can identify an animal from which virus may be expected to be isolated but, as explained above, most BLU infections of livestock are asymptomatic. Experience has shown that the most efficient way to isolate arboviruses is to sample mammalian hosts prospectively at frequent intervals over the period when exposure may be expected, to ensure that a sample is collected during the viraemic period of each infection. This strategy has yielded isolates of multiple BLU serotypes in both Australia and Indonesia (St. George et al. 1980; Gard and Melville 1992; Daniels et al. 1996; Sendow et al. these Proceedings).

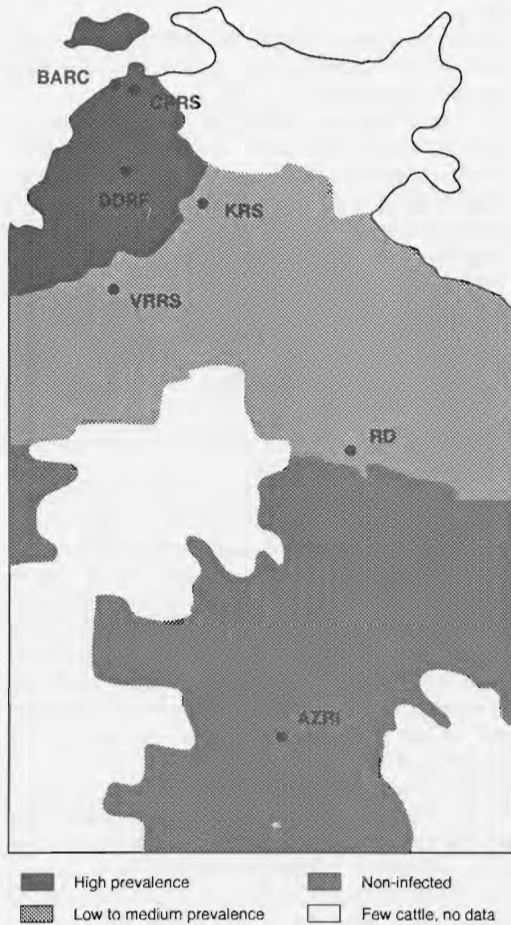

**Figure 1.** Zones of bluetongue viral activity in the Northern Territory of Australia, as defined by serological surveys and monitored by sentinel herds. Sentinel herd sites: BARC, Berrimah Agricultural Research Centre; CPRS, Coastal Plains Research Station; DDRF, Douglas Daly Research Farm; KRS, Katherine Research Station; VRRS, Victoria River Research Station; RD, Rockhampton Downs; AZRI, Arid Zone Research Institute.

of embryonated chicken eggs (Gard et al. 1988). If resources are limited, weekly sampling may be restricted to that period of the year when vector and virus activity is considered most likely.

### Monitoring

To detect changes in the distribution of monitored viruses beyond their normal range, sentinel groups may also be located on the usual boundaries of infected zones. In this case, an adequate observation may be the appropriate serological test, with the sampling frequency being one sufficient to detect a sero-conversion in an appropriate time frame. For example, if monitoring is for trade support purposes (that is, to certify areas as infected or free), then sampling at the beginning and end of the expected vector season may be adequate. However, if the purpose is to detect movement of virus towards susceptible sheep, then more frequent sampling may be needed.

### Description of seasonal patterns

An integral part of the epidemiological descriptions of arboviruses is knowledge of their seasonal patterns of infection, which usually result from climatic influences on vector populations. Monthly serological observations on sentinel groups can identify, with considerable accuracy, the temporal patterns at each location (Sendow et al. 1992), and possibly identify movements between locations.

For example, Australia has implemented a National Arbovirus Monitoring Program based on sentinel herds (Kirkland et al. these Proceedings) to confirm each year the infected or non-infected status of designated zones. In northern Australia, one of these sentinel herds is located in an infected area known by previous experience (Gard and Melville 1992), and confirmed by serological surveys, as the focus of infections with the full range of eight BLU serotypes known in Australia (Fig. 1). The site is sampled weekly for virus isolation, to detect any changes in the BLU strains present. Other sentinel groups, sampled monthly for serology, monitor the spread of usually restricted serotypes beyond their usual distribution, as defined by previous serological surveys (Fig. 1). Monitoring a southern sentinel site in the uninfected zone twice each year, before and after the summer, gives confidence that that zone remains uninfected. Thus the program comprises sentinel groups of cattle strategically placed for different purposes, and sampled and tested differently according to that purpose.

## Vector Studies

Bluetongue viruses are spread by vectors. Movement of infected animals is relatively unimportant in the

spread of infections, and movement of uninfected, seropositive animals appears of no consequence (St. George these Proceedings). Vector studies are an essential component of BLU epidemiological studies. The primary objective is to identify positively the vector species in each country or region, and establish those aspects of the vectors' biology that affect the patterns of virus spread.

Confirmation of vector status of an insect species is a multi-step process:

- the strength of the association between the vector species and its mammalian hosts must be considered;
- bluetongue viruses should be detectable in specimens of the suspect vector species that have been caught in the wild;
- the insect species should be shown to become infected through feeding on a source of virus; and
- most importantly, the species must be demonstrated to be able to transmit the virus biologically unless experimental work has established this last criterion, an insect species cannot be proven as a vector (Standfast et al. 1992).

Once the vector species in each country or region have been identified, further epidemiological information is needed for a full understanding of patterns of infection, or for modelling. This information includes the seasonal abundance of the vector species, and the infection rates of the vectors for the relevant arboviruses or serotypes.

Some *Culicoides* species breed in cattle faeces, and so may be distributed together with the main mammalian host to the limits of climate that are compatible with vector survival. Conversely, vector species with a restricted habitat do not pose a threat in spreading the virus beyond the confines of their habitat, even if they are highly efficient vectors. To be useful for either descriptive or predictive purposes, an epidemiological understanding of BLU infection must include knowledge of the factors limiting the distribution of each vector species.

Experimental studies of infection rates of vector species (Standfast et al. 1992) give an estimate of the probable efficiency of the vector in spreading bluetongue infections among mammalian hosts. Again, any conceptual model of the way bluetongue viruses survive in the environment, and of the way cycles of infection occur, will depend on such knowledge for each vector species. Where the important vector species are known, they can be monitored to detect and analyse changing risks of transmission of viral infections.

### PCR detection of viruses in insects caught in the wild

Insects are frequently caught in light traps and stored in 70% alcohol before identification, allowing



samples to be obtained from remote areas (Sukarsih et al. 1993). However, such specimens are not suitable for subsequent virus isolation or for serologically-based antigen detection techniques. Amplification of viral nucleic acid by the polymerase chain reaction (PCR) offers a means of identifying BLU presence in such specimens (McColl and Gould 1991; McColl et al. 1994). Thus PCR provides a new technique for making observations in epidemiological studies.

As with any test system, correct application depends on standardisation of the test in each of the circumstances in which it may be applied. Primers controlling the PCR can be designed to be BLU group specific, or to allow detection of specific serotypes (McColl and Gould 1991). The sensitivity of each PCR must be established. Current work is investigating the sensitivity of the BLU group PCR in alcohol-fixed insect preparations (Melville and Hunt these Proceedings).

Two unique applications are being developed for PCR detection of bluetongue viruses in insects. In the first, observations on the cycle of BLU infections in sentinel cattle are being extended by examining the infections in *Culicoides* vector species occurring at the sentinel site at the same time. It will thus be possible to describe the complete cycle of virus infection through both vector and mammalian hosts. As described above, the infection status of sentinel cattle in northern Australia is determined regularly by virus isolation. Concomitant studies of PCR detection of BLU in insects sorted to species should allow determination of the vector species introducing the virus to the herd, and of the vector species propagating the wave of infection through the herd. The species still infected at the end of the infection cycle may have a role in maintaining virus in the environment, through virus spread to adjacent groups of uninfected mammalian hosts. Furthermore, comparisons can be made of the dynamics of infection cycles of different BLU serotypes, to attempt to explain the different patterns of spread observed among serotypes (Fig. 1).

After the sensitivity of PCR detection of virus in alcohol-fixed insects has been established with confidence, PCR should be a useful monitoring tool in locations where the sampling of mammalian hosts is not practical. PCR testing of pools of insects from remote areas may allow detection of bluetongue viruses in such locations, if needed for monitoring or during the response to emerging situations identified by routine monitoring. Since the only aim would be to detect virus, not to identify potential vectors, it would not be essential to identify insects to species in a routine monitoring situation. However, use of PCR would be more focussed, and hence more efficient, if just pools of known vectors were processed. These applications depend on existing knowledge for their

usefulness. In northern Australia, experimental studies have already identified the vector species (Standfast et al. 1992), and an efficiently functioning sentinel herd program provides the framework for studies of virus dynamics. Thus PCR studies are seen as extending, not replacing, more conventional procedures.

### **Molecular epidemiology and topotyping**

Molecular epidemiology may be defined as the study of the relationship of an organism to other organisms on the basis of genomic analyses, for the purposes of recognising spatial and/or temporal differences or changes in populations.

Differences can be detected in the genomes of apparently similar viruses isolated from different geographical regions. For example, RNA-RNA hybridisation studies showed differences between BLU isolates from Australia and Africa (Huismans and Bremer 1981; Gorman et al. 1981). Similar results were obtained with RNA-recombinant DNA hybridisation (Gould 1988). Nucleotide sequencing of the gene segments being compared brought considerable analytical capability to these studies, and comparison of nucleotide sequences confirmed the differences among BLU isolates from different geographic regions (Gould 1987).

Similar studies have been conducted with other arboviruses. Isolates of St. Louis encephalitis virus were compared on the basis of oligonucleotide fingerprints: isolates could be grouped on the basis of similar fingerprints, and the different groups originated from different geographical areas within the USA. The term 'topotype' was used to refer to these groupings (Trent et al. 1981). Similar approaches have led to the description of topotypes of dengue virus serotype two in South East Asia (Trent et al. 1989).

Sequence analysis of BLU isolates, and comparison with known groups defined on the basis of sequence homology, again offers a new observational strategy for epidemiological studies. If the normal BLU 'topotype' has been determined at any location, the sequencing of new isolates will help confirm the stability of the virus-host ecosystem in that place, or, alternatively, detect new virus incursions into the area. If the sequence data of the new incursion show homology with another known grouping, an inference may be made about the possible source of the new viral incursion. Even if the new incursion is of a serotype that already occurs in the area, the difference in nucleotide sequence gives a marker for monitoring the spread of the introduced virus. This could have important practical benefits, for the introduced virus may be more pathogenic than existing strains, and hence be associated with an increased risk of disease in susceptible sheep.



For example, the Australian prototype isolates of the eight BLU serotypes so far identified may be grouped into two topotypes on the basis of sequence analysis of their viral RNA segment 3, with isolates within groups showing more than 95% sequence homology. Seven isolates, of BLU1, 3, 9, 16, 20, 21 and 23, group in one topotype while the prototype isolate of BLU15 has considerably less homology with the other isolates, and so must be considered in a different grouping (Gould 1987; Gould and Pritchard 1991). However, the sequence data of more recent Australian isolates identified viruses that did not group with those originally described (McCull et al. 1994; Melville and Hunt these Proceedings). Further research is needed to determine whether these newer isolates have sequence homology with viruses from other geographic regions, and whether they may be new incursions from such regions.

### **Basic Epidemiological Studies of Bluetongue Disease**

The approaches discussed above are applicable to the epidemiological study of bluetongue infections irrespective of whether such infections are associated with disease. The diagnosis of bluetongue disease in a country necessitates an extra dimension to epidemiological studies, to describe the impact of the disease on the susceptible sheep population. There is a need to ascertain the true incidence of disease morbidity and mortality, so that an assessment may be made of the economic cost to farmers and to the nation. Only on this basis will it be possible to estimate the cost-effectiveness of control measures.

There are three broad approaches to data collection, and the strengths and disadvantages of each have been evaluated critically by Daniels et al. (1993). The appropriate mix of approaches will depend on the veterinary infrastructure of the affected country, on the size of farms and on the social organisation of the farming systems. Assessing disease-associated losses in systems based on smallholder farmers living in villages, on nomadic herdsmen or on extensive pastoral holdings will require different adaptations of the basic principles.

Routine (passive) data may be available from veterinary field reports or laboratory records. However, such data often suffer from major biases associated with variables in reporting and specimen submission (Martin 1993). As with studies of infections, the most accurate data on disease occurrence will result from programs of structured surveillance (Morris and Leidl 1993), in which there is active monitoring for cases accompanied by accurate laboratory diagnosis. Such studies require considerable management inputs. An

alternative approach is to attempt farmers' local knowledge through various strategies of participative appraisal (Young 1993); this requires development of a consensus between investigators and farmers of an appropriate clinical case definition for use in on-farm interviews.

Another aspect of the study of bluetongue disease is confirmation of the relative pathogenicity of the bluetongue viruses present, through experimental infections of susceptible sheep. Virus pathogenicity is independent of serotype: BLU1 in South Africa is highly pathogenic (Gard 1987) while the first BLU1 in Australia is only mildly pathogenic (Hooper et al. 1996). To give confidence to the interpretation of epidemiological studies, pathogenicity should be confirmed experimentally. Although the marker or feature conferring pathogenicity to bluetongue viruses is not known, observations show that these viruses become attenuated after passage through cell culture (Gard 1987). Inocula for experimental studies must be viruses passaged only in ruminants. Comparative studies of viral pathogenicity should also standardise the age and breed of experimental sheep (Johnson et al. 1992; Sendow et al. these Proceedings).

### **A Regional Perspective**

Bluetongue viruses are vector-borne, and so cannot be contained or excluded by national boundaries, even when these are supported by efficient quarantine services. The epidemiology of bluetongue infections can be more easily understood with collaboration between neighbouring countries, or among countries within a geographical region. The sharing of technology and data will allow each participating country more fully to appreciate influences affecting its current situation, and challenges that may arise in the future.

Indonesia and Australia have developed such collaboration over several years (Daniels et al. 1996). Close similarities in the BLU fauna of both have been identified, with six serotypes BLU 1, 3, 9, 16, 21 and 23 occurring in each country (Melville and Hunt 1996; Sendow et al. these Proceedings). BLU7 and BLU12 have been isolated in Indonesia but not in northern Australia, while BLU15 and BLU20 have been isolated in northern Australia but not in Indonesia (Gard and Melville 1989). However, serological studies (Sendow et al. 1991) do show evidence of BLU20 in Indonesia. Further north, BLU1, 3, 9, 16 and 23 have also been isolated in Malaysia, where an additional serotype, BLU2, has also been reported (Sharifah et al. 1995). Such comparisons raise questions about whether the serotypes apparently restricted to one country at present will be found to be

more widely dispersed, and whether the viruses apparently common to two or more countries comprise part of more broadly distributed populations or whether they are separate foci of infection.

An important consideration in any region is the pathogenicity to sheep of the region's local and nearby bluetongue viruses. In the Southeast Asian and Australian region, naturally occurring bluetongue disease has been reported in both Indonesia and Malaysia in imported sheep, but not in local sheep also exposed to infection. In Australia, susceptible sheep are not usually exposed to BLU infections, being reared in the BLU-free zone. Pathogenicity tests in Indonesia (Sendow et al. these Proceedings) and Australia (Hooper et al. 1996) have shown that the strains tested in each country are of relatively low pathogenicity. Countries in this region should monitor for the introduction of more pathogenic strains.

Molecular epidemiological techniques, as described above, appear to offer a means of monitoring the distribution and movement of BLU strains within a region. For example, initially a definite regional grouping of Australian bluetongue viruses was observed (Gould 1987; Gould and Pritchard 1991; Pritchard et al. 1995). However, the latest observations show that some more recent isolates in northern Australia are genetically distinct from the prototype isolates (Melville and Hunt these Proceedings). Indonesian BLU isolates are distinct from the original Australian grouping, and furthermore do not comprise an homogenous group (Sendow et al. these Proceedings). Further analysis of the data from a regional perspective will attempt to identify broader groupings of isolates based on the degree of closeness of genetic relationships. Probable patterns of movement of virus strains may be identified, as may changes in the genetic composition of virus strains over time or in response to other epidemiological influences.

## Conclusion

Bluetongue viruses can cause severe disease in some sheep, but usually do not do so, nor do they cause disease in cattle, the main mammalian host. Bluetongue viruses are widely distributed in tropical and subtropical countries, frequently occurring as inapparent infections. Epidemiological investigations based on sentinel herd techniques allow isolations and other studies of all BLU infections, not just those associated with disease, and form the basis for further analyses of virus biology and epidemiology. Where bluetongue disease occurs, serious financial losses have been reported. Molecular studies show that strains of these vector-borne viruses can be highly mobile between geographical locations. Effective

monitoring for changes that may be associated with a higher risk of disease requires isolation and characterisation of bluetongue viruses.

## Acknowledgments

P.W. Daniels was supported in part by the Australian Exotic Animal Disease Preparedness Consultative Council (EXANDIS).

## References

- Cannon, R.M and Roe, R.T. 1982. Livestock disease surveys: a field manual for veterinarians. Australian Government Publishing Service, Canberra, 35 p.
- Daniels, P.W., Holden, S., Lewin, E. and Sri Dadi. ed. 1993. Livestock services for smallholders: a critical evaluation. Indonesia International Animal Science Research and Development Foundation, Bogor. 377 p.
- Daniels, P.W., Sendow, I., Soleha, E., Jennings, J. and Sukarsih. 1991. A veterinary arbovirus monitoring program. In: S.W. Martin, ed., Proceedings 6th Congress of the International Society for Veterinary Epidemiology and Economics (ISVEE). Ottawa, 207-209.
- Daniels, P.W., Sendow, I., Soleha, E., Sukarsih, Hunt, N.T. and Bahri, S. 1996. Australian-Indonesian collaboration in veterinary arbovirology. A review. *Veterinary Microbiology*.
- Della-Porta, A.J., Parsonson, I.M. and McPhee, D.A. 1985. Problems in the interpretation of diagnostic tests due to cross-reactions between orbiviruses and broad serological responses in animals. In: Barber, T.C., Jochim, M.S. and Osburn, B.I. ed., *Bluetongue and related orbiviruses*. Progress in Clinical and Biological Research, vol. 178, Alan R. Liss Inc., New York, 445-453.
- Della-Porta, A.J., Sellers, R.F., Hermiman, K.A.J., Littlejohns, I.R., Cybinski, D.H., St. George, T.D., McPhee, D.A., Snowdon, W.A., Campbell, J., Cargill, C., Corbould, A., Chung, Y.S. and Smith, V.W. 1983. Serological studies of Australian and Papua New Guinea cattle and Australian sheep for the presence of antibodies against bluetongue group viruses. *Veterinary Microbiology*, 8, 147-162.
- Erasmus, B.J. 1975a. The epizootiology of bluetongue: the African situation. *Australian Veterinary Journal*, 51, 196-198.
- 1975b. Bluetongue in sheep and goats. *Australian Veterinary Journal*, 51, 165-170.
- Gard, G.P. 1987. Studies of bluetongue virulence and pathogenesis in sheep. Technical Bulletin No. 103. Department of Industries and Development, Darwin, 58 p.
- Gard, G.P. and Melville, L.F. 1989. The evolution of bluetongue in Northern Australia. In: Uren, M.F., Blok, J. and Manderson, L.H. ed., *Arbovirus research in Australia*. Proceedings 5th Symposium. CSIRO/Queensland Institute of Medical Research, Brisbane, 303-305.
- 1992. Results of a decade's monitoring for orbiviruses in sentinel cattle pastured in an area of regular arbovirus activity in northern Australia. In: Walton, T.E. and Osburn, B.I., ed., *Bluetongue, African horse sickness and*

- related orbiviruses. Proceedings 2nd International Symposium. CRC Press, Boca Raton, 85–89.
- Gard, G.P., Weir, R.P. and Walsh, S.J. 1988. Arboviruses recovered from sentinel cattle using several virus isolation methods. *Veterinary Microbiology*, 18, 119–125.
- Gibbs, E.P.J. 1992. Epidemiology of orbiviruses Bluetongue: towards 2000 and the search for patterns. In: Walton, T.E. and Osburn, B.I., ed., *Bluetongue, African horse sickness and related orbiviruses*. Proceedings 2nd International Symposium. CRC Press, Boca Raton, 65–75.
- Gorman, B.M., Taylor, J., Walker, P.J., Davidson, W.L. and Brown, F. 1981. Comparison of bluetongue type 20 with certain viruses of the bluetongue and Eubenberg serological groups of orbiviruses. *Journal of General Virology*, 57, 251–261.
- Gould, A.R. 1987. The nucleotide sequence of bluetongue virus serotype 1 RNA 3 and a comparison with other geographic serotypes from Australia, South Africa, the United States of America and other orbivirus isolates. *Virus Research*, 7, 169–183.
- 1988. The use of recombinant DNA probes to group and type orbiviruses. A comparison of Australian and South African isolates. *Archives of Virology*, 99, 205–220.
- Gould, A.R. and Pritchard, L.I. 1991. Phylogenetic analyses of the complete nucleotide sequence of the capsid protein (VP3) of Australian epizootic haemorrhagic disease of deer virus (serotype 2) and cognate genes from other orbiviruses. *Virus Research*, 21, 1–18.
- Hooper, P.T., Lunt, R.A. and Stanislawek, W.L. 1996. A trial comparing the virulence of some South African and Australian bluetongue viruses. *Australian Veterinary Journal*, 73, 36–37.
- Huisman, H. and Bremer, C.W. 1981. A comparison of an Australian bluetongue virus isolate (CSIRO19) with other bluetongue virus serotypes by cross-hybridization and cross-immune precipitation. *Onderstepoort Journal of Veterinary Research*, 48, 59–67.
- Huisman, H. and Erasmus, B.J. 1981. Identification of the serotype-specific and group-specific antigens of bluetongue virus. *Onderstepoort Journal of Veterinary Research*, 48, 51–58.
- Johnson, S.J., Hoffmann, D., Flanagan, M., Polkinghorne, I.G. and Bellis, G.A. 1992. Clinico-pathology of Australian bluetongue virus serotypes for sheep. In: Walton, T.E. and Osburn, B.I., ed., *Bluetongue, African horse sickness and related orbiviruses*. Proceedings 2nd International Symposium. CRC Press, Boca Raton, 737–743.
- Lunt, R.A., White, J.R. and Blacksell, S.D. 1988. Evaluation of a monoclonal antibody blocking ELISA for the detection of group specific antibodies to bluetongue virus in experimental and field sera. *Journal of General Virology*, 69, 2729–2740.
- MacLachlan, N.J., Barratt-Boyes, S.M., Brewer, A.W. and Stott, J.L. 1992. Bluetongue virus infections of cattle. In: Walton, T.E. and Osburn, B.I., ed., *Bluetongue, African horse sickness and related orbiviruses*. Proceedings 2nd International Symposium. CRC Press, Boca Raton, 725–736.
- Martin, W. 1993. The analysis of routinely collected data. In: Daniels, P.W., Holden, S., Lewin, E. and Sri Dadi, ed., *Livestock services for smallholders: a critical evaluation*. Indonesia International Animal Science Research and Development Foundation, Bogor, 43–47.
- McColl, K.A. and Gould, A.R. 1991. Detection and characterisation of bluetongue virus using the polymerase chain reaction. *Virus Research*, 21, 19–34.
- McColl, K.A., Gould, A.R., Pritchard, L.I., Melville, L. and Bellis, G. 1994. Phylogenetic characterisation of bluetongue viruses from naturally-infected insects, cattle and sheep in Australia. *Australian Veterinary Journal*, 71, 102–105.
- Morris, R.S. and Leidl, K. 1993. Structured data collection for animal health and production in smallholder livestock production. In: Daniels, P.W., Holden, S., Lewin, E. and Sri Dadi, ed., *Livestock services for smallholders: a critical evaluation*. Indonesia International Animal Science Research and Development Foundation, Bogor, 69–77.
- Pritchard, L.I., Gould, A.R., Wilson, W.C., Thompson, L., Mertens, P.P.C. and Wade-Evans, A.M. 1995. Complete nucleotide sequence of RNA segment 3 of bluetongue serotype 2 (Ona-A). Phylogenetic analyses reveal the probable origin and relationship with other orbiviruses. *Virus Research*, 35, 247–261.
- Sendow, I., Daniels, P.W., Cybinski, D.H., Young, P.L. and Ronohardjo, P. 1991. Antibodies against certain bluetongue and epizootic haemorrhagic disease viral serotypes in Indonesian ruminants. *Veterinary Microbiology*, 28, 111–118.
- Sendow, I., Daniels, P.W., Soleha, E. and Sukarsih, 1992. Epidemiological studies of bluetongue viral infections in Indonesian livestock. In: Walton, T.E. and Osburn, B.I., ed., *Bluetongue, African horse sickness and related orbiviruses*. Proceedings 2nd International Symposium. CRC Press, Boca Raton, 147–154.
- Sendow, I., Young, P. and Ronohardjo, P. 1986. Preliminary survey for antibodies to bluetongue-group virus in Indonesian ruminants. *Veterinary Record*, 119, 603.
- Sharifah, S.H., Ali, M.A., Gard, G.P. and Polkinghorne, I.G. 1995. Isolation of multiple serotypes of bluetongue virus from sentinel livestock in Malaysia. *Tropical Animal Health and Production*, 27, 37–42.
- Standfast, H.A., Muller, M.J. and Dyce, A.L. 1992. An overview of bluetongue virus vector biology and ecology in the oriental and Australasian regions of the Western Pacific. In: Walton, T.E. and Osburn, B.I., ed., *Bluetongue, African horse sickness and related orbiviruses*. Proceedings 2nd International Symposium. CRC Press, Boca Raton, 253–261.
- St. George, T.D. 1979. The technology and application of sentinel herds and serum banks. In: Geering, W.A., Roe, R.T. and Chapman, L.A., ed., *Proceedings of the Second International Symposium on Veterinary Epidemiology and Economics*. Australian Government Publishing Service, Canberra, 69–75.
- 1980. A sentinel herd system for the study of arbovirus infections in Australia and Papua-New Guinea. *Veterinary Science Communications*, 4, 39–51.
- St. George, T.D., Cybinski, D.H., Della-Porta, A.J., McPhee, D.A., Wark, M.C. and Bainbridge, M.H. 1980. The isolation of two bluetongue viruses from healthy cattle in Australia. *Australian Veterinary Journal*, 56, 562–563.
- Sudana, I.G. and Malole, M., 1982. Penyidikan penyakit hewan bluetongue di desa Caringin, Kabupaten Bogor. In:

- Annual report of disease investigation in Indonesia during the period of 1975-1981, Direktorat Kesehatan Hewan, Direktorat Jenderal Peternakan, Jakarta, 110-121.
- Sukarsih, Daniels, P.W., Sendow, I. and Soleha, E., 1993. Longitudinal studies of *Culicoides* spp. associated with livestock in Indonesia. In: Uren, M.F. and Kay, B.H. ed., Arbovirus research in Australia. Proceedings 6th Symposium. CSIRO/Queensland Institute of Medical Research, Brisbane, 203-209.
- Trent, D.W., Grant, J.A., Monath, T.P., Manske, C.L., Corina, M. and Fox, G.A. 1989. Genetic variation and microevolution of dengue 2 virus in southeast Asia. *Virology*, 172, 523-535.
- Trent, D.W., Grant, J.A., Vorndam, A.D. and Monath, T.P. 1981. Genetic heterogeneity among Saint Louis encephalitis virus isolates of different geographic origin. *Virology*, 114, 319-332.
- Ward, M.P., Flanagan, M. and Baldock, F.C. 1995. Infection of cattle in Queensland with bluetongue viruses: 1. prevalence of antibodies. *Australian Veterinary Journal*, 72, 182-186.
- Young, J. 1993. Alternative approaches to the identification of smallholder problems and opportunities. In: Daniels, P.W., Holden, S., Lewin, E. and Sri Dadi, ed., Livestock services for smallholders: a critical evaluation. Indonesia International Animal Science Research and Development Foundation, Bogor, 123-130.
- Young, P.L., Hunt, N.T., Ibrahim, I., Sarosa, A., Darminto and Ronohardjo, P. 1985. Establishment of a national serum bank in Indonesia. In: Della-Porta, A.J., ed., Veterinary viral diseases: their significance in South East Asia and the Western Pacific. Academic Press, Orlando, 381-384.

# Entomology

## Introduction

THE epidemiology of an insect-borne virus disease such as bluetongue cannot be understood without a knowledge of its insect vectors. If we are to understand the dynamics of transmission, we must know which *Culicoides* species transmit the virus, their relationship to the vertebrate host and the efficiency with which different species transmit the different serotypes.

There is a similarity between the present situation in China and the situation in Australia in 1977 when bluetongue was first discovered there. In China, there are at least 73 known species of *Culicoides*, possibly a third of which feed on sheep and may be involved in the transmission of bluetongue virus. In Australia, at least 150 *Culicoides* species are known. These figures suggest that there are many more species in China waiting to be discovered. In Australia, we did not know which species transmitted the virus but suspected *C. marksii*, which was known to feed on sheep

and from which 40 isolations of an orbivirus had been made. However, when this species was tested by feeding it on infected sheep it did not become infected with bluetongue virus. However, several other *Culicoides* species were capable of being infected in this way.

So one lesson to be drawn from the Australian experience is that all species of *Culicoides* that feed on sheep and cattle must be tested for ability to transmit the virus. Another lesson is that the species of *Culicoides* able to be infected had different susceptibilities to different serotypes, and individual species transmitted different serotypes with varying efficiency.

Hence, the emphasis of the Symposium's Entomology Workshop was on simple techniques to answer the question 'What species of *Culicoides* transmit bluetongue, and how efficiently do they transmit it?'

# *Culicoides* Survey in Indonesia

Sukarsih\*, I. Sendow\*, S. Bahri\*, M. Pearce<sup>†</sup> and P.W. Daniels<sup>§</sup>

## Abstract

*Culicoides* were collected by light traps at sites adjacent to livestock, especially penned cattle. The areas surveyed were West Java (Depok and Cisarua), Bali, Nusa Tenggara Timur (Kupang) and Irian Jaya (Jayapura and Merauke). The survey sought to identify *Culicoides* species found in those areas and to isolate bluetongue virus from *Culicoides*. The most abundant species in Irian Jaya and Bali was *C. peregrinus*; in Nusa Tenggara Timur *C. oxystoma*; in Cisarua *C. parahumeralis*; and in Depok *C. sumatrae*. *Culicoides brevitarsis* and *C. fulvus*, species reported as vectors of bluetongue virus, were found at all surveyed locations, while another vector, *C. actoni*, was found in Irian Jaya and Java but not in Kupang or Bali. *Culicoides orientalis*, which is closely related to vector species, was also found at all locations. Bluetongue virus (BLU) serotype 21 was isolated from a pool of *C. fulvus* and *C. orientalis*.

MANY haematophagous insects are of economic importance because they transmit disease. Kettle (1984) reported the importance of *Culicoides* midges in the transmission of disease organisms to humans and animals. Among the more important viruses for which *Culicoides* are vectors is the bluetongue virus (BLU), which has a global distribution involving Africa, Asia, Australia and North and Central America. Epidemiological observations have shown that, although bluetongue infections are endemic in tropical areas of the world such as Indonesia, there is no associated disease in populations of local sheep (Sendow et al. 1989, 1992). However, as bluetongue disease has been reported in imported sheep in Indonesia

(Sudana and Malole 1982), the virus is important in the context of its potential impacts on trade and development programs.

Implication of any insect species as an arbovirus vector is a multistep process. The insect must be known to feed on the mammalian host and the virus must be isolated from the insect in nature. Experimental studies should also show that the insect is able to transmit the virus biologically among mammalian hosts. In Indonesia BLU serotype 21 has been isolated from a mixed pool of *C. fulvus* and *C. orientalis* of the subgenus *Avaritia* (Sendow et al. 1993). The transmission of bluetongue viruses by *C. fulvus*, *C. wadai*, *C. actoni*, and *C. brevitarsis* has been reported in Australia, which neighbours Indonesia (Standfast et al. 1985). These species may therefore be considered potential vectors in Indonesia.

As a first step in determining bluetongue vectors in Indonesia, surveys have determined the range of *Culicoides* species present in major livestock-producing areas. While some results have been presented previously (Sukarsih et al. 1993), this paper presents additional data on the *Culicoides* species found in some areas of Indonesia, and recommends further avenues for investigation.

\* Research Institute for Veterinary Science, PO Box 52, Bogor, Indonesia.

<sup>†</sup> Indonesia International Animal Science Research and Development Foundation (INI ANSREDEF), PO Box 1093, Bogor 16010, Indonesia

<sup>§</sup> Department of Primary Industry and Fisheries, Berrimah Agricultural Research Centre, PO Box 79, Berrimah, Darwin, Northern Territory 0828, Australia

## Materials and Methods

### Collection sites

Collections were made adjacent to sentinel groups of cattle which were monitored separately for serology and virus isolation (Sendow et al. 1989, 1992). These sentinel groups were at sites located strategically across the length of Indonesia, including West Java (Depok and Cisarua), Bali (Denpasar), Nusa Tenggara Timur province (Kupang on West Timor, and Rote Island) and Irian Jaya (Jayapura, Merauke, Wamena, Timika and Biak). Other collections were made from some farming areas in Central Java (Semarang), Lampung province and South Kalimantan (Banjarbaru).

### Collection and processing procedures

In Bali, Lampung and Banjarbaru, battery-powered, modified Centers for Disease Control (CDC) light traps were used, whereas in West Timor, Rote and Irian Jaya battery-powered, modified CDC light traps and Pirbright-type miniature light traps were used. The traps were sited adjacent to livestock, especially penned cattle, and also adjacent to standing surface water where possible. Traps were set in the late afternoon and allowed to run until daybreak. In West Java and Central Java insects were collected with Pirbright-type miniature light traps operated from the mains supply via a 12 volt step-down transformer. Collections were made from 4.30 pm to 8.00 pm. At sentinel sites collections were made once a week throughout the year, while at Wamena, Timika, Biak and Rote Island they were made monthly. At Lampung, Central Java and Banjarbaru collections were made during a single sampling expedition. The catches were held in 70% alcohol, except in West Java where, since virus isolation was to be attempted, the insects were blown directly into a bottle containing phosphate buffered saline (PBS) supplemented with antibiotics and containing 0.1% detergent.

The catches from each location were sorted in the laboratory under a binocular microscope. From catches in West Java, the female *Culicoides* were sorted to species and parous females separated on the basis of abdominal pigmentation (parous adults were distinguished by the development of dark red pigment in the epidermal or subepidermal layers of the abdomen; Dyce 1969). *Culicoides* identification was based on standard texts (Dyce unpublished; Ratanaworabhan 1975; Tokunaga 1959; Wirth and Hubert 1989). Numbers of each species for every trapping were recorded.

Insects difficult to identify were mounted for independent confirmation by A.L. Dyce. Mounted specimens were prepared by serial washing in graded alcohols (70%, 80%, 90% and absolute) followed by clearing in creosote, and mounted in thin xylol-balsam.

## Results

### Lampung (Sumatra)

*Culicoides* were collected from three locations in Lampung, with nine species recorded (Table 1). The dominant species was *C. orientalis*, followed by *C. sumatrae* and *C. peregrinus*. Vector species *C. actoni* and *C. fulvus* were also present.

**Table 1.** Species of *Culicoides* collected in Lampung, Banjarbaru and Central Java.

Species	Lampung	Banjarbaru	Central Java
<i>C. actoni</i>	28	32	7
<i>C. arakawae</i>	30	5	4
<i>C. barnetti</i>	10	3	10
<i>C. fulvus</i>	7	9	2
<i>C. geminus</i>	29	9	1
<i>C. guttifer</i>	10	1	5
<i>C. orientalis</i>	74	95	58
<i>C. oxystoma</i>	11	57	86
<i>C. parahumeralis</i>	29	5	10
<i>C. peregrinus</i>	39	123	180
<i>C. sumatrae</i>	51	76	3

### Banjarbaru (South Kalimantan)

Eleven species were collected from two locations in Banjarbaru (Table 1). The dominant species was *C. peregrinus* followed by *C. orientalis* and *C. sumatrae*. Vector species *C. actoni* and *C. fulvus* were again present.

### Central Java

Two locations at Semarang were sampled, yielding nine species. The most abundant was *C. peregrinus*, followed by *C. oxystoma* (Table 1). Again *C. actoni* and *C. fulvus* were the only recognised vector species present.

### West Java

*Culicoides* collected at sentinel sites included 24 species at Depok and 22 species at Cisarua (Table 2). At Depok, *C. actoni* was the dominant species, followed by *C. parahumeralis*, *C. sumatrae*, *C. fulvus* and others. At Cisarua, *C. parahumeralis* was the dominant species, followed by *C. maculatus* and *C. orientalis*. The vector species *C. wadai* was present at Depok.

### Bali

At Denpasar 17 *Culicoides* species were collected (Table 3). By far the most abundant was *C. peregrinus*.



nus, followed by *C. oxystoma*, *C. arakawae*, *C. brevitarsis* and *C. fulvus*.

### Kupang, West Timor

At Kupang 23 species were collected (Table 3). *Culicoides oxystoma* predominated, with *C. brevitarsis*, *C. histrio*, *C. peregrinus* and *C. geminus* also well represented in collections, and *C. fulvus* and *C. wadai* present in smaller numbers.

**Table 2.** Species of *Culicoides* collected in Depok and Cisarua, West Java from October 1992 to September 1993.

Species	Depok	Cisarua
<i>C. actoni</i>	5870	16
<i>C. anophelis</i>	24	-
<i>C. arakawae</i>	8	-
<i>C. barnetti</i>	92	4
<i>C. fulvus</i>	1401	139
<i>C. geminus</i>	41	1
<i>C. gewertzi</i>	18	1
<i>C. guttifer</i>	21	4
<i>C. huffi</i>	16	3
<i>C. insignipennis</i>	40	90
<i>C. jacobsoni</i>	18	76
<i>C. liui</i>	1	57
<i>C. maculatus</i>	14	375
<i>C. orientalis</i>	809	154
<i>C. oxystoma</i>	681	9
<i>C. palpifer</i>	1173	125
<i>C. parahumeralis</i>	4523	838
<i>C. peregrinus</i>	957	11
<i>C. shortii</i>	371	1
<i>C. sumatrae</i>	2091	132
<i>C. wadai</i>	3	-
<b>Total</b>	<b>18172</b>	<b>2036</b>

### Rote Island

During this survey on Rote Island, *C. brevitarsis* was the most abundant species among the 11 species collected (Table 3), followed by *C. oxystoma*, *C. peregrinus* and *C. wadai*. *Culicoides fulvus* was also present.

### Irian Jaya

At the sentinel cattle site in Jayapura, 30 species of *Culicoides* were collected (Table 4), with *C. peregrinus* the most abundant and *C. brevitarsis* the

second most abundant. All four known vector species were present. In Merauke, *C. peregrinus* was again the most abundant among the 20 species collected (Table 4), followed by *C. brevitarsis*, *C. orientalis* and *C. histrio*, with all four vectors present. At the remaining Irian Jaya sites fewer insects were trapped. Among the 13 species collected at Biak, *C. peregrinus* was predominant, with *C. brevitarsis* and *C. fulvus* also present. (Table 4). Of the six species collected at Wamena, *C. maculatus* was the most abundant, followed by *C. peregrinus* (Table 4), and *C. wadai* was also present. At Timika 12 *Culicoides* species were collected (Table 4) including *C. brevitarsis*, *C. fulvus* and *C. wadai*.

**Table 3.** Species of *Culicoides* collected in Denpasar, Kupang and Rote Island in South East Indonesia.

Species	Denpasar	Kupang	Rote Island
<i>C. albibasis</i>	-	7	-
<i>C. anophelis</i>	12	-	-
<i>C. arakawae</i>	73	33	8
<i>C. barnetti</i>	9	23	28
<i>C. brevipalpis</i>	-	20	-
<i>C. brevitarsis</i>	51	936	189
<i>C. clavipalpis</i>	4	-	-
<i>C. effusus</i>	5	31	-
<i>C. flavescens</i>	-	5	-
<i>C. fulvus</i>	26	38	19
<i>C. geminus</i>	7	409	-
<i>C. gewertzi</i>	-	12	-
<i>C. guttifer</i>	17	19	-
<i>C. histrio</i>	-	739	-
<i>C. huffi</i>	19	-	-
<i>C. nudipalpis</i>	11	3	3
<i>C. orientalis</i>	23	26	-
<i>C. ornatus</i>	-	-	2
<i>C. oxystoma</i>	97	2983	95
<i>C. palpifer</i>	5	8	-
<i>C. pangkorensis</i>	-	19	-
<i>C. papuensis</i>	-	7	-
<i>C. parahumeralis</i>	14	17	-
<i>C. peliliouensis</i>	-	3	-
<i>C. peregrinus</i>	1675	642	67
<i>C. semicircum</i>	5	-	-
<i>C. sumatrae</i>	-	45	10
<i>C. wadai</i>	-	33	59

**Table 4.** Species of *Culicoides* collected in Irian Jaya: Jayapura, Merauke, Biak, Wamena and Timika.

Species	Jayapura	Merauke	Biak	Wamena	Timika
<i>C. actoni</i>	12	9	–	–	–
<i>C. arakawae</i>	–	–	–	–	–
<i>C. ardleyi</i>	65	–	–	–	–
<i>C. austropalpalis</i>	2	5	–	–	–
<i>C. barnetti</i>	21	–	8	–	–
<i>C. brevitarsis</i>	895	215	10	–	9
<i>C. dumdumi</i>	4	–	–	–	–
<i>C. effusus</i>	14	–	3	–	5
<i>C. fulvus</i>	56	21	12	–	11
<i>C. gemellus</i>	8	12	–	–	–
<i>C. geminus</i>	–	–	–	–	–
<i>C. gewertzi</i>	31	–	–	–	–
<i>C. guttifer</i>	38	–	4	–	12
<i>C. histrio</i>	27	–	5	–	–
<i>C. huberti</i>	18	–	–	–	–
<i>C. jacobsoni</i>	15	37	–	–	–
<i>C. maculatus</i>	9	8	8	17	–
<i>C. neomelanesiae</i>	58	–	–	–	–
<i>C. nudipalpis</i>	19	2	–	–	2
<i>C. orientalis</i>	48	67	–	4	18
<i>C. ornatus</i>	2	7	–	–	–
<i>C. oxystoma</i>	7	98	13	6	27
<i>C. palpifer</i>	33	–	6	–	8
<i>C. pampangensis</i>	–	–	–	–	–
<i>C. pangkorensis</i>	174	5	–	–	–
<i>C. parabarnetti</i>	19	–	–	–	–
<i>C. parabubalus</i>	5	–	–	–	–
<i>C. parahumeralis</i>	42	–	23	–	41
<i>C. peliliouensis</i>	–	11	3	–	–
<i>C. peregrinus</i>	2013	1002	–	15	103
<i>C. petersi</i>	2	–	–	–	–
<i>C. pseudostigmatus</i>	4	9	–	2	–
<i>C. pungens</i>	–	3	–	–	–
<i>C. semicircum</i>	7	6	1	–	–
<i>C. sumatrae</i>	5	12	45	–	13
<i>C. wadai</i>	83	36	–	6	21

## Discussion

This paper reports on a component of a major longitudinal study of *Culicoides* species in Indonesia, previous results of which have been reported by Sukarsih et al. (1993). As the present results complement the earlier ones, without duplication, they offer an opportunity to identify trends. In the absence to date of any specific vector competence work in Indonesia, atten-

tion has focused on species shown to be vectors in neighbouring Australia (Standfast et al. 1985).

Sukarsih et al. (1993) reported on collections from Depok, Cisarua, Denpasar, Kupang, Jayapura and Merauke. Two of the four known vector species, *C. fulvus* and *C. brevitarsis*, were identified at all sites in that study; *C. wadai* was absent from only one site (Denpasar); and *C. actoni* was only absent from Kupang and Denpasar. Sukarsih et al. (1993) thus

noted that all four vector species were distributed widely in both western and eastern Indonesia.

Also in the first period of the study, *C. brevitarsis* had been among the more abundant species in the east, but not in the west (Sukarsih et al. 1993). An unexpected finding in this second period was the failure to identify *C. brevitarsis* at a majority of sites in western Indonesia, including all three survey sites in Sumatra, South Kalimantan and Central Java, and the regularly monitored sentinel sites at Depok and Cisarua in West Java. However, *C. brevitarsis* was detected at most sites from Bali eastward, with the exception of the high altitude site at Wamena, and was the second most abundant species trapped at Jayapura, Merauke and Kupang, confirming a trend. (Although numbers of *Culicoides* in light trap collections need not necessarily correlate with the size of the natural population at sampling sites, such data are the only basis currently available in Indonesia on which to compare the abundance of the various species.)

During both survey periods, *C. fulvus* was abundant in collections from Depok and Cisarua, and was widely distributed throughout Indonesia. As the species with the highest identified infection rates for BLU viruses in Australia (Standfast et al. 1985), *C. fulvus* is viewed as a most important vector in that country (Daniels and Melville 1996). We strongly recommend further studies of the role of this species as a vector.

Sukarsih et al. (1993) reported that, although *C. actoni* was abundant at Depok, it was not among the ten most abundant species at any of the collection sites in eastern Indonesia. The present results confirm those observations, with *C. actoni* again being the most abundant species at Depok, but not represented in collections from Denpasar and Kupang, and with only a few individuals trapped in Irian Jaya. This species was present at each of the sites surveyed in Sumatra, Kalimantan and Central Java, confirming a wide distribution. The breeding site for this species is associated with vegetation (Wirth and Hubert 1989), a factor which may be associated with apparently low numbers in some areas.

In the first survey period, *C. wadai* appeared not to be present in large numbers, and was more frequently identified in Irian Jaya than elsewhere (Sukarsih et al. 1993). During the second period, only three insects of this species were trapped in western Indonesia, at Depok.

As the four vector species are all of the subgenus *Avaritia* (Wirth and Hubert 1989), Sukarsih et al. (1993) drew attention to the relative abundance and distribution of other members of this subgenus that should be tested for vector competence in Indonesia. *Culicoides brevipalpis* supports BLU growth, as do a range of other *Culicoides* species (Standfast et al.

1985), but has not been studied sufficiently to confirm or deny its vector status, and has been identified in Indonesia only in low numbers. *Culicoides orientalis* and *C. nudipalpis* both feed on cattle and have been trapped in relative abundance, particularly in the case of *C. orientalis* in western Indonesia. As *C. orientalis* comprised 20% of a pool of *Avaritia* subgenus midges from which BLU21 was isolated in West Java (Sendow et al. 1993), more specific studies of the vector potential of this species are considered important.

In both this survey period and that reported by Sukarsih et al. (1993), considerable numbers of *C. fulvus* were identified at Cisarua, where the species was respectively the second and fourth most abundant *Culicoides* in collections during the two reporting periods. Cisarua is a high altitude site 1300 m above sea level in West Java, some 75 km or more inland, with an average annual rainfall of 3500 mm. In Australia, *C. fulvus* has been trapped mostly in coastal areas in the far north (Johnson 1992). The larval habitat of *C. fulvus* is unknown (Wirth and Hubert 1989) although it is probably an important vector species, as suggested by its high experimental infection rates (Standfast et al. 1985) and its wide distribution and abundance in both Indonesia and northern Australia at sites with a high incidence of BLU infections (Daniels and Melville 1996). Further studies to identify the breeding and other habitat requirements of this species seem essential to a full understanding of bluetongue epidemiology in the Southeast Asian and Australian region.

## Acknowledgments

A.L. Dyce assisted with insect identification. Dr Bahri helped process specimens. The Australian Quarantine and Inspection Service gave support under the Northern Australian Quarantine Strategy.

## References

- Daniels, P.W. and Melville, L. 1996. Arboviruses of livestock in the Northern Territory. CSIRO/Northern Territory Department of Primary Industry and Fisheries.
- Dyce, A.L. unpublished. Atlas of Wing Pictures of the *Culicoides* from the Australian Region (Draft). 50 p.
- 1969. The recognition of nulliparous and parous *Culicoides* (Diptera: Ceratopogonidae) without dissection. Journal Australian Entomological Society, 8, 11–15.
- Johnson, S. 1992. The distribution of vectors of arboviruses of livestock in Northern Australia. Final Report Project DAQ68. Department of Primary Industries, Townsville.
- Kettle, D.S. 1984. Medical and Veterinary Entomology. Croom Helm, London and Sydney, 157 p.
- Ratanaworabhan. 1975. An illustrated key to the female *Culicoides* of the Chiangmai Valley, Thailand. United

- States Navy Medical Component, South East Treaty Organization, Bangkok. 49 p.
- Sendow, I., Daniels, P.W., Soleha, E., Hunt, N., Bale, A. and Ronohardjo, P. 1989. Studies on orbiviral infections of sentinel ruminants in Indonesia. In: Uren, M.F., Blok, J. and Manderson, L.H. ed., Arbovirus research in Australia, Proceedings 5th Symposium. CSIRO/Queensland Institute of Medical Research, Brisbane, 311-315.
- Sendow, I., Daniels, P.W., Soleha, E. and Sukarsih 1992. Epidemiological studies of bluetongue viral infections in Indonesian livestock. In: Walton, T.E. and Osburn, B.I., ed., Bluetongue, African horse sickness and related orbiviruses. Proceedings 2nd International Symposium. CRC Press, Boca Raton, 147-154.
- Sendow, I., Sukarsih, Soleha, E., Erasmus, B.J. and Daniels, P.W. 1993. Isolation of bluetongue virus serotype 21 from *Culicoides* spp. in Indonesia. *Veterinary Microbiology*, 36, 349-353.
- Standfast, H.A., Dyce, A. L. and Muller, M.J. 1985. Vectors of bluetongue in Australia. In: Barber, T.C., Jochim, M.S. and Osburn, B.I. ed., Bluetongue and related orbiviruses. Progress in Clinical and Biological Research, vol. 178, Alan R. Liss Inc, New York, 177-186.
- Sudana, I.G., and Malole, M. 1982. Penyidikan penyakit hewan bluetongue di desa Caringin, Kabupaten Bogor. In: Annual Report of Disease Investigation in Indonesia during the Period of 1975-1981, Direktorat Kesehatan Hewan, Direktorat Jenderal Peternakan, Jakarta, 110-121.
- Sukarsih, Daniels, P.W., Sendow, I., and Soleha, E. 1993. Longitudinal studies of *Culicoides* spp associated with livestock in Indonesia. In: Uren, M.F. and Kay, B.H. ed., Arbovirus research in Australia. Proceedings 6th Symposium. CSIRO/Queensland Institute of Medical Research, Brisbane, 203-209.
- Tokunaga, M. 1959. New Guinea biting midges. *Pacific Insects* 1, 2-3, 177-313.
- Wirth, W.W. and Hubert, A.A. 1989. The *Culicoides* of Southeast Asia (Diptera: Ceratopogonidae). American Entomological Institute, Gainesville, 508 p.

# Preliminary Results of Trapping for *Culicoides* in South China: Future Bluetongue Vector Studies

M.J. Muller\* and Li Huachun†

## Abstract

Since the first isolation of bluetongue virus in China, clinical disease has been seen in four provinces, and bluetongue antibodies reported in sheep and cattle in 29 provinces. Biting midges, *Culicoides* spp., are the recognised vectors of bluetongue, and at least 30 species have been reported from southern China. However, little is known about which species feed on livestock or which may be the important vectors of bluetongue or other livestock arboviruses. This paper reports on the *Culicoides* species taken in preliminary surveys with light traps near livestock in Yunnan and Sichuan Provinces. Future plans are suggested, based on experience with bluetongue epidemiology in Australia. Bluetongue vector studies in China will need to use bait collections, and further light trap and, if possible, truck trap collections. These studies should follow a regular collection routine to show seasonality and abundance of different species. Potential breeding sites, particularly cattle dung, can be examined to determine basic associations. In the longer term, species found to be closely associated with livestock can be tested in the laboratory for their vector competence with bluetongue viruses. This would include feeding on virus either in vivo or in vitro. Suspected vector species can then be inoculated and tested for their capacity to transmit virus to animals or to excrete virus, using *in vitro* techniques. Knowledge of vectors is required for any attempt to control or reduce incidence of bluetongue disease. These studies should determine which species are the important vectors of bluetongue viruses in China.

*CULICOIDES* biting midges are small flies found in tropical to temperate regions on every continent. Many species have reputations as pests because of their highly irritating bite. However, they have a potentially more damaging role as they can carry and transmit several viruses associated with livestock. The most important of these are the bluetongue viruses (BLU). These infect ruminants and can cause severe disease and mortality in sheep, thus disrupting international trade in ruminants and their germplasm.

Bluetongue was first recognised in China in 1979 (Zhang Nianzu et al. 1989), and, on the basis of clinical disease and/or antibody assessments, has since been reported in many of China's provinces and autonomous regions.

The recognition of bluetongue virus in China has focused attention on the *Culicoides* species of China. This paper provides some background on those species, and examines relevant vector competence studies in other countries. We also suggest how to proceed with such studies in China.

There are 24 BLU serotypes recognised around the world, with a small number of known vectors and many other potential vectors. Wirth and Dyce (1985) grouped enzootic bluetongue areas into three north-south zones, each with its own set of vectors cycling viruses which themselves seemed to fall into distinct groups. These three zones were Africa and the Mediterranean; Australia and eastern Asia; and the Americas. The most important BLU vectors in each zone

\* CSIRO Division of Tropical Animal Production, Long Pocket Laboratories, Private Bag No 3 PO, Indooroopilly, Queensland 4068, Australia (present address: Brisbane City Council, Vector Services, 145 Sydney Street, New Farm, Queensland 4055, Australia).

† Yunnan Tropical and Subtropical Animal Virus Diseases Laboratory, Jindian 650224, Kunming, People's Republic of China.

tend to be part of species groups with close taxonomic relatives that are difficult to separate.

In Africa and the Mediterranean, *C. pallidipennis*, a member of the subgenus *Avaritia*, was originally described as the vector of bluetongue. It was later realised that this species was a synonym of *C. imicola*, which itself can be readily confused with several species (Meiswinkel 1989). Similar problems exist with the *schultzei* group, another batch of potential bluetongue vectors. This species name was used by early workers but '*C. schultzei*' it is now recognised as a mixture of species.

In Australia and Southeast Asia, the taxonomic problems are similar to those in Africa, in that the subgenus *Avaritia* and the *schultzei* group are involved. However, the members of these groups are different from their African counterparts. In this region, the most common species in the *schultzei* group is *C. oxystoma*, and reference is often made to the *schultzei/oxystoma* group. In Australia, the unmasking of the species that could be infected with BLU was only possible because of detailed taxonomic studies by Alan Dyce (Dyce and Standfast 1979; Dyce 1982, 1989). Before these studies, all four potential vectors in the subgenus *Avaritia* were lumped together as *C. brevitarsis*. Subsequently, the original *C. brevitarsis* was identified as including *C. actoni*, *C. fulvus* and *C. wadai*. These four species have such different life cycles and vector competence rates for bluetongue that understanding the epidemiology of the virus in Australia would have been impossible without differentiating among these species. The subgenus *Avaritia* contains many very similar species across the Australasian and Oriental regions, and published descriptions could best be described as having been in a state of chaos until Alan Dyce was able to unravel much of the confusion (Dyce 1979, 1980, 1983; Dyce and Wirth 1983).

In the Americas, the taxonomic problems revolve around different *Culicoides* species. Identified as a BLU vector in the 1950s, *C. variipennis* is now considered to be a complex of subspecies of varying vector competence (Wirth and Morris 1985; Tabachnik 1992). A member of the subgenus *Monoculicoides*, '*C. variipennis*' has close relatives in Africa, Europe and Asia. None of these relatives have yet been implicated in natural BLU transmission, although some have been infected experimentally (Jennings and Mellor 1988). In Florida, BLU has been isolated from *C. insignis*, in areas where the virus is active in cattle but *C. variipennis* is not found (Greiner et al. 1985). Now confirmed as a vector in Florida, *C. insignis* is probably also a vector in the Caribbean and in South America (Tanya et al. 1992).

Clearly accurate taxonomy of vectors is an absolute prerequisite for unravelling the epidemiology of an arbovirus. Morphologically similar species and

members of the same subgenus commonly have very different vector competences. Perhaps the best example is the group of four Australian BLU vectors *C. actoni*, *C. brevitarsis*, *C. fulvus* and *C. wadai*: though extremely similar in appearance, all have very different distributions, breeding sites and vector competence for BLU (Standfast et al. 1985).

Also in any epidemiological studies it is essential to keep good quality specimens, properly prepared and preserved. In the case of *Culicoides*, this means slide-mounted material. One of the problems with unravelling the *schultzei/oxystoma* group in particular is the loss, or poor quality, of type specimens available for study. Techniques for mounting small flies have been described (Steffan 1983; Wirth and Marston 1968); other unpublished methods are available from the authors. Producing good slide-mounted material is a combination of art and skill and requires much practice.

The *Culicoides* species reported as being present in China, and any known host associations of those species, are a starting point to which further information can be added (Table 1). Further synonyms may need to be determined, as well as some rearrangement of species names (Table 2). For example, one species is reported as *C. marginalis* Chu and Liu (Table 1), but this species must be renamed as the name already exists for an Australian species described by Lee and Reye (1962). Standfast et al. (1992) tabulated synonyms and confusion for three potential bluetongue vectors in the Oriental region (Table 3).

How do we approach these vector studies? Some of this work, such as that by Dr Weihai Zhou and his group in Anhui, is described elsewhere in these Proceedings. In Kunming, insect collections are being made. In both these places the importance of entomology studies is understood. However it is useful to look at our experience in Australia to make some pertinent points about studies of BLU vectors.

## Field Investigations

The first step is to determine which *Culicoides* species are associated with, and feed on, ruminants in areas where bluetongue virus is active, and to investigate the activity patterns of these species. Several techniques can be used for this, each with advantages and disadvantages.

### Light traps and truck traps

Light traps have many advantages. They do not require intensive labour, as traps can be set adjacent to livestock and left overnight. They can be set and cleared by operators who have had only minimal training.

Table 1. *Culicoides* species reported as being present in China.

Species	Reference	Host associations
<i>C. actoni</i> Smith	2, 4, 5, 6	human, livestock, marsupials
<i>C. albifascia</i> Tokunaga	4	
<i>C. alexandrae</i> Dzhafarov	7	
<i>C. amamiensis</i> Tokunaga (= <i>sumatrae</i> Macfie)	2, 3, 4	human
<i>C. anophelis</i> Edwards	2, 3	mosquitoes
<i>C. arakawae</i> (Arakawa)	2, 3, 5, 6	birds
<i>C. aterinervis</i> Tokunaga	1, 2, 4	
<i>C. buckleyi</i> Macfie (= <i>jacobsoni</i> Macfie)	4	
<i>C. chiopterus</i> Meigen	4	cattle, horse (dung breeder)
<i>C. circumscriptus</i> Kieffer	2, 3, 4	
<i>C. caucasicus</i>	7	
<i>C. clavipalpis</i> Mukerji	2	
<i>C. crairi</i> Kono and Takahashi	2	
<i>C. dubius</i> Arnaud	2	
<i>C. duodenarius</i> Kieffer	2	
<i>C. elbeli</i> Wirth and Hubert	3	
<i>C. elongatus</i> Chu and Liu	3	
<i>C. flavescens</i> Macfie	2, 3	
<i>C. flaviscutatus</i> Wirth and Hubert	2, 4	
<i>C. fukienensis</i> Chen and Tsai	2	human
<i>C. fulvus</i> Sen and Das Gupta	8	cattle
<i>C. gemellus</i> Macfie	2	
<i>C. grisescens</i> Edwards	4	
<i>C. hamiensis</i>	7	
<i>C. homotomus</i> Kieffer	2, 3, 4, 5, 6	human, cattle, buffalo, pig, sheep
<i>C. hui</i> Wirth and Hubert	2, 3	
<i>C. humeralis</i> Okada	2, 3, 4	
<i>C. imicola</i> Kieffer	8	cattle, sheep, horse
<i>C. jacobsoni</i> Macfie	2, 3, 4	
<i>C. kelinensis</i> Lee	4	
<i>C. kibunensis</i> Tokunaga	4	
<i>C. kureksthaticus</i> Dzhafarov	4	
<i>C. lasaensis</i> Lee	4	
<i>C. liui</i> Wirth and Hubert	3	
<i>C. longiporus</i> Chu and Liu	3	
<i>C. lungchiensis</i> Chen and Tsai	2	
<i>C. macfieii</i> Causey	3	
<i>C. maculatus</i> Shiraki	2, 4, 6	
<i>C. majorinus</i> Chu	1	
<i>C. malayae</i> Macfie	2	
<i>C. mamaensis</i> Lee	4	
<i>C. marginalis</i> Chu and Liu	3	
<i>C. matsuzawai</i> Tokunaga	2, 6	
<i>C. menglaensis</i> Chu and Liu	3	

Table 1. *Culicoides* species reported as being present in China.

Species	Reference	Host associations
<i>C. miharai</i> Kinoshita	2	human
<i>C. mihensis</i> Arnaud (= <i>morisitai</i> Tokunaga)	5	
<i>C. morisitai</i> Tokunaga	2	
<i>C. motoensis</i> Lee	4	
<i>C. nagarzensis</i> Lee	4	
<i>C. nipponensis</i> Tokunaga	2, 3, 4, 5	cattle, buffalo, sheep, goat, ass, pig
<i>C. obsoletus</i> (Meigen)	1, 4	cattle, sheep, goats, man
<i>C. okumensis</i> Arnaud (= <i>actoni</i> Smith)	3	
<i>C. orientalis</i> Macfie	4	
<i>C. palpifer</i> Das Gupta and Ghosh	2, 3, 4	
<i>C. paraflavescens</i> Wirth and Hubert	2, 3	
<i>C. peregrinus</i> Kieffer	2, 3	cattle, buffalo, horse
<i>C. pseudosalinarius</i> Chu	2	
<i>C. pulicaris</i> Linnaeus	4	cattle, sheep, horse, human
<i>C. punctatus</i> Meigen	2	
<i>C. qabdoensis</i> Lee	4	
<i>C. saevus</i> Kieffer	3	
<i>C. schultzei</i> (Enderlein)/ <i>oxystoma</i> Kieffer	2, 3, 5	buffalo, cattle, pig sheep goat, ass
<i>C. sigaensis</i> Tokunaga (= <i>maculatus</i> Shiraki)	3	
<i>C. similis</i> Carter, Ingram and Macfie	2	
<i>C. sinanoensis</i> Tokunaga	9	
<i>C. singkianensis</i>	7	
<i>C. spinulosus</i> Chu	1	
<i>C. subfascipennis</i> Kieffer	4	
<i>C. sumatrae</i> Macfie	2	
<i>C. suzukii</i> Kitaoka	8	
<i>C. tbilisicus</i> Dzhafarov	4	
<i>C. tentorius</i> Austen	4	
<i>C. tianmushenensis</i> Chu	2	
<i>C. tibetensis</i> Chu	1, 4	
<i>C. verbosus</i> Tokunaga	2	
<i>C. yunanensis</i> Chu and Liu	3	
<i>C. vexans</i> Staeger	4	

References

1. Chu Feng-I 1977
2. Chu Feng-I 1981
3. Chu Feng-I and Liu Shu-chung 1978
4. Lee Tie-sheng 1979
5. Su Genyuan and Zhou Weihuan 1992
6. Zhou Weihuan et al. 1991
7. Qin Qiying et al. these Proceedings
8. Li Huachun & Miller unpublished data
9. Dyce these Proceedings

Collections directly into preservatives, such as 70% ethanol, will provide specimens in good condition for taxonomic study. If collections are made into saline, any blood-engorged specimens taken can be tested to determine the source of the blood meal (Walker and Boreham 1976).

However, there are also disadvantages with this method. Light traps do not necessarily attract all spe-

cies equally: indeed, even within a single species there may be differences in attraction depending on physiological state (eg. male or female, gravid or nulliparous). Light traps are not effective in cooler climates or seasons where evening and night temperatures are such that activity by *Culicoides* has ceased by the time it is dark enough for the light in the trap to be attractive.



**Table 2.** Synonyms for *Culicoides* species in China

Previous name	New name	Synonymised by
<i>C. amamiensis</i> Tokunaga	<i>C. sumatrae</i> Macfie	Wirth and Hubert 1989
<i>C. mihensis</i> Arnaud	<i>C. morisitai</i>	Chu Feng-I 1981
<i>C. okumensis</i> Arnaud	<i>C. actoni</i> Smith	Wirth and Hubert 1989
<i>C. sigaensis</i> Tokunaga	<i>C. maculatus</i> Shiraki	Wirth and Hubert 1989

Truck traps also have advantages. As there is no attractant involved, truck traps give an accurate indication of the flight activity patterns of species in relation to time of day, temperature, humidity and wind speed. This method is very useful for detecting daylight and crepuscular activity when cooler temperatures after dark will restrict flight and the usefulness of light traps. However, again there are disadvantages. Truck traps require a vehicle and an experienced operator, and the collection sites must be smooth enough to operate the vehicle comfortably and safely.

**Table 3.** Three common *Culicoides* species from the Oriental region that are confirmed or potential bluetongue vectors, with synonyms and species with which they have been confused (after Standfast et al. 1992).

<i>C. actoni</i>	<i>C. orientalis</i> *
	<i>C. pungens</i> *
	<i>C. imperceptus</i>
	<i>C. okumensis</i>
	<i>C. robertsi</i>
<i>C. brevitarsis</i>	<i>C. orientalis</i> *
	<i>C. radicitus</i>
	<i>C. robertsi</i>
	<i>C. superfulvus</i>
<i>C. oxystoma</i> **	<i>C. schultzei</i> *
	<i>C. alatus</i>
	<i>C. housei</i>
	<i>C. kiefferi</i>
	<i>C. mesopotamiensis</i>
	<i>C. pattoni</i>
	<i>C. punctigerus</i>

\* species with which confusion has occurred in the literature.

\*\* synonyms for *C. oxystoma* are still in a state of flux.

For either of these two methods, it may be necessary to use a screen of mosquito netting, either around light traps or in the mouth of the truck trap. Although biting midges will pass through this screen, it will

keep out the large insects that damage collections and make sorting difficult.

#### Animal bait

This is the most direct method of determining which species feed on livestock, and when they do so. The bait animal must be very quiet and tame enough to allow collecting from head, belly and legs.

#### Larval surveys

Several *Culicoides* species that are confirmed or suspected vectors breed in discrete bovine dung pats (e.g. *C. brevitarsis*, *C. wadai*); in dung and soil mixtures (e.g. *C. imicola*); or at the margins of dung-fouled water (e.g. *C. variipennis*). Sampling of these habitats will almost certainly produce similar connections in China.

Larval surveys allow evidence to accumulate on species that have a close connection with livestock. However, sampling may be labour intensive. If dung is to be held to allow emergence, storage space for containers of dung is required for at least two to three weeks.

### Laboratory Investigations

After key species have been identified by field investigations, two approaches may be used to demonstrate a connection with BLU (or any other viruses). The first is to collect *Culicoides* in the field, sort and identify them and process pools for virus isolation. Collections can either be made 'dry', kept alive and sorted on an entomological chill table; or made into suitable saline fluid in which insects can be sorted and prepared for processing within a short time after collection (Walker and Boreham 1976). In future, the polymerase chain reaction (PCR) test will allow specimens from ethanol to be examined for the presence of viruses.

One useful technique when sorting *Culicoides* for virus isolation attempts is to select only parous specimens. (Testing nulliparous specimens is of no value, as they have not been exposed to virus infection through a blood meal.) Parous *Culicoides* can be detected by the presence of a purple pigment in the walls of the abdomen (Dyce 1969).

However, the collection of insects in the field and their processing for virus isolation is not always an efficient use of scarce resources. In the CSIRO program in the Northern Territory over 18 months during 1974/75, 170 000 *Culicoides* were collected and sorted to species for a single isolation of BLU virus (Standfast et al. 1992). The processing of field collected material gives information on vector status only if BLU virus is isolated. Also, in this type of program other viruses will be isolated too, and if there is no BLU filtering procedure in the laboratory, they will require time and resources for their identification.

The second approach is to use live insects of species suggested as potential BLU vectors and expose them directly to the virus in the laboratory. This can be done either by feeding them on an animal experimentally infected with the virus (Muller 1985) or by artificial feeding through a membrane (Davis et al. 1983). After a suitable incubation period, the insects that feed can be tested to derive an infection rate.

The next stage of the process is to determine the proportion of infected insects that transmit the virus by feeding. As infection rates may be as low as 1%, the most appropriate method of producing known infected insects is to use intrathoracic inoculation with the virus. These insects can be tested for transmission either by allowing them to feed on a host or by capillary tube feeding (Muller 1987). These laboratory procedures are described in more detail by Standfast et al. (1992).

It may still be useful to collect insects in the wild for virus processing, but generally only when the target virus is known to be active in livestock. New technologies, such as PCR, when carefully evaluated for their capacity to detect viruses in insect pools, may make this type of processing more feasible than it has been until now.

In summary, entomologists working on bluetongue vectors in China have an exciting time ahead. If we could make one recommendation, it would be to look carefully at the species that breed in association with dung. In South Africa, Nevill et al. (1992) rated potential orbivirus vectors using several criteria: of the seven species identified as the most likely candidates, six required dung for breeding. In Australia, both *C. brevitarsis* and *C. wadai*, probably the two most important vectors, breed in dung. Given that cattle are an excellent BLU reservoir and amplifier, it would be no surprise if a close relationship has evolved between the virus, the vertebrate and the vectors that are so closely connected to their hosts.

In a country as large as China with such diverse habitats, there will be much to do and much to learn in the study of bluetongue vectors. We look forward with interest to the findings that will be made as this work develops.

## References

- Chu Feng-I. 1977. New species and records of *Culicoides* (Diptera: Ceratopogonidae) from Tibet, China. *Acta Entomologica Sinica*, 20, 99–104.
- 1981. On the blood-sucking midges (Diptera, Ceratopogonidae) from the coastal regions of south-eastern China. *Acta Entomologica Sinica*, 24, 307–313.
- Chu Feng-I and Liu Shu-chung. 1978. A taxonomic study of the genus *Culicoides* (Diptera: Ceratopogonidae) of Yunan, with descriptions of five new species. *Acta Entomologica Sinica*, 21, 79–90.
- Davis, E.L., Butler, J.F., Roberts, R.H., Reinert, J.F. and Kline, D.L. 1983. Laboratory blood feeding of *Culicoides mississippiensis* (Diptera: Ceratopogonidae) through a reinforced silicone membrane. *Journal of Medical Entomology*, 20, 177–182.
- Dyce, A.L. 1969. The recognition of nulliparous and parous *Culicoides* (Diptera: Ceratopogonidae) without dissection. *Journal of the Australian Entomological Society*, 8, 11–15.
- 1979. *Culicoides radicitus* Delfinado: a synonym of *Culicoides brevitarsis* Kieffer (Diptera: Ceratopogonidae). *Journal of the Australian Entomological Society*, 18, 52.
- 1980. Redescription of *Culicoides orientalis* (Diptera: Ceratopogonidae). *Pacific Insects*, 21, 286–292.
- 1982. Distribution of *Culicoides (Avaritia)* spp. (Diptera: Ceratopogonidae) west of the Pacific Ocean. In: St. George, T.D. and Kay, B.H., ed., *Arbovirus research in Australia*, Proceedings 3rd Symposium. CSIRO/Queensland Institute of Medical Research, Brisbane, 35–43.
- 1983. Review of published records of *Culicoides* species in subgenus *Avaritia* (Diptera: Ceratopogonidae) from the New Guinea Subregion. *International Journal of Entomology*, 25, 276–280.
- 1989. Bluetongue vectors in Australia—present and future. In: Uren, M.F., Blok, J. and Manderson, L.H. ed., *Arbovirus research in Australia*. Proceedings 5th Symposium. CSIRO/Queensland Institute of Medical Research, Brisbane, 315–319.
- Dyce, A.L. and Standfast, H.A. 1979. Distribution and dynamics of suspected vectors of bluetongue virus serotype 20 in Australia. In: St. George, T.D. and French, E.L., ed., *Arbovirus research in Australia*. Proceedings 2nd Symposium. CSIRO/Queensland Institute of Medical Research, Brisbane, 28–35.
- Dyce, A.L. and Wirth, W.W. 1983. Reappraisal of some Indian *Culicoides* species in the subgenus *Avaritia* (Diptera: Ceratopogonidae). *International Journal of Entomology*, 25, 221–225.
- Greiner, E.C., Barber, T.L., Pearson, J.E., Kramer, W.L. and Gibbs, E.P.J. 1985. Orbiviruses from *Culicoides* in Florida. In: Barber, T.C., Jochim, M.S. and Osburn, B.I. ed., *Bluetongue and related orbiviruses*. Progress in Clinical and Biological Research, vol. 178. Alan R. Liss Inc., New York, 195–200.
- Jennings, D.M. and Mellor, P.S. 1988. The vector potential of British *Culicoides* species for bluetongue virus. *Veterinary Microbiology*, 17, 1–10.
- Lee, D.J. and Reye, E.J. 1962. Australasian Ceratopogonidae (Diptera, Nematocera). Part X. Additional Australian

- species of *Culicoides*. Proceedings of the Linnean Society of New South Wales, 87, 352–363.
- Lee Tie-sheng. 1979. Biting midges of Tibet, China (Diptera: Ceratopogonidae). Acta Entomologica Sinica, 22, 98–107.
- Meiswinkel, R. 1989. Afrotropical *Culicoides*: a redescription of *C. (Avaritia) imicola* Kieffer, 1913 (Diptera: Ceratopogonidae) with description of the closely allied *C. (A.) bolitinos* sp. nov. reared from the dung of the African buffalo, Blue wildebeest and cattle in South Africa. Onderstepoort Journal of Veterinary Research 56, 23–39.
- Muller, M.J. 1985. Experimental infection of *Culicoides brevitarsis* from South-east Queensland with three serotypes of bluetongue virus. Australian Journal of Biological Sciences, 38, 73–77.
- 1987. Transmission and *in vitro* excretion of bluetongue virus serotype 1 by inoculated *Culicoides brevitarsis*. Journal of Medical Entomology, 24, 206–211.
- Nevill, E.M., Venter, G.J. and Edwardes, M. 1992. Potential *Culicoides* vectors of livestock orbiviruses in South Africa. In: Walton, T.E. and Osburn, B.I., ed., Bluetongue, African horse sickness and related orbiviruses. Proceedings 2nd International Symposium. CRC Press, Boca Raton, 306–313.
- Standfast, H.A., Dyce, A.L. and Muller, M.J. 1985. Vectors of bluetongue virus in Australia. In: Barber, T.L., Jochim, M.M. and Osburn, B.I., ed., Bluetongue and related orbiviruses. Proceedings of the International Symposium. Progress in Clinical and Biological Research, vol.178, Alan R. Liss Inc., New York, 178, 177–186.
- Standfast, H.A., Muller, M.J. and Dyce A.L. 1992. An overview of bluetongue virus vector biology and ecology in the Oriental and Australasian regions of the Western Pacific. In: Walton, T.E. and Osburn, B.I., ed., Bluetongue, African horse sickness and related orbiviruses. Proceedings 2nd International Symposium. CRC Press, Boca Raton, 253–261.
- Steffan, W. 1983. Preparation of slide mounts of Sciaridae (Diptera). International Journal of Entomology 25, 231–232.
- Su Genyuan and Zhou Weihan. 1992. Studies on laboratory rearing of dominant *Culicoides* in Anhui Province. Journal of Anhui Agricultural Sciences, 20, 282–285.
- Tabachnik, W. 1992. Genetics, population genetics, and evolution of *Culicoides variipennis*: implications for bluetongue virus transmission in the USA and its international impact. In: Walton, T.E. and Osburn, B.I., ed., Bluetongue, African horse sickness and related orbiviruses. Proceedings 2nd International Symposium. CRC Press, Boca Raton, 262–270.
- Tanya, V.N., Greiner, E.C. and Gibbs, E.P.J. 1992. Evaluation of *Culicoides insignis* (Diptera: Ceratopogonidae) as a vector of bluetongue virus. Veterinary Microbiology 32, 1–14.
- Walker, A.R. and Boreham, P.F.L. 1976. Saline as a collecting medium for *Culicoides* (Diptera: Ceratopogonidae) in blood feeding and other studies. Mosquito News, 36, 18–20.
- Wirth, W.W. and Dyce, A.L. 1985. The current taxonomic status of the *Culicoides* vectors of bluetongue viruses. In: Barber, T.L., Jochim, M.M. and Osburn, B.I. (ed.), Bluetongue and related orbiviruses. Proceedings of the International Symposium. Progress in Clinical and Biological Research, vol. 178, Alan R. Liss Inc., New York, 151–164.
- Wirth, W.W. and Hubert, A.A. 1989. The *Culicoides* of Southeast Asia (Diptera: Ceratopogonidae). Memoirs of the American Entomological Institute No. 44. 508 p.
- Wirth, W.W. and Marston, N. 1968. A method for mounting small insects on microscope slides in Canada Balsam. Annals of the Entomological Society of America 61, 783–784.
- Wirth, W.W. and Morris, C. 1985. The taxonomic complex, *Culicoides variipennis*. In: Barber, T.L., Jochim, M.M. and Osburn, B.I. ed., Bluetongue and related orbiviruses. Proceedings of the International Symposium. Progress in Clinical and Biological Research, vol.178, Alan R. Liss Inc., New York, 165–175.
- Zhang Nianzu, Zhang Khaili, Li Zhihua, Shanyu Naishun, Hu Yuling, Li Gen, Zhao Kun, Zhou Fuzhong and Xu Wenzhen. 1989. Investigation and study of bluetongue disease of sheep in Yunnan, China. Yunnan Animal Husbandry and Veterinary Journal, 4, 3–12.
- Zhou Weihan, Wan Youren, Cui Shoulong, Liu Shengbao and Su Genyuan. 1991. An investigation on the distribution and seasonal fluctuation of *Culicoides* in Anhui Province, China (Diptera: Ceratopogonidae). Control of Blood-Sucking Dipteran Insects, 3, 156–161.

# Analysis of the Vector and Overwintering Hosts of Bluetongue in Anhui Province, China

Zhou Weihan\*

## Abstract

Twelve species of *Culicoides* are found in China's Anhui Province: *Culicoides actoni*, *C. arakawae*, *C. homotomus*, *C. maculatus*, *C. matsuzawae*, *C. mihensis*, *C. nipponensis*, *C. oxystoma*, *C. pulcaris*, *C. sigaensis* and two species needing further taxonomic comparison. *Culicoides homotomus* may be the vector of bluetongue virus in Anhui Province. First, *C. homotomus* is the dominant species in southern and northern epidemic areas of Anhui. Second, it prefers domestic ruminants. Third, bluetongue disease broke out in the latter part of the peak period of infection, although the peak occurred at a different time in the southern and northern epidemic areas. Both *C. homotomus* and the American *C. variipennis* belong to the subgenus *Monoculicoides*. Comparing the results of agar gel immunodiffusion (AGID) tests, particularly the positive rates of different ruminants in epidemic and non-epidemic areas, and the high positive rate in an area without sheep, it appears that local cattle and buffalo are the main overwintering hosts of bluetongue virus in Anhui Province.

AFTER the isolation and identification of bluetongue virus (BLU) in China's Anhui Province, a general survey of possible vectors and overwintering hosts was carried out in the two bluetongue epidemic areas. This survey aimed to define the dominant species of vector insects and overwintering hosts to formulate appropriate prevention strategies for bluetongue in the Province.

## Materials and Methods

*Culicoides* midges were collected in 33 counties of Anhui Province, giving a survey rate of 37.1%. Net capture was most frequently used, as well as any other appropriate methods. Blood samples from 15 358 ruminants throughout the Province were tested using agar gel immunodiffusion (AGID) performed according to standard procedures.

## Results and Discussion

A total of 22 096 *Culicoides* were captured from 33 counties. Species numbers and distribution (Table 1) suggested that the most probable BLU vectors in Anhui were *Culicoides actoni*, *C. nipponensis* and *C. homotomus*, for the following reasons.

Six species were eliminated from consideration as vectors as they provided just 17 individuals. Although *C. mihensis* was found in the northern epidemic area, its activity peak occurred outside the time of the bluetongue epidemics so that species too was ignored. *Culicoides actoni* has been identified as a BLU vector in Australia, but its numbers in Anhui Province were too low to suggest a similar role without further local confirmation. The very prevalent *C. arakawae* prefers chicken blood, so it too was not considered as a bluetongue vector. There is some debate about the vector role of *C. oxystoma*, the most numerous and widely distributed species of *Culicoides* in the Province. Certainly BLU has already been isolated from this species abroad. However, the vector role for this species in Anhui Province remains unconfirmed because of differences between its activity peak and periods of bluetongue outbreaks. (A.L. Dyce has reported *C. oxystoma* as an 'outlier'.)

---

\* Veterinary Service, Agricultural Department of Anhui Province, No 3 Huizhou Road, Hefei 230001, People's Republic of China.

The most probable vector in Anhui Province was thus *C. homotomus* for the following reasons.

- *Culicoides homotomus* was the dominant species in both number and distribution, and was captured in both epidemic areas.
- It was captured around the bodies of animals and their housing, and the results of electrophoretic analyses of blood meals proved that the blood was from ruminants.
- The activity peak of *C. homotomus* fits the epidemic period of bluetongue. The latent period of both insect and virus suggested a relationship between them.

Research on *C. homotomus* as a BLU vector has been done only in Japan, because the species is confined to Japan and China. However, further study is necessary to confirm its role in China.

Even if a vector were identified, another question, that of the overwintering host, remains. Bluetongue viraemia in an infected animal lasts only 63 days, while the longest activity period of *Culicoides* was 211 days. There must be a host for this gap. A serological survey for bluetongue antibodies using AGID was carried out in Anhui (Table 2). Positive rates among ruminants were ranked, in decreasing order, as Yellow cattle, sheep, buffalo, goats and dairy cows (Table 3). The positive rates among the first three was significantly higher ( $p < 0.01$ ) than those of goats and dairy cows, but there was no significant difference ( $p > 0.059$ ) among the other three. The positive rates among cattle and buffalo were very high in some areas where there were no sheep. Combined with the long period of viraemia (reported to last 42 months)

in cows, it appears that it is cattle and buffalo that are the likely overwintering hosts for bluetongue virus. Additional evidence for this conclusion comes from the significantly higher prevalence of antibodies in cattle, sheep and buffalo in the epidemic areas.

**Table 2.** AGID bluetongue group antibody positive rates among ruminants in Anhui Province, China.

Ruminant	No. positive/No. tested	(%)
Yellow cattle	1231/4554	(27%)
Sheep	1209/4724	(25.6%)
Buffalo	361/1464	(24.7%)
Goat	514/3811	(13.5%)
Dairy cow	37/805	(4.6%)

**Table 3.** Comparison of AGID positive rates in the bluetongue epidemic areas and non-epidemic areas.

Ruminants	No. positive / No. tested		Significance (P)
	Epidemic area	Non-epidemic area	
Yellow cattle	716/1446	515/2108	< 0.01
Sheep	914/2862	295/1862	< 0.01
Buffalo	282/2092	132/1782	< 0.01
Goats	3/12	3358/1452	
Dairy cows	1/1	36/804	
Total	2016/7350	1336/8008	< 0.01

**Table 1.** Distribution of species of *Culicoides* in Anhui Province, China.

<i>Culicoides</i> species	No. of insects captured (%)	No. of counties from which insects collected	Remarks
<i>C. oxystoma</i>	10719 (48.5)	32	
<i>C. homotomus</i>	6587 (29.8)	31	in both epidemic areas
<i>C. nipponensis</i>	3153 (14.3)	26	in both epidemic areas
<i>C. arakawae</i>	1423 (6.4)	25	chicken feeder
<i>C. mihensis</i>	120 (0.5)	7	not in southern epidemic area
<i>C. actoni</i>	77 (0.3)	10	in both epidemic areas
<i>C. maculatus</i>	17 (0.1)	-	these six species seldom seen
<i>C. matsuzawae</i>			
<i>C. pulcaris</i>			
<i>C. sigaensis</i>			
undefined			
undefined			
Total	22096	32	

# A Comparison of the Geographic Distribution and Dynamics of *Culicoides* in Anhui Province, China

Zhou Weihai\*, Su Genyuan†, Cui Shoulong§ and Xue Chaoyang¶

## Abstract

An investigation was carried out to help search for arbovirus vectors in Anhui Province. By geographical classification, Anhui province is an intermediate area between the Oriental and Palaearctic regions. The Changjiang and Huaibe rivers run from west to east and divide the province into three natural zones: the Jianghui zone (between the Huaibe and Changjiang rivers), the Huaibe zone (north of the Huaibe River) and the Jiangnan zone (south of the Jaingsun river). *Culicoides oxystoma* and *C. homotomus* are the dominant *Culicoides* species in the whole province. Another dominant species, *C. nippenensis*, was more abundant in the Jainghuai Zone than in the Huaibe and Jiangnan zones. In all three zones, *C. actoni* comprised less than 1% of the *Culicoides* population. One species, *C. mihensis*, was collected only in the Huaibe Zone, not in the other two. The first successful collection date for *Culicoides* at the southern point (32°15'N, 18°18'E) occurs earlier than at the northern point (34°4'N, 117°2'E), and the final collection date of the season occurs later. The appearance, duration and termination of all species was respectively earlier, longer and later at the southern point, perhaps because of the 2° difference in latitude.

---

\* Veterinary Service of Anhui Province, People's Republic of China.

† Anhui Institute of Husbandry and Veterinary Science, People's Republic of China.

§ Animal Husbandry and Veterinary Medicine Station of Chuzhou City, Anhui Province, People's Republic of China.

¶ Animal Husbandry Technical Centre of Xiaoxian, Anhui Province, People's Republic of China.

# A Study on Laboratory Rearing of Dominant *Culicoides* in Anhui Province, China

Su Genyuan\* and Zhou Weihai<sup>†</sup>

## Abstract

An investigation was carried out into the blood-feeding habits and breeding sites of four species of *Culicoides* (*C. schultzei*, *C. homotomus*, *C. nipponensis* and *C. arakawae*), which are suspected vectors of infectious diseases in Anhui Province. Techniques for rearing *Culicoides* in the laboratory were evolved, with a success rate of 4.7% with *C. nipponensis* adults.

---

\* Anhui Institute of Husbandry and Veterinary Science, AAAS, Hefei 230031, People's Republic of China.

<sup>†</sup> Veterinary Service of Anhui Province, Hefei 230021, People's Republic of China.

# A Comparison of Methods for Isolating Arboviruses from Insects

Li Xiaocheng, Cheng Zhongguo, Zhan Yanxia and Meng Guangxiao\*

## *Abstract*

Arbovirus isolations were made from 97 field samples from certain *Culicoides* species. Various methods were used, including inoculation and propagation in yolk sacs of embryonated eggs, in suckling mice, and on cells either of a single kind or of two kinds in various ways. The rates of success for virus isolation were 8.9% in embryonated eggs; 21.6% in mouse brains; 28.9% in cells of a single kind; and, most effective, 62.5% in cells in alternate ways.

---

\* Animal Quarantine Institute, Ministry of Agriculture, Qingdao 266032, People's Republic of China.



# Application of the Polymerase Chain Reaction (PCR) Test with Insects in Studying Bluetongue Virus Activity

L.F. Melville\*, N.T. Hunt\* and P.W. Daniels†

## Abstract

The polymerase chain reaction (PCR) test for bluetongue viruses offers a sensitive and specific means of detecting the presence of bluetongue nucleic acid in samples. Two different tests have been developed so far. In the first, a genome fragment from the bluetongue viral RNA3 segment is amplified: RNA3 codes for the capsid protein VP3, and is substantially conserved among bluetongue serotypes. Within the limits of test sensitivity, a single test can determine the presence or absence of a bluetongue virus. In the second type of test, PCRs for each of the BLU serotypes have been developed, based on serotype-specific domains in RNA2 segment coding for VP2, the outer coat protein of the virus. Either test can be applied to insect specimens, but first the test must be standardised so that its sensitivity in detecting one infected insect in insect pools of various sizes is known. In monitoring programs, PCR offers the opportunity to detect bluetongue virus in insects collected from remote locations where sentinel cattle cannot be used for routine sampling. In research, studies of insect vector-virus-mammalian host cycles of infection can be attempted, because PCR gives an efficient way of detecting the viruses in the insect phases of their life cycles. Both PCR applications are currently being developed in the Northern Territory of Australia.

ARBOVIRUSES, by definition, are spread among mammalian hosts by insect vectors, with the virus undergoing an obligatory cycle of replication in the insect as well as in the mammalian host. Epidemiological studies of arboviruses must include the insect phase of the infection cycle before a full understanding is possible. However, including insect studies adds substantially to the required resources: a qualified entomologist with specialist knowledge of *Culicoides* species must be available at the right time and place, as must the equipment for handling insects. If live or cold-preserved insects are needed, for virus isolation or vector studies, such equipment needs can be limiting.

Polymerase chain reaction (PCR) amplification of specific sequences of nucleic acid (Saiki et al. 1988)

can be applied to alcohol-fixed specimens, and thus offers new opportunities and flexibility to studies of associations of infectious agents with insects. Insects can be collected by light trap into 70% alcohol at near or remote locations with minimum facilities, be stored cheaply and without the need for specialised equipment, and transported to an entomologist for sorting and identification at a mutually convenient time (Daniels and Sendow these Proceedings).

A prerequisite for studies with any particular virus is a PCR test of known and appropriate specificity. Considerable developmental work has been reported on such PCR tests for bluetongue viruses (BLU) in the Australian region (Gould et al. 1989; Gould and Pritchard 1991; McColl and Gould 1991, 1994; McColl et al. 1994; Pritchard et al. 1995). In summary, a PCR test that detects nucleic acid from all known bluetongue viruses has been developed, based on amplification of nucleic acid from the virus RNA segment 3 which codes for the well conserved inner capsid protein VP3. Sensitivity of this primary PCR has been increased by the addition of a sequential round of amplification using 'nested' primers: these

\* Department of Primary Industry and Fisheries, Berrimah Agricultural Research Centre, PO Box 79, Berrimah, Darwin, Northern Territory 0828, Australia.

† CSIRO Australian Animal Health Laboratory, PO Bag 24, Geelong, Victoria 3220, Australia.

initiate a PCR for a smaller fragment of the gene contained within the segment amplified in the first reaction, giving a nested PCR. In addition, primary PCRs have been developed for specific Australian BLU serotypes, based on the serotype-specific VP2.

Importantly, nucleotide sequences in BLU RNA segments have been shown to vary between isolates, even of the same serotype. Relationships can be detected among isolates: those with closer sequence homology tend to be derived from one geographic area. These relationships are independent of serotype. After information on a sufficient number of isolates of known origin and date of isolation has been analysed it is possible to nominate the probable geographic origin of new isolates based on their sequence relationships to those already known. These relatively new observations have led to the concept of 'topotyping' (Trent et al. 1981; Gould et al. 1989; Pritchard et al. 1995).

The present studies in the Northern Territory, promoted by the Exotic Animal Disease Preparedness Consultative Council (EXANDIS), are part of a collaborative project in technology transfer between the Berrimah Agricultural Research Centre and the CSIRO Australian Animal Health Laboratory, Geelong, Victoria. Our purpose is to devise strategies for the application of newly available molecular techniques to epidemiological studies of bluetongue viruses in Northern Australia, as well as more efficient monitoring strategies. In this paper we describe approaches being developed to apply PCR technology to the detection of bluetongue viruses in insects.

### **Potential Applications for PCR Investigations of Insects**

In large countries such as Indonesia and Australia, much is already known of the BLU fauna from isolations of viruses from sentinel animals (Sukarsih et al. 1993, Melville et al. these Proceedings; Sendow et al. these Proceedings). Light trap collections of insects may offer a preferable monitoring strategy for specific purposes under some circumstances for example, to confirm the presence of virus in an area where monitoring of sentinel animals is not practical for logistical or social reasons. In this case, insects need not necessarily be identified to species, nor should having a blood meal lead to exclusion, since the aim is not to make inferences about vectors but simply to confirm the presence of virus at the sampling location. Efficiency of virus detection would increase with the sorting of insects into pools of potential vectors.

Sequence analysis of the PCR product, or topotyping, could give additional information as to whether the detected virus was potentially a recent introduc-

tion to the sampling area, as long as the expected toptype was known from previous experience (McCull et al. 1994). Detection of a toptype of concern would lead to further monitoring to attempt to describe its distribution.

If insect collections are reliably sorted to species, and according to normal protocols for virus isolation before PCR analysis, one can establish specific associations of viruses with wild caught insect species, one of the steps in determining vector status.

These PCR applications should also be useful in epidemiological studies of the dynamics of natural viral infection cycles in vector-mammalian host ecosystems. Such studies are not presently attempted because they require excessive amounts of limited resources. At the Coastal Plains Research Station in the Northern Territory, each week insects are collected and viruses isolated from sentinel cattle, with great efficiency (Gard and Melville 1992; Melville et al. these Proceedings). In this setting, it is proposed to plot the temporal relationship between infections in the vector species present and the flux of viraemia in the sentinel cattle group. Strategies will also be investigated to determine the infection rates in various vector species as the wave of virus infection moves through the sentinel herd. Such data will provide an understanding of events that may allow predictions of the probabilities of spread of any BLU serotype, given the prevailing population characteristics of the vectors present at the time.

### **Limitations to the Application of PCR in Insects**

#### **Sensitivity of PCR in insect homogenates**

As with any PCR test, proper application depends on a knowledge of its sensitivity in detecting virus. With insect material, PCR may be less sensitive than with other specimens. Three major concerns must be identified. First, with large pool sizes dilution factors may become important. Second, insect homogenates may contain inhibitors of the various PCR processes (Sellner et al. 1993): the probability of high levels of RNAses interfering with RNA extraction has been noted (Noriega and Wells 1993). Third, sensitive procedures must be developed and their sensitivity known before serious application is attempted, otherwise negative results will be difficult to interpret. Knowledge of the probability of detecting one infected insect in pools of various sizes is of particular importance.

#### **The biology of the virus in the insect**

As with the isolation of viruses from insects, the detection of virus by PCR does not confirm vector

status. To do the latter, vector competency studies must confirm that the species is able to transmit the virus biologically. Sources of viral RNA that are theoretically detectable by PCR include possible survival or retention of virus after a blood meal in the insect gut, or possible multiplication of the virus without concomitant ability to transmit. Muller (pers. comm.) has recommended studies of the kinetics of PCR-detectable material in experimentally infected insects after a blood meal to develop an appreciation of likely PCR observations during different phases of the insect's life cycle.

Another possible biological constraint to applying PCR in studies of virus infections in *Culicoides* populations is the low infection rate observed with some species. For example, although *C. fulvus* had infection rates of 43% for BLU1 and 64% for BLU20, *C. brevitarsis* had infection rates of just 0.2% to 0.3% for BLU1, 20 and 21 (Standfast et al. 1985). Detecting virus-infected insects under such circumstances would necessitate the processing of either pools of extremely large sizes (which that may be confounded by factors mentioned above) or a large number of smaller pools, reducing the cost-effectiveness of the technique. However, PCR studies on natural populations may give an indication of infection rates in nature.

## Materials and Methods

To assess PCR sensitivity in the detection of infected insects, we inoculated insects with virus and added them to uninoculated insects in varying pool sizes. Insects were caught in an updraught light trap at Coastal Plains Research Station (12° 39'S, 131°E, ). *Culicoides peregrinus* was chosen as the test species because of its large size (making inoculation easier), its abundance and its reported ability to support BLU replication (Standfast et al. 1985). Individual *C. peregrinus* were sorted from the collection and held in an incubator for 24 hours at 26° C and 85% relative humidity, with access to 10% sucrose solution as a food source. After 24 hours, surviving insects were inoculated (Muller 1987) with BLU1 (CSIRO 156 strain) at a titre of 6.75 log<sub>10</sub> TCID<sub>50</sub>. After inoculation, insects were returned to the incubator and held for varying times post-inoculation depending on survival. The longest surviving insect was held for 20 days post-inoculation.

Pools were made of inoculated and uninoculated insects, at ratios varying from 1:5 to 5:50. These insect pools were held either at -20°C or at 4°C until processed. Insect pools were ground in 50 mL of sterile distilled water using a disposable mortar and pestle for each sample. The sample was made up to 50

mL, digested RNA extracted, cDNA prepared, primary and nested PCRs performed and products analysed (McColl et al. 1994). Primers used were based on RNA3 of BLU1 (Pritchard et al. 1994).

A similar PCR technique was applied to wild-caught alcohol-fixed insects. Insects were caught in a downdraught light trap into alcohol. Traps were set weekly at Coastal Plains Research Station and samples were examined from October to April. The PCR results were compared with virus isolations from cattle over the same period.

## Results and Discussion

Although there was a slight tendency for PCR reactions to occur in the smaller pools of experimentally infected insects, no clear trend has emerged (Table 1). Further studies are necessary, replicated to control for possible failure of viruses to propagate in inoculated insects.

**Table 1.** PCR detection of bluetongue-inoculated *Culicoides* in pools of uninoculated *Culicoides*.

Ratio of infected : uninfected	No. of pools tested	No. of pools positive by PCR
1 : 5	4	4
2 : 5	3	1
1 : 10	2	1
2 : 10	3	1
5 : 10	1	1
1 : 20	2	1
2 : 20	2	1
1 : 50	1	0
2 : 50	1	0
5 : 50	2	2

In the pilot investigation of field-caught insects (Table 2), BLU was detected in all four species of known vectors (*C. actoni*, *C. brevitarsis*, *C. fulvus* and *C. wadai*), as well as in separate pools of *C. peregrinus* and *C. oxytoma* (data not presented). The findings represent the first PCR detection of BLU in field-caught insect specimens for all these species except *C. wadai*, which has yielded PCR product previously (McColl et al. 1994). The result for *C. actoni* was the first demonstration of BLU in wild-caught insects for that species, with the other species having been implicated previously through various isolation techniques (Standfast et al. 1985) or, in the case of *C. wadai*, by PCR.

Quite small pools of *C. wadai* and *C. fulvus* were PCR positive, indicating quite high infection rates at that time. BLU was detected by PCR in pools of 25

and 50 *C. brevitarsis*, even though only a few pools were processed. This suggests the technique could be applied to that species even with its predicted lower infection rates.

**Table 2.** Summary of *Culicoides* species showing positive for bluetongue virus by PCR.\*

<i>Culicoides</i> species	Month	No. of insects	No. of pools	No. of pools positive by PCR
<i>C. brevitarsis</i>	October	160	5	0
	November	160	5	0
	December	370	11	3
	January	100	2	0
	February	50	1	1
<i>C. wadai</i>	October	5	1	0
	November	2	1	1
	December	40	4	2
	January	91	4	2
	February	25	1	0
<i>C. fulvus</i>	October	1	1	0
	November	1	1	0
	December	3	2	1
	January	102	4	4
	February	50	1	0
<i>C. actoni</i>	December	12	1	1
	January	54	2	1
	February	4	1	0

\*Preliminary data

The results can be further assessed to show how studies of the dynamics of virus infections in a natural vector-mammalian host ecosystem might be conducted. Observations were made during the time that BLU21 was known to be circulating among a group of sentinel steers at Coastal Plains Research Station. The first isolation, from a single infected animal, was on 20 October 1994, and the last isolation, when again only one animal of the group was infected, was on 9 March 1995. Periods of viraemia in infected steers lasted from one to four weeks, as assessed by virus isolation. All 20 steers were infected during this infection cycle (Fig. 1).

A means of identifying the peak of the infection cycle in the steers was needed, to indicate the pool of animals infected each month resulting from insect infections, and in turn contributing to the number of insects infected. The number of viraemic animals each week was determined, and monthly totals calcu-

lated, giving values for 'viraemia-weeks' per month. This measure (Fig. 1), analogous to 'person-days' per month (eg. working on a project), was plotted to give a clear representation of the peak of the infection

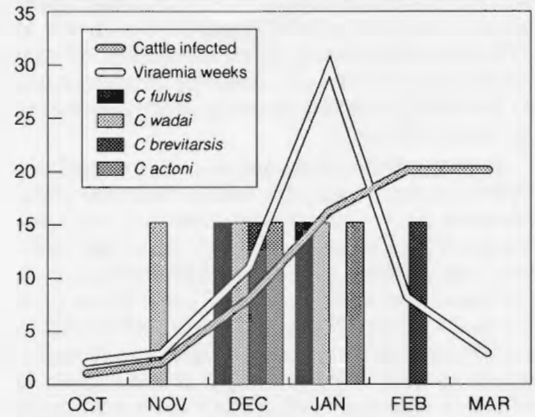

**Figure 1.** Dynamics of BLU 21 infection in cattle and insects.

cycle, compared with the cumulative total of the number of animals infected.

Also plotted were the monthly data on the vector species identified as infected by PCR (Fig. 1). When the infection cycle began, only *C. wadai* was identified as PCR positive. As the cycle gained momentum, all four vector species were implicated. As long as adequate numbers of insects of each species are tested each month, such data may show which vector species is involved in introducing the infections to the sentinel group. Similarly, subject to certain assumptions, the vectors involved in propagating the wave of each infection may be determined. On this occasion there was a maximum (100%) incidence of infection of the mammalian host sentinels, but this is not always, or even usually, the case (Daniels and Sendow, these Proceedings). The comparative involvement of vectors during less efficient cycles of infection could be observed in future studies. Also, as certain BLU serotypes and two of the four vectors are restricted to the north of the Northern Territory, it will be important to establish whether all four vectors are equally involved in the propagation of all eight Australian serotypes, or whether apparent vector-serotype preferences can be distinguished (Daniels and Sendow, these Proceedings).

These preliminary studies have provided novel observations of aspects of BLU epidemiology in the Northern Territory. There seems adequate justification for developing these approaches further, by defining the sensitivity of PCR more precisely and by

developing epidemiologically-sound sampling protocols on the basis of that information.

## Acknowledgments

Insects were identified to species by Glen Bellis (North Australian Quarantine Strategy) and Bill Doherty (Queensland Department of Primary Industry). Glen Bellis and Mike Muller advised on insect inoculation.

## References

- Gard, G.P. and Melville, L.F. 1992. Results of a decade's monitoring for orbiviruses in sentinel cattle pastured in an area of regular arbovirus activity in northern Australia. In: Walton, T.E. and Osburn, B.I., ed., *Bluetongue, African horse sickness and related orbiviruses*. Proceedings 2nd International Symposium. CRC Press, Boca Raton, 85-89.
- Gould, A.R. and Pritchard, L.I. 1991. Phylogenetic analyses of the complete nucleotide sequence of the capsid protein (VP3) of Australian epizootic haemorrhagic disease of deer virus (serotype 2) and cognate genes from other orbiviruses. *Virus Research*, 21, 1-18.
- Gould, A.R., Hyatt, A.D., Eaton, B.T., White, J.R., Hooper, P.T., Blacksell, S.D. and Le Blanc Smith, P.M. 1989. Current techniques in rapid bluetongue virus diagnosis. *Australian Veterinary Journal*, 66, 450-454.
- McColl, K.A. and Gould, A.R. 1991. Detection and characterisation of bluetongue virus using the polymerase chain reaction. *Virus Research*, 21, 19-34.
- 1994. Bluetongue virus infection in sheep: haematological changes and detection by polymerase chain reaction. *Australian Veterinary Journal*, 71, 97-101.
- McColl, K.A., Gould, A.R., Pritchard, L.I., Melville, L. and Bellis, G. 1994. Phylogenetic characterisation of bluetongue viruses from naturally-infected insects, cattle and sheep in Australia. *Australian Veterinary Journal*, 71, 102-105.
- Muller, M.J. 1987. Transmission and *in vitro* excretion of bluetongue virus serotype 1 by inoculated *Culicoides brevitaris* (Diptera: Ceratopogonidae). *Journal of Medical Entomology*, 24, 206-211.
- Noriega, F.G. and Wells, M.A. 1993. A comparison of three methods for isolating RNA from mosquitoes. *Insect Molecular Biology*, 2, 21-24.
- Pritchard, L.I., Gould, A.R., Wilson, W.C., Thompson, L., Mertens, P.P.C. and Wade-Evans, A.M. 1995. Complete nucleotide sequence of RNA segment 3 of bluetongue serotype 2 (Ona-A). Phylogenetic analyses reveal the probable origin and relationship with other orbiviruses. *Virus Research*, 35, 247-261.
- Saiki, R.K., Gelfand, D.H., Stoffel, S., Scharf, S.J., Higuchi, R., Horn, G.T., Mullis, K.B. and Erlich, H.A. 1988. Primer-directed enzymatic amplification of DNA with a thermostable DNA polymerase. *Science*, 239, 487-491.
- Sellner, L.N., Coelen, R.J. and Mackenzie, J.S. 1993. Detection of Ross River virus by PCR. In: Uren, M.F. and Kay, B.H. ed., *Arbovirus research in Australia*. Proceedings 6th Symposium. CSIRO/Queensland Institute of Medical Research, Brisbane, 81-83.
- Standfast, H.A., Dyce, A.L. and Muller, M.J. 1985. Vectors of bluetongue in Australia. In: Barber, T.C., Jochim, M.S. and Osburn, B.I. ed., *Bluetongue and related orbiviruses*. Progress in Clinical and Biological Research, vol. 178. Alan R. Liss Inc., New York, 177-186.
- Sukarsih, Daniels, P.W., Sendow, I. and Soleha, E. 1993. Longitudinal studies of *Culicoides* spp. associated with livestock in Indonesia. In: Uren, M.F. and Kay, B.H. ed. *Arbovirus research in Australia*. Proceedings 6th Symposium. CSIRO/Queensland Institute of Medical Research, Brisbane, 203-209.
- Trent, D.W., Grant, J.A., Vorndam, A.V. and Monath, T.P. 1981. Genetic heterogeneity among Saint Louis Encephalitis Virus isolates of different geographic origin. *Virology*, 114, 319-332.

# Entomology Workshop

Convened by H.A. Standfast and M.J. Muller

## Collection Techniques

Participants discussed the use, and application to various species of insect, of light traps, truck traps, manitoba traps and mechanical aspirators, with respect to the collection of *Culicoides* for manipulation in the laboratory. One important aspect was the requirement to minimise stress on the insects during the collection process so they would survive the 10 to 15 days required for laboratory experiments.

## Infecting *Culicoides* in the Laboratory

Techniques for infecting insects were discussed, including methods for feeding insects on viraemic animals (and restraining the latter); techniques for feeding *Culicoides* blood virus mixtures through a membrane; and techniques for inoculating *Culicoides* with virus suspensions.

## Laboratory Transmission

Systems similar to those used for feeding *Culicoides* on viraemic sheep were outlined. M.J. Muller described a technique he had developed for collecting saliva from infected *Culicoides* and for recovering virus from the saliva. Bluetongue viruses can be identified by direct cultivation or polymerase chain reaction (PCR).

## Vector Efficiency

Techniques for measuring vector competence were outlined. The traditional method, of feeding insects on infected sheep and transmitting the virus to sus-

ceptible sheep, requires insect-proof animal accommodation. A second method, which can be used in a normal laboratory, involves feeding insects on blood virus mixtures through a membrane, then inducing the infected insects to feed on serum saline in a capillary. The saliva-contaminated serum saline is then assayed for the presence of virus either by inoculating tissue culture or by the use of PCR.

## Control of *Culicoides*

For too long control agencies have concentrated on the use of vaccines, ignoring the possibility of controlling the vector. In the last two decades several techniques developed to control mosquitoes have shown promise for the control of *Culicoides*. Some systemic insecticides are useful, while some vector species can be controlled simply by changing hygiene and farming practices. For nearly a quarter of a century the philosophy of integrated control has been applied to disease management. It is time it was applied to bluetongue.

## Conclusion

Symposium delegates attending the Entomology Workshop participated actively in the discussions and hoped that, at the next Symposium, some results of studies on vector competence will be available for discussion. One outcome of the Workshop was the identified need for a Chinese entomologist to receive specialist training on the taxonomy and biology of *Culicoides* to advance the task of identifying which species of *Culicoides* in China are bluetongue vectors. Table 1 provides a list of *Culicoides* species fully identified from cleared and mounted species.

**Table 1.** Identification of *Culicoides* species collected in China between 1987 and 1991. (Collected by S.S. Davis, Li Haichun, M.J. Muller and T.D. St. George; identified by A.L. Dyce.).

Species	Songhua <sup>a</sup> 16 Jun 1987	Longjiang <sup>b</sup> 25 May 1989	Lufengchun <sup>c</sup> 20 Oct 1991	Yiliang <sup>d</sup> 21 Oct 1991
<i>C. (Avaritia) imicola</i> Kieffer	+		+	
<i>C. (Avaritia) jacobsoni</i> Macfie	-		+	+
<i>C. (Avaritia) maculatus</i> (Shiraki)	+		+	+
<i>C. (Avaritia) sp (?) obsoletus</i> Meigen	-		+	
<i>C. (Avaritia) orientalis</i> Macfie	-		+	
<i>C. (Avaritia) sp. nr pastus</i> Kitaoka	-		+	+
<i>C. (Avaritia) sinanoensis</i> Tokunaga	+			
<i>C. (Avaritia) suzukii</i> Kitaoka				+
<i>C. (Culicoides) pulicaris</i> group	+		+	+
<i>C. (Monoculicoides) homotomus</i> Kieffer	+			
<i>C. (Hoffmania) nipponensis</i> Tokunaga	-	+		
<i>C. (Hoffmania) sumatrae</i> Macfie	-		+	
<i>C. (Meijerehelea) arakawae</i> (Arakawa)	-	+	+	
<i>C. (Trithecoides) sp. (? humeralis/palpifer)</i>	-	+	+	
<i>C. (Remmia) oxystoma</i> Kieffer	+	+	+	
<i>Forcipomyia</i> sp.				+

<sup>a</sup> Songhua Dairy, north of Harbin, Heilongjiang Province 45°50'N, 126°5'E.

<sup>b</sup> Lufengchun, Yunnan Province 25°10'N, 102°E.

<sup>c</sup> Yiliang, Yunnan Province 25°N, 103°20' E.

<sup>d</sup> Longjiang Experimental Station, southwest Foshan, Guangdong Province 22°50'N, 113°10'E.

+ Species present in collections made at locations <sup>a</sup>, <sup>b</sup>, <sup>c</sup> and <sup>d</sup>.

# Bluetongue Vector Surveillance in Yunnan and Sichuan Provinces of China

Li Huachun\*, Li Zhihua\*, Zhang Khaili\*, Liu Gui\*, Zhou Fuzhong\* and Shun Yourong<sup>†</sup>

## *Abstract*

Bluetongue is a virus of ruminants transmitted by *Culicoides* species. In 1994, the surveillance and studies of bluetongue vectors began in Shizong and Kunming in Yunnan Province, and in Wuxi County in Sichuan Province. Twenty-three species of *Culicoides* have been collected, of which at least six are bluetongue-related vectors. Five species (*Culicoides actoni*, *C. brevitarsis*, *C. imicola*, *C. maculatus* and *C. orientalis*) are found in Yunnan, while another species, *C. fulvus*, is found in Sichuan.

---

\* Yunnan Tropical and Subtropical Animal Virus Diseases Laboratory, Jindian 650224, Kunming, People's Republic of China.

<sup>†</sup> Animal Quarantine Station of Wanxian City, Wanxian 634000, People's Republic of China.



# **Virology, Serology and Pathogenesis**

# Introduction

BLUETONGUE has many vertebrate hosts, including ruminants of several species, both domesticated and wild. Our understanding of the effect of bluetongue on these hosts has been clouded by the unwarranted extrapolation from data from a single source some years ago. Now there is solid evidence that bluetongue is an infection or disease of finite duration.

Bluetongue is a disease produced by a group of closely related viruses which circulate in ruminants in a vast area of the world. Humans have domesticated only a few of the species infected by these viruses. Among these domesticated species, only certain breeds of sheep experience the more severe effects on their vascular endothelium which produce the clinical effects that we call bluetongue disease. We have not yet identified the differences between hosts which mean that, when infected with the same virus, some respond with disease and some do not.

In these Proceedings, very strong evidence is advanced to suggest that bluetongue viruses persist for less than 150 days, and that this is directly determined by the life span of red cells to which virus adsorbs during a short replication period. The presence of neutralising antibodies in the plasma of

infected ruminants, and the declining titre of virus, makes the real infective period when suitable *Culicoides* vector species feed on the infected animal very much shorter.

The recognition that bluetongue virus is stable in blood samples held above freezing temperature, and the improvement of cultural techniques, are leading, in China and Southeast Asia, to the accumulation of many strains of a wide range of serotypes from hosts of known history. This new wealth of material is allowing the evaluation of more recently developed serological methods, in particular the competitive enzyme linked immunosorbent assay (cELISA).

Similarly, the role for polymerase chain reaction (PCR) is beginning to come into focus. Its use can speed up screening techniques remarkably, whether applied to the blood of insects or ruminants. However, PCR does not replace methods which yield viable viruses for typing or testing for pathogenicity. Approaches using combinations of PCR, virus isolation and cELISA need encouragement throughout the Asian-Pacific region in this exciting period of the exploration of bluetongue.

# **The Pathogenesis of Bluetongue Virus Infection of Cattle: a Novel Mechanism of Prolonged Infection in which the Erythrocyte Functions as a Trojan Horse**

**N.J. MacLachlan\***

## *Abstract*

Bluetongue is an arbovirus disease of ruminants. Cattle are a reservoir host of bluetongue virus (BLU). Virus amplification occurs in infected cattle: these animals then have a prolonged infection during which they provide a source of virus for the haematophagous midge (*Culicoides*) vector. Primary replication of BLU within infected cattle occurs in the lymph node draining the site of virus inoculation. Virus is then disseminated to secondary sites such as the spleen. Initially, virus released into the circulation promiscuously associates with all blood cells, in titres proportionate to the relative concentration of each cell type in blood, but late in the course of infection virus is exclusively associated with erythrocytes. Viraemia persists for up to eight weeks as determined by virus isolation, whereas it may be detected by polymerase chain reaction (PCR) analysis for up to 140 to 160 days after infection, but not thereafter. Association of BLU with blood cells, especially erythrocytes, facilitates prolonged viraemia in infected cattle but does not affect other potential mechanisms such as antigenic drift of BLU or deficits in the host's antiviral response. BLU replicates in bovine monocytes and CD4+ T cells *in vitro* but not in other blood cell types. Significantly, BLU rapidly binds bovine erythrocytes through a highly specific interaction. Virus particles then persist for prolonged periods in membrane bound invaginations. This novel interaction of BLU and bovine erythrocytes may allow cattle to function as a reservoir host for bluetongue virus, by facilitating both the prolonged viraemia in infected cattle and infection of the haematophagous insect vector.

---

\* School of Veterinary Medicine, University of California, Davis, California 95616, USA.

# Research on the Basic Properties of Chinese Bluetongue Viruses

Li Zhihua, Zhang Khaili, Li Gen, Hu Yuling, Peng Kegao and Wu Dexing\*

## Abstract

Research on different local strains of bluetongue viruses (BLU) from Yunnan, Hubei, Sichuan, Inner Mongolia and Xinjiang Provinces has shown the following characteristics. Under the electron microscope, the virions present a spherical shape with no envelope and a diameter of 65–70 nm. According to polyacrylamide gel electrophoresis (PAGE), the BLU genome comprises 10 RNA segments with an electrophoretic profile of 3.3.3.1., but there are differences among strains. The physical and chemical properties of the Y33F5 strain from Yunnan, passaged through sheep, were investigated. This strain was not inactivated under conditions of 1.5% methanol, 3% Na<sub>2</sub>CO<sub>3</sub>, 3% lysol and chloroform, or being held at 56°C for 30 minutes. However, it was inactivated completely under conditions of 3% carbolic acid, 75% ethanol, 39% NaOH, 0.2% peracetic acid and 2% ether, or being held at 80°C for 15 minutes. Both Y33 and Y55 strains of BLU1 from Yunnan retained their virulence stability for at least 28 months after treatment with citric acid anticoagulant and storage at 4°C. After 22 passages, the viruses remain pathogenic to sheep with an ID<sub>50</sub>/5 mL of 2.5 and 2.75 (log<sub>10</sub>) respectively.

BLUETONGUE viruses (BLU) are classified as orbiviruses in the family Reoviridae. The virus particles measure 65–70 nm in diameter and are icosahedral in shape. Mature virus has no envelope and contains seven structural proteins. The viral nucleus comprises 10 double stranded RNA segments. Methods of BLU isolation, culture, physical and chemical properties, purification and experimental infection of animals have been studied systematically all over the world. In China, basic studies started in 1979 after the first isolation of a bluetongue virus.

The first step in genomic research is purification of the virus. This depends on the physical, chemical and biological properties of the virus. Bluetongue viruses are resistant to ether, chloroform and F113, and sensitive to low pH but stable at high pH. Standard purification procedures involve abstracting the material, partly de-proteinising and de-lipidising with a

lipophilic solution, and centrifuging in discontinuous gradient sucrose or in caesium chloride many times to obtain a highly purified protein (Fernandes 1959; Els and Verwoerd 1969; Verwoerd 1969; Bowne 1971). Problems with the procedure include overelaborated operation needing time-consuming and expensive equipment; unsatisfactory results from unstable viruses (Els and Verwoerd 1969); and toxicity of caesium chloride causing losses of BLU activity (Els and Verwoerd 1969). As we wanted to establish a method without these disadvantages, we used the molecular sieve and found this satisfactory.

Blood cells were the best materials for both animal inoculation and virus purification. During the initial stages of infection, BLU is attached to the surface of red cells (Alstad et al. 1977). Most attachment occurs on the ninth day post infection, just before appearance of neutralising antibodies (Klontz et al. 1962). While infection can be achieved by intradermal inoculation (Fernandes 1959), a subcutaneous inoculation of 1 mL high titre infectious virus is the main method used in animal experiments (Bowne 1971). Resistance of BLU to storage temperatures is high: activity

\* Yunnan Tropical and Subtropical Animal Virus Diseases Laboratory, Jindian 650224, Kunming, People's Republic of China.

in uncoagulated blood can last 25 years at room temperature (Neitz 1948). Many other reports confirm these findings (Bowne 1971; Guo Zaijun et al. 1989; Lin Lihui et al. 1989; Li Zhihua et al. 1989; Zhang Nianzu et al. 1989a). Experiments on inoculating sheep and detecting BLU in different organs, as well as resistance to general disinfectants and temperature have been conducted by Bowne (1971), Zhang Nianzu (1989a) and Qin Qiying et al. (1991).

Our experiment aimed to measure the passaging of a Yunnan virulent BLU strain, its preservation and the 50% infection dose (ID<sub>50</sub>) of sheep.

## Materials and Methods

BHK21 cells were cultured and passaged by generally used methods, with the following BLU isolates:

- Y863 isolated from a sheep in Shizong farm, Yunnan
- WFX from Zhaochong farm, Hubei (Zhang Nianzu et al. 1989b)
- NMFx from Bayannur region, Inner Mongolia (Li Zhihua et al. 1989)
- SWFx from a newly opened-up region in Sichuan (Lin Lihui et al. 1989)
- SFx from a goat in Xinjiang (Guo Zaijun et al. 1989)
- BLU10 and BLU17 as positive controls imported from USA.

All the viruses caused obvious cytopathic effect (CPE) in BHK21 cell sheets. We used the method of virus amplification, harvest and concentration described by Qin Qiying et al. (1991), abstracting by adding an equal volume of F113 to concentrated virus and storing in a 4°C waterbath.

We used a Sephadax-G200 (Pharmacia, F113) molecular sieve (supplied by Shanghai Chemical Reagent Supply Company) and TES elutant. Collectors were partly used for collection with a 280 nm detecting solution for detecting nucleic acid and graphs were recorded automatically. The ID of each peak was evaluated and examined by electron microscopy and PAGE, and the virus activity tested by inoculation into BHK21 cells.

The five domestic isolates from Yunnan, Hubei, Sichuan, Inner Mongolia and Xinjiang (Li Gen and Peng Kegao 1989) were observed by electron microscopy after purification. After purification, the nucleic acid of each BLU was analysed by SDS-PAGE with the international standard isolates as controls. After treatment with general disinfectants such as 1.5% methanol, 3% Na<sub>2</sub>CO<sub>3</sub>, 75% ethanol, 39% NaOH, 0.2% and 2% peracetic acid and ether, or being kept at 80°C for 15 minutes, isolate Y33F5 was inoculated to sheep into determine its characteristics and resistance to treatment.

## Passage, storage and activation detection

For infectivity tests we used healthy cross-breed sheep, aged 6 to 12 months, from a bluetongue-free area.

### Original virus

For passage tests, we used virus isolated in July 1979 from sheep with natural bluetongue, numbers 33 (Y33) and 35 (Y35). Two groups of three sheep each were inoculated subcutaneously with 5 mL of whole blood containing Y33 (passage 18) and Y55 (passage 5) respectively. Blood was collected 5 to 18 days post-infection and stored or inoculated into experimental animals.

To examine storage resistance, 12 sheep blood samples stored at 4°C were used to confirm infectivity. Except for one sheep inoculated with original blood from Y55, 22 sheep were inoculated with 5 mL of 12 samples from different passages, using two sheep per inoculum.

To analyse activity, we used virulent viruses Y226F10 and Y33-505F5 from sheep used for passaging. Two trials were conducted. In the first trial, 16 sheep (four groups of four) were inoculated with 5 mL of inoculum in dilutions of 10<sup>-1</sup>, 10<sup>-2</sup>, 10<sup>-3</sup> and 10<sup>-4</sup> (diluent was 5% glucose-saline). In the second trial, 12 sheep (four groups of three) were inoculated with 5 mL inoculum at the same dilutions as above but after three sets of washing with saline.

### Criteria for sheep experiments

All experimental animal were kept in isolation, their body temperature measured twice daily, and leucocytes measured every two days. Clinical signs were recorded daily for 14 days. All experimental sheep showing an elevated body temperature, a leucocyte decline of one-third and other clinical signs were scored as strong positives (++), while those with subclinical infection were scored as positive (+). The remaining sheep, with no changes in body temperature and leucocytes, were considered negatives (-). The infectious dose at 50% endpoint was calculated by standard methods.

## Results and Discussion

Most of the viruses examined were complete and spherical in shape, and unenveloped. The size of virions was uniform at 65-70 nm in diameter. There were no significant differences among isolates. The morphological appearance of bluetongue viruses could be of some diagnostic value, if seen in tissues or blood, but supplementary serological or biochemical tests are necessary to put them into their groups.

The bands of five isolates from SDS-PAGE were 3.3,3.1, which agreed with standards for bluetongue.

There were slight differences between strains but none between serotypes. SDS-PAGE was thus a reliable method to determine strain differences.

While 1.5% methanol, 3% lysol and exposure to 56°C did not kill the viruses, 75% ethanol, 3% Na<sub>2</sub>CO<sub>3</sub>, 3% NaOH, 0.2% and 2% peracetic acid and ether, or a temperature of 80°C for 15 minutes, effectively inactivated them (Table 1).

**Table 1.** Chemical resistance and physico-chemical properties of Chinese bluetongue strains.

Treatment of virus	No. of inoculated sheep	No. of sheep with blue-tongue	Incidence rate	Effective rate of treatment
3% NaOH	2	0	0/2	2/2
75% ethanol	4	0	0/4	4/4
2% peracetic acid	4	0	0/4	4/4
0.2% peracetic acid	4	0	0/4	4/4
3% carbolic acid	2	0	0/2	2/2
ether	4	0	0/4	4/4
3% lysol	2	1	1/2	1/2
3% Na <sub>2</sub> CO <sub>3</sub>	2	1	1/2	1/2
chloroform	2	1	1/2	1/2
56°C for 30 min	2	1	1/2	1/2
80°C for 15 min	4	0	0/4	4/4
1.5% methanol	2	2	2/2	0/2
Control (whole blood)	2	2	2/2	
Control (saline)	4	4	4/4	

Bluetongue strains from different passage levels induced typical clinical symptoms of bluetongue. The mortality of sheep caused by high passage virus was less in comparison to low passage virus. Strain Y33 is an obvious example. The appearance of other clinical signs such as swollen head and ears, erosion in nostrils, oedema and haemorrhage of the tongue and mouth mucosa declined as the passage level increased.

The duration of storage at 4°C was from 6 to 28 months. There was little difference between each passage in virulence value (Table 2). The virulence of isolates titrated in sheep gave an ID<sub>50</sub> for Y226F10 of 10<sup>2.25</sup>/5 mL and for Y-505F5 was 10<sup>2.75</sup>/5 mL (Table 3).

**Table 2.** Storage durability of Yunnan strains of bluetongue virus.

Strain and passage	Storage time (months)	Sheep inoculated	Clinical diagnosis (+/-)
Y-F247, 47, 57	28	2	++ ++
Y-F3-64, 46	26	2	++ ++
Y-F8-125, 315	18	2	+++
Y-F15-339, 348	18	2	++
Y-F16-459	10	2	++ ++
Y-F10-293	6	2	++
Y55-F3-457, 458	6	2	+++
Y55-F4-472, 479	10	2	++ ++
Y55-F2-207	9	2	++
Y55-F2-447	8	2	++
Y55 experimental inoculum	6	2	+++
Y55 experimental inoculum	18	1	++

**Table 3.** Infectivity of Yunnan virulent strain of bluetongue virus.

	Dilution	Inoculated animal
Y226F10	10 <sup>-1</sup>	4/4
	10 <sup>-2</sup>	4/4
	10 <sup>-3</sup>	1/4
	10 <sup>-4</sup>	0/4
	ID <sub>50</sub>	10 <sup>2.5</sup> /5 mL (2 January 1981)
Y505FS	10 <sup>-1</sup>	3/3
	10 <sup>-2</sup>	3/3
	10 <sup>-3</sup>	1/3
	10 <sup>-4</sup>	0/3
	ID <sub>50</sub>	10 <sup>2.75</sup> /5 mL (26 June 1982)

## References

- Alstad, A.D., Burger, D., Frank, F.W., McCain, C.S., Moll, T. and Stauber, E.S. 1977. Localization of bluetongue virus in red blood cells of experimentally infected sheep. *Proceedings of the American Association of Veterinary Laboratory Animal Diagnosticians*, 273-290.
- Bowne, J.G. 1971. Bluetongue disease. In: Brandy, C.A. and Cornelius, C.E., ed., *Advances in Veterinary Science and Comparative Medicine*, 4-5, 12-14 and 35.

- Els, H.J. and Verwoerd, D.W. 1969. Morphology of bluetongue virus. *Virology* 38, 213–219.
- Fernandes, M.V. 1959. Cytopathic effects of lamb tissues in vitro. *Texas Reports on Biology and Medicine*, 17, 94–105.
- Guo Zaijun, Hao Jucai, Chen Jianguo, Jian Zuoming, Li Zhihua, Zhang Khaili, Hu Yuling, Li Gen and Pu Long. 1989. Report of bluetongue disease survey in Bayannur Meng, Inner Mongolia. *Yunnan Animal Husbandry and Veterinary Journal*, 4, 53–56.
- Klontz, G.W., Svehag, S.E. and Gorham, J.R. 1962. A study by the agar diffusion of precipitating antibody directed against bluetongue virus and its relation to homeotypic antibody. *Arkiv für die Gesamte Virusforschung*, 12, 259–268.
- Li Gen and Peng Kegao. 1989. Adaptation of bluetongue virus to BHK21 cell and screening of cells for sensitivity. *Yunnan Animal Husbandry and Veterinary Journal*, 4, 29–30.
- Lin Lihui, Huang Qiaoling, Kang Changfeng, Zhong Liying, Li Ping, Li Bing and Song Hang. 1989. Isolation of bluetongue virus and a serological survey in Sichuan Province. *Yunnan Animal Husbandry and Veterinary Journal*, 4, 57–60.
- Li Zhihua, Zhang Khaili, Hu Yuling, Li Gen, Wu Dexing and Peng Kegao. 1989. Isolation and identification of bluetongue virus from sheep in Hubei Province. *Yunnan Animal Husbandry and Veterinary Journal*, 4, 49–52.
- Neitz, W.O. 1948. Immunological studies on bluetongue in sheep. *Onderstepoort Journal of Veterinary Science and Animal Industry*, 23, 93–136.
- Qin Qiyang, Tai Zhengguo, Wan Lijin, Luo Zhengqi, Nu Edan, Lin Hanlang and Liu Yifu. 1991. Epidemiological survey of bluetongue and the isolation and identification of bluetongue virus in Xinjiang. *Yunnan Animal Husbandry and Veterinary Journal*, 3, 79–80.
- Verwoerd, D.W. 1969. Purification and characterization of bluetongue virus. *Virology*, 38, 203–212.
- Zhang Nianzu, Zhang Khaili, Li Zhihua, Shanyu Naishun, Hu Yuling, Li Gen, Zhao Kun, Zhou Fuzhong and Xu Wenzhen. 1989a. Determination of bluetongue virus resistance to conventional disinfectant chemicals and different temperatures. *Yunnan Animal Husbandry and Veterinary Journal*, 4, 39–40.
- 1989b. Investigation and study of bluetongue disease of sheep in Yunnan, China. *Yunnan Animal Husbandry and Veterinary Journal*, 4, 3–12.

# Identification of Local Chinese Strains of Bluetongue Virus to Serotype

Zhang Nianzu, Peng Kegao, Li Zhihua, Zhang Khaili, Li Huachun, Hu Yuling, Li Gen, Zhang Fuqiang, Li Xinrong and Ben Jin\*

## Abstract

Since the first outbreak of bluetongue disease in Yunnan in 1979, bluetongue viruses (BLU) have been isolated from sheep in Yunnan, Hubei, Sichuan, Anhui, Shandong and Shanxi Provinces, from goats in Xinjiang and Inner Mongolia, and from cattle in Gansu. These virus strains were identified to group by agar gel immunodiffusion (AGID), immunofluorescence (IF) and agar gel electrophoresis. Eight of the Chinese strains were identified to serotype by microneutralisation tests. These showed that strains Sx1 from Yuncheng County in Shanxi, Sx2 from Jiansu County in Shanxi, Y863P 12 from Yunnan, X27 from Xinjiang and Yc from *Culicoides* trapped in the animal laboratory in Kunming were serotype BLU1. Both WP7 from Hubei and SWP7 from Sichuan Province were BLU16. Early results indicate that NMP11 from Inner Mongolia might be BLU17 but further confirmatory tests are required.

BLUETONGUE epidemic sites were found in four provinces of China and AGID-positive animals in 29 provinces. Bluetongue virus (BLU) was isolated after the first outbreak of disease in Yunnan Province (Zhang Nianzu et al. 1993). Initial reports identified at least four serotypes existing in China using the tests (AGID, immunofluorescence and RNA-PAGE) available at that time (Zhang Nianzu et al. 1991). This paper describes the identification of local isolates from different provinces of China by microneutralisation tests.

## Materials and Methods

### Isolates

Eight isolates and specimens were tested:

- Y863P 12 from Yunnan (isolated from a sheep in 1979)
- WP7 from Hubei (isolated from a sheep in 1988)
- Sx 2 from Shanxi (isolated from a sheep in 1994)

- Sx 1 from Shanxi (BHK21 cell culture of blood collected from a sick sheep in 1993)
- SWP 9 from Sichuan (isolated from a sheep in 1988)
- X 27 from Xinjiang (isolated from a goat in 1989)
- NMP 11 from Inner Mongolia (isolated from a goat in 1989)
- Yc from Yunnan (isolated from *Culicoides* in 1993).

### Antisera

Four sets of antisera were used:

- Standard sera of BLU1-24 (from Veterinary Research Institute, Onderstepoort, South Africa, provided by the China-Australia Bluetongue Project), reconstituted with distilled water then stored at  $-20^{\circ}\text{C}$ .
- Negative control, prepared from newborn calf serum.
- Sx 1 positive control sera, prepared from the blood of Shanxi bluetongue-diseased sheep inoculated into experimental sheep in this laboratory.
- Standard positive controls, BLU1, 15, 20 and 23 provided by Berrimah Agricultural Research Centre, Australia.

---

\* Yunnan Tropical and Subtropical Animal Virus Diseases Laboratory, Jindian 650224, Kunming, People's Republic of China.



## Procedure

1. Microneutralisation: according to the standard protocol of Gard and Kirkland (1993).
2. Primary screening of serum: standard positive sera diluted with PBS at 1:20, then sera tested, and any positive sera selected for titration to identify serotype.
3. Outline of identification procedure: positive sera serially diluted at 1:1; Sx 1 serum diluted at 1:5 as the initial concentration, then serially diluted at 1:1; reaction volume of 25  $\mu$ L; control plus 25  $\mu$ L; tested serum plus 100  $\mu$ L cell (concentration at  $2.5 \times 10^{-5}$ /mL); reading control as 100 TCID<sub>50</sub>. Plates read daily, and wells with any cytopathic effect (CPE) recorded as positive, those without CPE as negative.

## Results

The results for most of the isolates were interpreted easily (Table 1; positive results only). Isolates Y863, Sx1, Sx2, Yc, and X27 were clearly BLU1 as they reacted strongly to the BLU1 standard control. Isolates WP7 and SWP 9 were strongly neutralised by standard BLU16 and BLU3. There was a very slight cross-reaction with BLU13 but no neutralisation with BLU1-12, BLU14-15 and BLU17-24. However, when titrated there was a four-fold greater titre with the antiserum to BLU16. Isolate NMP11 was strongly neutralised by BLU17 antiserum, partially cross-neutralised by BLU20 and 22 antisera and very slightly inhibited by BLU4 and 11.

## Discussion

Our results support the conclusions of primary screening and serum surveys, that is, that at least two separate serotypes are circulating in China. Five isolates from Shanxi, Yunnan and Xinjiang are BLU1.

Isolates SWP9 (Sichuan) and WP7 (Hubei) are BLU16 (significant neutralisation with BLU16 standard control, and lower partial cross reaction with BLU13). The serotype of isolate NMP11 needs further confirmation, as there are contradictory results from primary screening (strong reaction with BLU17) and from microneutralisation survey tests (no BLU17 antibodies detected in the area). Thus NMP11 is only provisionally identified as BLU17.

All results basically confirmed conclusions from the earlier animal cross-protection experiments, serum surveys in the area of origin and VP2 polymerase chain reaction (PCR) tests. We therefore conclude that the dominant BLU serotypes in China are BLU1 and BLU16. The isolate from Inner Mongolia might be BLU17, to be confirmed if antibodies are found in ruminants there.

## Acknowledgments

Dr B. Erasmus of the World Bluetongue Reference Centre, Onderstepoort, South Africa, provided the standard bluetongue antisera. Dr L.F. Melville provided the Australian antisera.

## References

- Gard, G.P. and Kirkland, P.D. 1993. Bluetongue virology and serology. *Australian Standard Diagnostic Techniques for Animal Diseases*. Canberra, Australia, 10-12.
- Zhang Nianzu, Zhang Khaili and Li Zhihua 1991. Cross-protection tests for bluetongue. *Yunnan Animal Husbandry and Veterinary Journal*, 3, 30-32.
- Zhang Nianzu, Zhang Khaili, Li Zhihua, Hu Yuling, Li Gen, Peng Kegao, Wu Dexing and Li Huachun. 1993. Bluetongue in China. In: Uren, M.F. and Kay, B.H. ed., *Arbovirus research in Australia*. Proceedings 6th Symposium. CSIRO/Queensland Institute of Medical Research, Brisbane, 192-193.

**Table 1.** Titration of Chinese isolates by microneutralisation test (titre of antisera that neutralised virus at TCID<sub>50</sub>).

Isolates	Standard positive sera titres										
	1 Au <sup>a</sup>	1 SA <sup>b</sup>	3 SA	4	11	15 Au	16 SA	17 SA	20	23	Sx 1 sera
Sx2	64	80	-	-	-	-	-	-	-	-	20
Sx1	8	40	-	-	-	-	-	-	-	-	40
Yc	16	20	-	-	-	-	-	-	-	-	-
Y863P12	-	40	-	-	-	-	-	-	-	-	-
SWP9	-	-	20	-	-	-	80	-	-	-	-
WP7	-	-	20	-	-	-	80	-	-	-	-
NMP11	-	-	-	20	20	-	-	40	20	-	-
X27	-	20	-	-	-	-	-	-	-	-	-

<sup>a</sup>Au Australia antisera

<sup>b</sup>SA South African antisera

NB. All other antisera produced no neutralisation.

# Regular Changes in Immunomorphology of Sheep Given Live Attenuated and Inactivated Bluetongue Vaccines

Chu Guifang, Wu Donglai, Yin Xunnan and Qu Xiangdong\*

## *Abstract*

Five groups of sheep were given inactivated bluetongue vaccine and four groups attenuated live virus vaccine, using 148 sheep in all. For these tests, Hubei inactive vaccine and Sichuan chicken embryo attenuated vaccine were chosen from nine vaccines as they were considered safe and effective. Inactive vaccine produced protection at 40 days post inoculation and attenuated vaccine at 20 days. The immune response to bluetongue disease was both humoral and cellular. Observations included immuno-histochemistry, histology, cellular chemistry and electron microscopy. No antigen was detected in the target cells of vaccinated sheep. T and B cells in the immune system and peripheral blood peaked at the same time. Sheep mounted an immune response immediately after challenge. No immune sheep challenged after vaccination had antigens in the target cells. Neither T nor B cells obviously increased or decreased immediately after challenge or as a delayed response.

---

\* Harbin Veterinary Research Institute, Chinese Academy of Agricultural Sciences, 101 Maduan Street, Harbin 150001, People's Republic of China.

# The Pathogenicity of Chinese Bluetongue Virus in Sheep, Deer and Goats

Zhang Khaili\*

## *Abstract*

Buffalo, cattle and goats were inoculated with whole blood from diseased sheep which had been inoculated with the Yunnan strain of bluetongue virus serotype 1 (BLU1). Experimental animals showed a rise in temperature of about 0.5–1.2°C after 5–7 days and the number of leucocytes decreased by 30–50%. No clinical signs were observed. The same virus was used to inoculate musk deer (*Moschus moschiferus*), sika deer (*Cervus nippon*) and fallow deer (*Dama dama*). There was no rise in body temperature in these animals but the number of leucocytes decreased by 30–50% and some deer died 2–4 days after inoculation, although others survived. The main clinical signs included haemorrhages of the digestive tract, intestinal mucosa and lymph glands, liver and kidney. There was also necrosis and shedding of intestinal mucosa. Other clinical signs, observed in two deer, were haemorrhage and erosion of external nares plus shedding of mucosa in the nasal cavity. When inoculated into sheep, blood from these deer caused classic bluetongue disease.

---

\* Yunnan Tropical and Subtropical Animal Virus Diseases  
Laboratory, Jindian 650224, Kunming, People's Republic of China.

# Identification of Monoclonal Antibody-defined Epitopes Validates the Bluetongue Competitive ELISA

B.T. Eaton, Wang Linfa and J.R. White\*

## Abstract

The internationally recognised competitive enzyme linked immunosorbent assay (cELISA) for bluetongue relies on the ability of antibodies in sera to inhibit the binding of a mouse monoclonal antibody (MAB) to bluetongue virus (BLU) antigen. Suitable MABs have been generated in several laboratories. MAB E9, in the Australian cELISA, reacts with the vast majority of BLU serotypes and its binding to BLU antigen is inhibited strongly by antisera to all Australian serotypes except BLU15. MAB E9 does not bind to BLU15. Mapping studies reveal that the E9 epitope lies between amino acids 30 and 38 of the major core protein VP7. Amino acids 21–54 are conserved in all sequenced VP7 genes and the location of epitope E9 validates use of MABs to this region not only in cELISA but also as serogroup-specific reagents for virus detection. MAB E9 reacts with a hybrid molecule containing amino acids 1–76 of BLU15 and amino acids 77–349 of BLU1 VP7. Thus conformation of the E9 epitope depends on other parts of the molecule. The chimeric BLU1/BLU15 VP7 antigen will be tested for its ability to detect antibodies to BLU15. Field and experimental antisera to BLU compete with MABs to the amino terminal domain of VP7. This part of the protein therefore is highly immunogenic and an ideal region with which to detect anti-BLU antibodies. Epitope topography in the amino-terminal portion of VP7 is retained in virus and core particles, baculovirus-expressed core and virus-like particles and in VP7 expressed in vaccinia and yeast. All such preparations may be used as antigens in the bluetongue cELISA.

ANTI-BLUETONGUE antibody in infected animals can be detected by a variety of tests. Complement fixation and agar gel immunodiffusion (AGID) tests (Boulanger and Frank 1975; Afshar et al. 1989) were popular before the development of a competitive enzyme linked immunosorbent assay (cELISA; Anderson 1984). The cELISA rapidly replaced the other two methods, which were cumbersome, reagent expensive and inadequate because they could not differentiate antibodies to BLU from those to other cross-reacting viruses (such as the epizootic hemorrhagic disease of deer viruses). The development of cELISA tests was made possible by the use of monoclonal antibodies (MAB) specific for BLU. While the

first MAB-based cELISA was described by Anderson (1984), there have been several others since then, most notably those of Lunt et al. (1988) and Reddington et al. (1991).

From 1989 to 1992 several laboratories around the world compared the existing test protocols and reagents, the key variables in the tests being antigen and MAB. Antigens examined included virus and virus proteins in infected cell lysates (Anderson 1984; Lunt et al. 1988), sodium dodecyl sulfate-denatured viruses (Polkinghorne et al. 1992) and yeast-expressed (Martyn et al. 1990) and baculovirus-expressed (Oldfield et al. 1990) VP7 core protein. The trials involved laboratories in Australia, U.K., Canada and USA and the results (Afshar et al. 1992) were compared at a meeting in Vienna in October 1990 and presented at the bluetongue meeting at Office International des Epizooties, Paris in 1992

\* Australian Animal Health Laboratory, PO Bag 24, Geelong, Victoria 3220, Australia.

(Jeggo et al. 1992). A summary of the method is given below.

The key reagent in cELISA is the MAb because it brings specificity to the test. Examples of MAbs used in cELISA are 3-17-A3 (Anderson 1984) and 20E9 (Lunt et al. 1988). In the cELISA, antibodies in test sera compete with the MAb for binding to antigen. In this paper we describe experiments to map the epitope to which MAb 20E9 binds. Our results validate the use of this, and other similar MAbs, in a cELISA for bluetongue.

## cELISA Methodology

The following procedure for cELISA has been standardised after comparative studies in several international laboratories. Microtitre plates (96-well) are coated at 4°C overnight or 37°C for 1 hour, with 50–100 mL of antigen (tissue culture-derived sonicated virus (Anderson 1984); SDS-treated virus (Polkinghorne et al. 1992); or recombinant VP7 (Oldfield et al. 1990; Martyn et al. 1990) diluted in 0.05 M carbonate buffer, pH 9.6).

Plates are washed five times with PBST (0.01 M phosphate buffered saline containing 0.05% or 0.1% Tween 20, pH 7.2). Test sera are added (50 mL) in duplicate at a single dilution, either 1/5 (Afshar et al. 1989) or 1/10 (Lunt et al. 1988) in PBST containing 3% bovine serum albumen (BSA). Immediately into each well is placed 50 mL of a predetermined dilution of MAb diluted in PBST-BSA. MAb control wells contain diluent buffer in place of test sera. Plates are incubated for 1 hour at 37°C, or 3 hours at 25°C, with continuous shaking. After washing, wells are filled with 100 mL of an appropriate dilution of horseradish peroxidase-labelled rabbit anti-mouse IgG in PBST containing 2% normal bovine serum. Following incubation for 1 hour at 37°C, the conjugate solution is discarded and plates washed five times using phosphate buffered saline (PBS) without Tween. Wells are filled with 100 mL substrate solution containing 1.0 mM ABTS-4 mM H<sub>2</sub>O<sub>2</sub> in 50 mM sodium citrate, pH 4.0 and plates shaken at 25°C for 30 minutes. (Other substrates may be used and the reaction continued with shaking for an appropriate time to permit colour development.) The reaction is stopped by adding a stopping reagent such as sodium azide.

After blanking the ELISA reader on wells containing substrate and stopper, the optical density (OD) values are measured at 414 nm. Results, expressed as percent inhibition, are derived from the mean OD values for each sample using the formula

$$\% \text{ inhibition} = 100 - \left[ \frac{\text{Mean OD test sample}}{\text{Mean OD MAb control}} \times 100 \right]$$

Percentage inhibition values greater than 40% or 50% are considered positive. Results of test sera duplicates may vary as long as they do not lie either side of the chosen inhibition value. On each plate, strong and weak positive sera and a negative serum should be included. The weak positive should give 60–80% inhibition and the negative less than 40%.

## Results

MAb E9, raised in mice against SDS-denatured BLU1, reacts in ELISA with yeast and vaccinia virus-expressed VP7 of BLU1 and with lysates of cells infected with all serotypes of BLU except BLU15 (Eaton et al. 1991). VP7 is the major core protein of the BLU virus (Huismans and Van Dijk 1990). Immuno-gold electron microscopy indicates that MAb E9 binds to intact virus particles, indicating that a portion of the underlying core particle is accessible at the virus surface. The E9 epitope is conformational: although it survives denaturation of VP7 with SDS, it is destroyed by heat and cannot be detected by western blotting. It is sensitive to reduction (by dithiothreitol) and acetylation (by iodoacetamide), suggesting a location near the only disulfide bond linking cysteine residues at amino acids 15 and 65 (Eaton et al. 1991). MAb E9 reacted with the amino terminal half of the VP7 expressed in bacteria. Attempts to map its position using truncated VP7 peptides as fusion peptides in *E. coli* failed because the products were insoluble and SDS and heat, needed for solubilisation, destroyed the epitope (Eaton et al. 1991).

We have made considerable progress in recent years in mapping bluetongue virus epitopes particularly using phage display technology (Du Plessis et al. 1994; Wang et al. 1995). Three different approaches have been used to map the E9 epitope used in the cELISA (Wang et al. 1994b).

MAb E9 does not react with BLU15 VP7. However, a hybrid molecule containing amino acids 1–76 of BLU1 VP7 linked to amino acids 77–349 of BLU15 was capable of reacting with MAb E9. The hybrid gene was cloned into the T7 RNA polymerase-directed expression vector pET-5b and transcribed and translated *in vitro*. MAb E9 was added to the mix followed by immunobeads coated with rabbit anti-mouse antibody. The immuno-captured material was analysed on SDS gels. Chimeric BLU1/15 VP7, but not BLU15 VP7, was captured by MAb E9. Thus the E9 epitope is present in the first 76 amino acids of the VP7 molecule.

A second approach made use of another anti-VP7 MAb (1AA4, provided by Dr J. Meecham, ABADRL, Laramie, Wyoming, USA) which competed with MAb E9 for binding to yeast-expressed

VP7 of BLU1. Unlike MAb E9, MAb 1AA4 reacted with VP7 in western blots. Truncated VP7 peptides of BLU1 VP7 were made as C-terminal fusion proteins to pGEX expressed glutathione S-transferase. Western blots indicated that MAb 1AA4 reacted with the first 68 amino acids of VP7.

The third approach used epitope scanning by competition with short synthetic peptides. Five peptides were made which covered amino acids 11–29, 20–29, 30–47, 39–47 and 48–63 of BLU1. Binding of MAb E9 to yeast-expressed or viral VP7 was reduced by 87% by the peptide containing amino acids 30–47. The peptide containing amino acids 39 to 47 did not inhibit. These data suggest that the E9 epitope lies within amino acids 30–38. The peptide containing amino acids 48–63 inhibited MAb 1AA4 binding by 90%.

The region 39–47 is conserved across all BLU serotypes, which confirms the usefulness of a MAb which binds in that region as a serogroup-specific diagnostic reagent.

## Discussion

Recent cryo-electron microscopic and X-ray crystallographic data have indicated that VP7 exists in virus core particles as a trimer (Basak et al. 1992; Grimes et al. 1995). Topographic studies (Hewat et al. 1992; Hyatt and Eaton 1988) have confirmed that the molecules are arranged with at least some of them having their amino termini accessible from the outside of core particles. Many MAbs generated to VP7 from several sources compete with MAb E9 and therefore bind to the exposed part of the VP7 trimer (Wang et al. 1992). As field ovine and bovine sera, and experimental rabbit, ovine, murine and bovine polyclonal antisera to all BLU serotypes contain antibodies that compete with MAbs to the amino terminal domain, this part of the protein appears highly immunogenic in all species tested.

The amino acid sequence 21 to 54 is absolutely conserved in all sequenced BLU VP7 genes, including BLU15 (Wang et al. 1994a) and the E9 epitope is located in the middle of this conserved region (Iwata et al. 1992). The failure of MAb E9 to bind to BLU15 VP7 suggests that the sequence of the binding site alone is not sufficient to provide a functional epitope for the MAb. Since the BLU1/15 VP7 chimera was able to bind MAb E9, residues close to the binding site are probably critical in maintaining conformation of a functional binding site.

Although the cELISA used at the Australian Animal Health Laboratory (AAHL) is robust and highly effective, it suffers one minor disadvantage in that it detects anti-BLU15 antibodies with low efficiency, presumably because antisera to BLU15 lack antibod-

ies to the E9 epitope. The failure of cELISA to detect antibodies to all BLU serotypes with high efficiency is not unique to the AAHL test. In the cELISA described by Anderson (1984), antibodies to BLU19 were detected with lower efficiency than those to other serotypes. Current data suggest that the efficiency of detection of anti-BLU15 antibodies in our cELISA can be improved to some extent if antigen preparations other than yeast-expressed VP7 are used in the test. The ability of anti-BLU15 antiserum to compete with MAb E9, albeit weakly, may be due to the fact that, although the E9 epitope is not shared between BLU15 and the BLU1 antigen used in the test, these viruses may have other epitopes in common. Antibodies to shared epitopes in BLU15 antisera may be able to inhibit sterically the binding of MAb E9 to BLU1 antigen. We are currently investigating the possibility of using the chimeric BLU1/15 VP7 molecule as an antigen in the cELISA.

At present, the greatest need in bluetongue diagnosis worldwide is for alternative methods to determine the serotype specificity of antibodies in test sera. Currently, serotype-specific antibodies are detected in neutralisation tests which are labour intensive, time consuming, unsuitable for analysis of large numbers of sera and which, because live virus is used, may have to be done in secure laboratories. At first sight an attractive option would be to develop cELISA procedures in which antibodies in test sera compete with serotype-specific MAbs for binding to antigen. The difficulty with such an approach is the requirement that the MAb must bind only to its homologous serotype. Unfortunately, the extreme paucity of MAbs that display serotype-specific binding suggests that it will be difficult to generate MAbs that bind to only one serotype. Indeed, MAbs that neutralise one serotype may not only neutralise other serotypes but may also bind to, and not neutralise, many heterologous serotypes (Ristow et al. 1988; White and Eaton 1990).

## References

- Afshar, A., Eaton, B.T., Wright, P.F., Pearson, J.E., Anderson, J., Jeggo, M. and Trotter, H. 1992. Competitive ELISA for serodiagnosis of bluetongue: evaluation of group-specific monoclonal antibodies and expressed VP7 antigen. *Journal of Veterinary Diagnostic Investigation*, 4, 231–237.
- Afshar, A., Thomas, F.C., Wright, P.F., Shapiro, J.L. and Anderson, J. 1989. Comparison of competitive ELISA, indirect ELISA and standard AGID tests for detecting bluetongue virus antibodies in cattle and sheep. *Veterinary Record*, 124, 136–141.
- Anderson, J. 1984. Use of monoclonal antibody in a blocking ELISA to detect group specific antibodies to bluetongue virus. *Journal of Immunological Methods*, 74, 139–149.

- Basak, A.K., Stuart, D.I. and Roy, P. 1992. Preliminary crystallographic study of bluetongue virus capsid protein, VP7. *Journal of Molecular Biology*, 228, 687-689.
- Boulanger, P. and Frank, J.F. 1975. Serological methods in the diagnosis of bluetongue. *Australian Journal of Veterinary Research*, 51, 185-189.
- Du Plessis, D.H., Wang, L.F., Jordaan, F.A. and Eaton, B.T. 1994. Fine mapping of a continuous epitope on VP7 of bluetongue virus using overlapping synthetic peptides and a random epitope library. *Virology*, 198, 346-349.
- Eaton, B.T., Gould, A.R., Hyatt, A.D., Coupar, B.E.H., Martyn, J.C. and White, J.R. 1991. A bluetongue serogroup reactive epitope in the amino terminal portion of the major core protein VP7 is accessible on the surface of bluetongue virus particles. *Virology*, 180, 687-696.
- Grimes, J., Basak, A.K., Roy, P. and Stuart, D. 1995. The crystal structure of bluetongue VP7. *Nature*, 373, 167-170.
- Hewat, E.A., Booth, T.F., Loudon, P.T. and Roy, P. 1992. Three dimensional reconstruction of baculovirus expressed bluetongue virus core-like particles by cryo-electron microscopy. *Virology*, 189, 10-20.
- Huismans, H. and Van Dijk, A.A. 1990. Bluetongue virus structural components. *Current Topics in Microbiology and Immunology*, 162, 21-41.
- Hyatt, A.D. and Eaton, B.T. 1988. Ultrastructural distribution of the major capsid proteins within bluetongue virus and infected cells. *Journal of General Virology*, 69, 805-815.
- Iwata, H., Yamagawa, M. and Roy, P. 1992. Evolutionary relationships among the gnat-transmitted orbiviruses that cause african horse sickness, bluetongue, and epizootic hemorrhagic disease as evidenced by their capsid protein sequences. *Virology*, 191, 251-261.
- Jeggo, M., Wright, P., Anderson, J., Eaton, B., Afshar, A., Pearson, J., Kirkland, P. and Ozawa, Y. 1992. Review of the IAEA Meeting in Vienna on standardization of the competitive ELISA test and reagents. In: Walton, T.E. and Osburn, B.I., ed., *Bluetongue, African horse sickness and related orbiviruses*. Proceedings 2nd International Symposium. CRC Press, Boca Raton, 547-560.
- Lunt, R.A., White, J.R. and Blacksell, S.D. 1988. Evaluation of a monoclonal antibody blocking ELISA for the detection of group-specific antibodies to bluetongue virus in experimental and field sera. *Journal of General Virology*, 69, 2729-2740.
- Martyn, C.J., Gould, A.R. and Eaton, B.T. 1990. High level expression of the major core protein VP7 and the non-structural protein NS3 of bluetongue virus in yeast. Use of expressed VP7 as a diagnostic group-reactive antigen in a blocking ELISA. *Virus Research*, 18, 165-178.
- Oldfield, S., Adachi, A., Urakawa, T., Hirasawa, T. and Roy, P. 1990. Purification and characterization of the major group-specific core antigen VP7 of bluetongue virus synthesized by a recombinant baculovirus. *Journal of General Virology*, 71, 11 2649-2656.
- Polkinghorne, I., Crameri, G.S., Wu, M.J. and Eaton, B.T. 1992. Use of bluetongue viral and yeast-expressed antigens in the analysis of sera by competitive ELISA. In: Walton, T.E. and Osburn, B.I., ed., *Bluetongue, African horse sickness and related orbiviruses*. Proceedings 2nd International Symposium. CRC Press, Boca Raton, 609-616.
- Reddington, J.J., Reddington, G.M. and MacLachlan, N.J. 1991. A competitive ELISA for detection of antibodies to the group antigen of bluetongue virus. *Journal of Veterinary Diagnostic Investigation*, 3, 144-147.
- Ristow, S., Leenderstein, L., Gorham, J. and Yilma, T. 1988. Identification of a neutralising epitope shared by bluetongue virus serotypes 2 and 13. *Journal of Virology*, 62, 2502-2504.
- Wang, L.F., Du Plessis, D.H., White, J.R., Hyatt, A.D. and Eaton, B.T. 1995. Use of a gene-targeted phage display random epitope library to map an antigenic determinant on the bluetongue virus outer capsid protein VP5. *Journal of Immunological Methods*, 178, 1-12.
- Wang, L.F., Gould, A.R., Hyatt, A.D. and Eaton, B.T. 1992. Nature and location of epitopes utilized in competitive ELISA to detect bluetongue virus antibodies. *Bluetongue, African horse sickness and related orbiviruses*. In: Walton, T.E. and Osburn, B.I., ed., *Bluetongue, African horse sickness and related orbiviruses*. Proceedings 2nd International Symposium. CRC Press, Boca Raton, 596-603.
- Wang, L.F., Kattenbelt, J.A., Gould, A.R., Pritchard, L.I., Crameri, G.S. and Eaton, B.T. 1994a. Major core protein VP7 of Australian bluetongue virus serotype 15: sequence and antigenicity divergence from other BTV serotypes. *Journal of General Virology*, 75, 2421-2425.
- Wang, L.F., Scanlon, D.B., Kattenbelt, J.A., Meecham, J.O. and Eaton, B.T. 1994b. Fine mapping of a surface-accessible, immunodominant site on the bluetongue virus major core protein VP7. *Virology*, 204, 811-814.
- White, J.R. and Eaton, B.T. 1990. Conformation of the VP2 protein of bluetongue virus (BTV) determines the involvement in virus neutralisation of highly conserved epitopes within the BTV serogroup. *Journal of General Virology*, 71, 1325-1332.

# Comparison of Competitive ELISA and Agar Gel Immunodiffusion Tests to Detect Bluetongue Antibodies in Ruminants in China

Ben Jin\*, Li Zhihua\*, Li Huachun\*, L.F. Melville<sup>†</sup>, N.T. Hunt<sup>†</sup>, Li Xinrong\*, Zhang Fuqiang\* and Zhang Nianzu\*<sup>1</sup>

## Abstract

The agar gel immunodiffusion test (AGID) has been widely used as a bluetongue group antigen test. The competitive enzyme linked immunosorbent assay (cELISA) has been established for a few years and has become a recognised technique for the same purpose. Serum samples tested by AGID were also tested by cELISA. The capture antigen for the cELISA was the expressed yeast VP7 of BLU1. The AGID used antigen prepared from BLU1 isolated in Yunnan. The cELISA test used a monoclonal antibody competing with positive serum to bind the VP7. The AGID test used a reference serum produced in sheep by inoculation of homologous BLU1. Tests of 560 samples from goats, sheep and cattle showed that 85.4% of results were identical: however, 75 sera that showed positive in the cELISA were negative in the AGID, while seven samples positive in the AGID were negative in the cELISA. These results suggest that the cELISA may be more sensitive than AGID in the detection of bluetongue antibodies.

AGAR gel immunodiffusion (AGID) was the earliest method used in China for serological surveys of bluetongue antibody. Zhang Nianzu et al. (1989c) first found bluetongue disease in China in Yunnan in 1979 and developed the AGID to study bluetongue (BLU) epidemiology (Zhang Nianzu et al. 1989b). The first use of the enzyme linked immunosorbent assay (ELISA) for bluetongue research in China was at the Institute of Animal Quarantine, Ministry of Agriculture, Qingdao. The ELISA was also used at the Yunnan Institute of Animal Husbandry and Veterinary Medicine to select monoclonal antibody (MAb) for BLU research by Wu Dexing and Zhang Khaili (1991). To improve the sensitivity and specificity of the test for BLU, a competitive ELISA (cELISA) was developed using a MAb for the BLU group-specific antigen VP7.

## Materials and Methods

Five-hundred-and-sixty serum samples were tested from goats, sheep and cattle. Some of these were collected as part of a serological survey and some were from sentinel herds in Yunnan (Fig. 1) established by Li Huachun et al. (these Proceedings) and others from Inner Mongolia (Fig. 2).

The cELISA method was based on the method of Lunt et al. (1988) and Martyn et al. (1990). Tests were performed with TropBio ELISA Bluetongue Kits (Tropical Biotechnology Pty Ltd, James Cook University, Townsville, Australia).

The soluble antigen and reference sera were made as described by Zhang Nianzu et al. (1989a). Procedures for the AGID tests for BLU-antibody followed those established by Yunnan Institute of Animal Husbandry and Veterinary Medicine (Anon. 1989).

## Results

One-hundred-and thirty-nine samples were positive in both tests, while 339 samples were negative in both tests (Table 1). In the cELISA, 214 (38.2%) samples were positive while 146 (24.1%) samples

\* Yunnan Tropical and Subtropical Animal Virus Diseases Laboratory, Jindian 650224, Kunming, People's Republic of China.

<sup>†</sup> Department of Primary Industry and Fisheries, Berrimah Agricultural Research Centre, PO Box 79, Berrimah, Darwin, Northern Territory 0828, Australia.

<sup>1</sup> Author for correspondence.



were positive in the AGID test. Different results in the two tests occurred for 82 samples: 75 were positive in the cELISA but negative by AGID while seven samples were positive in the AGID but negative by cELISA.

ming; 19/80 from Yiliang; 12/81 from Lunan; 23/35, from Shizong; and 52/80 from Eshan. In Yunnan, the cELISA positive rate for cattle was 177/273 while the rate for sheep and goats was 10/257. In Inner Mongolia, 27 of 30 goats were cELISA positive. Some of these results are summarised in Table 2.

**Table 1.** Comparison of cELISA/AGID serology.

	cELISA (+)	cELISA (-)	Total
AGID (+)	139	7	146
AGID (-)	75	339	414
Total	214	346	560

## Discussion

This study suggests that the cELISA is more sensitive than AGID in detecting bluetongue antibodies. The major core-protein of BLU, VP7, is the serogroup-specific antigen. The binding of monoclonal antibody with VP7 is inhibited by a small amount of antibody to bluetongue viruses in the sera. Detection of antibody binding to VP7 also reduces the possibility of non-specific reaction giving a more specific result with the cELISA than the AGID test.

Animals infected by BLU produce antibodies which decline over time unless the animals are reinfected with another serotype. The reduced concentration of antibody may be insufficient for detection by AGID but may be detected by the more sensitive cELISA. This may explain why 75 samples were positive in cELISA but negative in AGID.

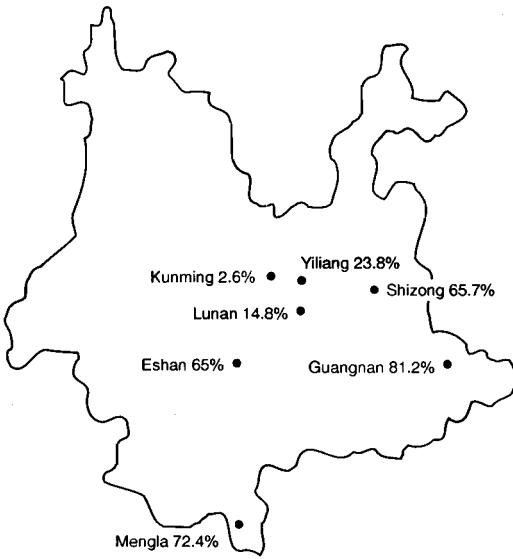

**Figure 1.** The cELISA positive rate of BLU-antibody in Yunnan.

The cELISA positive rate for sera was 21/29 from Mengla; 56/69 from Guangnan; 21/56 from Kun-

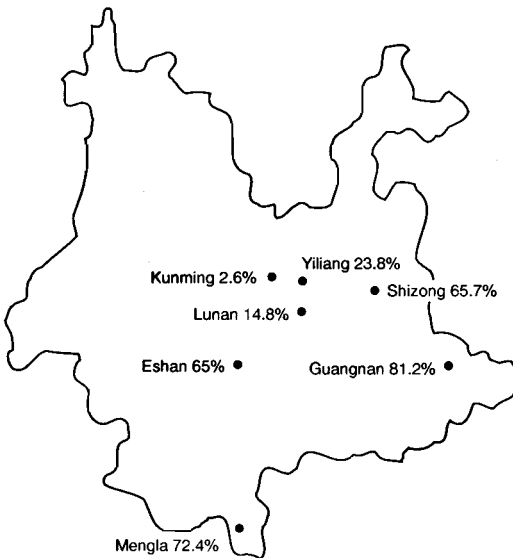

**Figure 2.** The sites of samples collected in China.

**Table 2.** Comparison of cELISA/AGID results on samples collected from 1992-95.

Place	Animals	AGID+	cELISA+	AGID+/ cELISA-	cELISA+/ AGID-	AGID+/ cELISA+
Yiliang	goats	2/40	2/40	0	0	2
	cattle	10/40	17/40	1	8	9
Lunan	goats	2/61	3/61	0	1	2
	cattle	1/20	9/20	0	8	1
Shizong	goats	0/5	0/5	0	0	0
	cattle	14/30	23/30	1	10	13
Mengla	cattle	14/29	21/29	1	8	13

Orbiviruses, such as BLU and epizootic hemorrhagic disease virus (EHD), have group-antigens in common, and so can stimulate the host to produce antibodies which may be detected by the AGID for BLU antibody. The seven samples positive in the AGID but negative in the cELISA may be the result of infection with other orbiviruses.

The sera from Mengla and Guangnan (Fig. 1) showed high levels of BLU antibody. Mengla and Guangnan lie in the south and southeast of Yunnan respectively, in typical tropical and subtropical regions. In summer and autumn, the humid and hot climate is suitable for the maintenance of *Culicoides* midges, the BLU vector. In Kunming, 300 km from Guangnan and 500 km from Mengla, few ruminants have antibodies to bluetongue, suggesting little vector activity in Kunming. The geographic distribution of other survey and sentinel sites indicates a general decrease in prevalence from south to north and with increasing altitude.

In Yunnan Province, the cELISA positive rate was higher in cattle than in sheep or goats, indicating a possible vector preference for cattle. In contrast, the cELISA positive rate was 27/30 in goat samples from Inner Mongolia, while the serological survey results from the local veterinary station show very few cattle with BLU antibody. This may indicate a different preference by vectors in Inner Mongolia, or a different vector entirely.

As the seven samples that were AGID positive and cELISA negative included one goat from Inner Mongolia and six cattle from Yunnan, infection with other

related orbiviruses may be more likely to occur in cattle than in sheep or goats.

## References

- Anon. 1989. The rules of AGID tests. *Yunnan Animal Husbandry and Veterinary Medicine*, 4, 43-48.
- Lunt, R.A., White, J.R. and Blacksell, S.D. 1988. Evaluation of a monoclonal antibody blocking ELISA for the detection of group-specific antibodies to bluetongue in experimental and field sera. *Journal of General Virology*, 69, 2729-2740.
- Martyn, J.C., Gould, A.R. and Eaton, B.T. 1990. High level expression of the major core protein VP7 and the non-structural protein NS3 of bluetongue virus in yeast: use of expressed VP7 as a diagnostic, group-reactive antigen in a blocking ELISA. *Virus Research*, 18, 165-178.
- Wu Dexing and Zhang Khaili 1991. The ELISA test for screening bluetongue monoclonal antibodies. *Yunnan Animal Husbandry and Veterinary Journal*, 3, 57-58.
- Zhang Nianzu, Hu Yuling, Li Zhihua, Li Gen, Zhang Khaili and Zhou Fuzhong. 1989a. The preparation and specific test of soluble antigen for AGID test of bluetongue disease. *Yunnan Animal Husbandry and Veterinary Journal*, 4, 13-16.
- Zhang Nianzu, Zhang Khaili, Li Zhihua, Hu Yuling, Li Gen, Zhao Kun, Zhou Fuzhong and Shanyu Naishun. 1989b. Application of agar gel immunodiffusion test for the diagnosis of bluetongue in animals. *Yunnan Animal Husbandry and Veterinary Medicine*, 4, 17-19.
- Zhang Nianzu, Zhang Khaili, Li Zhihua, Shanyu Naishun, Hu Yuling, Li Gen, Zhao Kun, Zhou Fuzhong and Xu Wenzhen. 1989c. Investigation and study of bluetongue disease of sheep in Yunnan, China. *Yunnan Animal Husbandry and Veterinary Journal*, 4, 3-12.

# Detection of Bluetongue in China by Polymerase Chain Reaction (PCR)

Peng Kegao\*, A.R. Gould<sup>†</sup>, Li Huachun\*, Ben Jin\*, J.A. Kattenbelt<sup>†</sup>,  
Li Xinrong\* and Zhang Fuqiang\*

## Abstract

The polymerase chain reaction (PCR) was used to confirm the presence of bluetongue virus (BLU) in tissue culture cells, chicken embryo and clinical blood samples. BLU VP3 specific oligonucleotides were used in PCR-based diagnostic tests to exclude the possibility of other orbiviruses, which corroborated previous field and diagnostic assessments. The VP3 oligonucleotides, which successfully amplified genes sequences from the BLU isolates from China, have been successfully tested previously on viral isolates from many temperate zone regions around the world. A set of oligonucleotides with sequences derived from the Australian BLU1 VP2 sequence was tested for its ability to act as a set of 'generic' VP2 primers to amplify VP2 sequences irrespective of viral serotype. From an analysis of these VP2 PCR reactions, we were able to determine that a minimum of three separate serotypes were present in the isolates tested. PCR analysis of blood samples from Shanxi, performed in 36 hours, demonstrated the speed and efficiency with which a positive diagnosis could be made, and compared very favourably with more traditional diagnostic and tissue culture methods for identifying viruses in sera.

BLUETONGUE virus (BLU) is the type member of the orbivirus genus within the family Reoviridae. BLU possesses a segmented genome of 10 double-stranded (ds) RNA genes which code for seven structural and three non-structural proteins within virus-infected cells. Many attempts have been made to construct gene probes (Purdey et al. 1984; Ghiasi et al. 1985; Squire et al. 1985; Mertens et al. 1987; Pedley et al. 1988; Gould 1989; Wilson 1990) or polymerase chain reaction (PCR) tests (Wade-Evans et al. 1990; Dangler et al. 1990; Wilson et al. 1990; McColl and Gould 1991, 1994) to identify and discriminate this serogroup from other orbiviruses. However, the variation of the gene segments for BLU isolates from different regions of the world (Gould and Pritchard 1990, 1991; Pritchard and Gould 1995) have made this approach untenable in certain situations. VP3,

VP7 and NS1 gene probes vary by as much as 20% at the gene level within the same serogroup, and by 30% when compared to other closely related orbiviruses (Gould 1987, 1988; Gould et al. 1988; Gould and Pritchard 1991). Using a gene probe to discriminate between closely related orbiviruses and bluetongue viruses from different geographic regions, by varying the hybridisation conditions, has thus proven unreliable (Gould 1987). While polymerase chain reaction (PCR) tests have been used to identify BLU isolates in clinical samples and from different viral isolates, in general these oligonucleotides have been designed to amplify gene sequences from the same geographic region (Wade-Evans et al. 1990; Dangler et al. 1990). Only one set of oligonucleotides has been rigorously tested on BLU isolates from different geographic regions (McColl and Gould 1991; Gould and Pritchard 1991). These oligonucleotides have been used successfully to amplify BLU isolates from Australia, Indonesia, Malaysia, India, South Africa, the Caribbean and North America (Pritchard and Gould 1995). In this way, three major and several minor geographically distinct types of viruses (topotypes) have been identified. The speed and accuracy

\* Yunnan Tropical and Subtropical Animal Virus Disease Laboratory, Jindian, Kunming 650224, People's Republic of China.

<sup>†</sup> CSIRO, Australian Animal Health Laboratory, PO Bag 24 Geelong, Victoria 3220, Australia.

of the BLU PCR has been demonstrated adequately by several laboratories. However, to be a truly universal system for the rapid identification of BLU viruses, these diagnostic oligonucleotides must be capable of amplifying a gene segment irrespective of the toptype of the BLU isolate. To this end we have attempted to test the response of the BLU PCR to virus present in tissue culture cells, chicken embryos and clinical blood samples of BLU isolates in China.

## Materials and Methods

### Viral isolates

In this study the viral strains came from isolates held at the Yunnan Tropical and Subtropical Animal Laboratory, Jindian, Kunming. Unless stated otherwise, viruses were isolated from sheep blood by direct inoculation onto BHK cells. BLU strains used in this study were:

- BLU-H originally isolated in Wuhan province (Hubei) in 1987;
- BLU-IM8 and BLU-IM isolated from goats in Inner Mongolia in 1988 and 1990 respectively;
- BLU-Y isolated in Yunnan (Jindian province) in 1979;
- BLU-XJ isolated at Xinjiang in 1989; and
- BLU-SX, sheep blood from a suspected BLU outbreak at Shangxi province in October 1993.

BLU-Y was inoculated into a chicken embryo: after 72 hours, the brain, heart, liver and kidney were dissected, homogenised using a mortar and pestle, and the nucleic acids extracted as described by McColl et al. (1994).

### DNA oligonucleotides and PCR conditions

DNA deoxyoligonucleotides were synthesised on an Applied Biosystems DNA synthesiser using phosphoramidite chemistry. Oligonucleotides were purified either by electrophoresis through 14% polyacrylamide gels followed by elution and C<sub>18</sub> Sep-Pac column elution, or by precipitation using *N*-butanol (Sawadogo and Van Dyke 1990). The oligonucleotides for both VP3- and VP2-based PCR reactions (McColl and Gould 1994; Pritchard and Gould 1995) were used to amplify BLU-specific sequences from nucleic acids extracted from tissue culture cells, chicken embryos and clinical blood samples. PCR conditions were as described by McColl and Gould (1994) for both primary and nested (secondary) amplification cycles. PCR products were visualised in 1% agarose-tris-acetate-EDTA gels after electrophoresis in the presence of ethidium bromide and illumination with ultraviolet light. DNA markers were prepared by the digestion of DNA with the restriction endonuclease *Ava*I following the manufacturer's instructions.

## Results

Nucleic acids extracted from BLU-infected BHK cells were subjected to amplification using PCR and BLU VP3-specific oligonucleotides. BHK cells uninfected with virus were used as controls. Of the strains tested, seven were positive in BLU-specific reactions, while two were consistently negative (Table 1). The latter were an unknown virus isolated from insects (a suspected BLU designated WT-1) and BHK control cells. Of the isolates positively identified as BLU by VP3-specific PCR tests, four were also found to be positive in PCR reactions using the 'generic' VP2-specific primers, again confirming the BLU identity of these isolates. Two of the BLU isolates (BLU-H and BLU-S) were consistently negative in both primary and nested PCR tests. BLU-Y, which gave a strong PCR product using the primary VP2 primers, produced a slightly weaker positive signal after nested PCR. The ability of the PCR tests to detect low levels of BLU circulating in chicken embryo tissues was also tested (Table 1). Embryo brain tissue was a rich source of virus, while the other tested tissues had lower levels of virus. A clinical sample was also included to demonstrate the applicability of the PCR test to detect virus circulating in sheep's blood. Using a nested PCR, BLU-S was identified as being present in the clinical sample, although the amount of virus in this sample was insufficient to be detected in a primary PCR reaction. This occurrence has been observed routinely in clinical blood samples tested for the presence of BLU (McColl and Gould 1994).

## Discussion

This study has indicated the usefulness of PCR as a diagnostic technique. The results reported here demonstrate that PCR can discriminate between BLU and other viruses, and that the level of non-specific reactions from tissue culture cells and clinical samples is negligible. We found that PCR tests were able rapidly to detect the presence of virus in clinical blood samples from infected sheep, without previous amplification using tissue culture or egg inoculation. This greatly reduces the time needed for a positive diagnosis from a matter of weeks to 36 hours. The sensitivity and specificity of the PCR test has been investigated thoroughly (McColl and Gould 1991, 1994; McColl et al. 1994). The ability to detect virus present in the tissues of a chicken embryo demonstrate the usefulness of the technique to detect the presence of high titre virus in tissues before attempted virus propagation through tissue culture. Again this should decrease the time taken for virus identification and characterisation.

Sequencing PCR products can generate valuable information about the phylogenetic relationships and serotypes of these viruses (Gould and Pritchard 1990, 1991). The differential reaction of the Chinese BLU isolates with the VP2-specific serotypes in primary and nested PCR tests indicated that there were at least three different serotypes in China. Serotype determination will have to await either sequencing studies or serum neutralisation tests. PCR-based tests have also shown that the primers used in these studies have universal application in the detection and identification of viruses of the bluetongue serogroup, irrespective of their geographic origin. To date these are the only 'serogrouping' oligonucleotides thoroughly tested on BLU isolates from around the world using clinical, tissue culture, blood or fixed tissues in PCR.

**Table 1.** Reactions of Chinese viral isolates with serogroup and serotype-specific BLU primers.

BLU isolate <sup>a</sup>	Primers	
	VP3	VP2
H	+++ (+++)	—
S	+++ (+++)	—
IM	+++ (+++)	+++ (+++)
IM-8	+++ (+++)	+++ (+++)
Y	+++ (+++)	+++ (++)
SX	(+++)	nt
XJ	+++ (+++)	+++
WT-I	—	—
BHK control nucleic acid	—	—
Brain <sup>b</sup>	+++	nt
Kidney <sup>b</sup>	++	nt
Heart <sup>b</sup>	+	nt
Liver <sup>b</sup>	+	nt

<sup>a</sup> see text for descriptions of isolates

<sup>b</sup> nucleic acid isolated from chick embryo tissue

— denotes positive reaction after PCR

++ denotes strong positive reaction after PCR

+++ denotes very strong positive reaction after PCR

— denotes no observable amplification product after PCR

( ) denotes the strength of the amplification signal observed after nested PCR

nt not tested

### Acknowledgments

A.R. Gould and J.A. Kattenbelt are indebted to ACIAR for special funding for this investigation.

### References

- Dangler, C.A., de Mattos, C.A., de Mattos, C.C. and Osburn, B.I. 1990. Identifying bluetongue virus ribonucleic acid sequences by the polymerase chain reaction. *Journal of Virological Methods*, 28, 280–292.
- Ghiasi, H., Purdy, M.A. and Roy, P. 1985. The complete sequence of bluetongue virus serotype 10 segment 3 and its predicted VP3 polypeptide compared with those of BLU serotype 17. *Virus Research*, 3, 181–190.
- Gould, A.R. 1987. The complete nucleotide sequence of bluetongue virus serotype 1 RNA3 and a comparison with other geographic serotypes from Australian South African and the United States of America and with other orbivirus isolates. *Virus Research*, 7, 169–183.
- 1988. Conserved and non-conserved regions of the outer coat protein VP2 of the Australian bluetongue serotype 1 virus revealed by sequence comparison to the VP2 of North American BLU serotype 10. *Virus Research*, 9, 145–158.
- 1989. The use of recombinant DNA probes to group and type orbiviruses. A comparison of Australian and South African isolates. *Archives of Virology*, 9, 205–220.
- Gould, A.R. and Pritchard, L.I. 1990. Relationships amongst bluetongue viruses revealed by comparisons of capsids and outer coat protein nucleotide sequences. *Virus Research*, 17, 31–52.
- 1991. Phylogenetic analyses of the complete nucleotide sequence of the capsid protein (VP3) of Australian epizootic haemorrhagic disease of deer virus (serotype 2) and cognate genes from other orbiviruses. *Virus Research*, 21, 1–18.
- Gould, A.R., Pritchard, L.I. and Tavaría, M.D. 1988. Nucleotide and deduced amino acid sequences of the non-structural protein NS1 of Australian and South African bluetongue virus serotype 1. *Virus Research*, 11, 97–107.
- McColl, K.A. and Gould, A.R. 1991. Detection and characterisation of bluetongue virus using the polymerase chain reaction. *Virus Research*, 21, 19–34.
- 1994. Bluetongue virus infection in sheep: haematological changes and detection by polymerase chain reaction. *Australian Veterinary Journal*, 71, 97–101.
- McColl, K.A., Gould, A.R., Pritchard, L.I., Melville, L. and Bellis, G. 1994. Phylogenetic characterisation of bluetongue viruses from naturally infected insects, cattle and sheep in Australia. *Australian Veterinary Journal*, 71, 102–105.
- Mertens, P.P.C., Pedley, S., Cowley, J. and Burroughs, J.N. 1987. A comparison of six different bluetongue virus isolates by cross-hybridization of the dsRNA genome segments. *Virology*, 161, 438–447.
- Pedley, S., Mohamed, M.E.H. and Mertens, P.P.C. 1988. Analysis of genome segments from six different isolates of bluetongue virus using RNA-RNA hybridization: a generalized coding assignment for bluetongue viruses. *Virus Research*, 10, 381–390.
- Pritchard, L.I. and Gould, A.R. 1995. Complete nucleotide sequence of the RNA segment 3 of bluetongue virus serotype 2 (Ona-A). Phylogenetic analyses reveal the probable origin and relationship with other orbiviruses. *Virus Research*, 35, 247–261.
- Purdy, M.A., Petre, J. and Roy, P. 1984. Cloning of the bluetongue virus L3 gene. *Journal of Virology*, 51, 754–759.

- Sawadogo, M. and Van Dyke, M.K. 1990. A rapid method for the purification of deprotected oligonucleotides. *Nucleic Acids Research*, 19, 674.
- Squire, K.R.E., Chuang, R.Y., Chuang, L.F. and Doi, R.H. 1985. Detecting bluetongue virus RNA in cell culture by dot hybridization with a cloned genetic probe. *Journal of Virological Methods*, 10, 59-68.
- Wade-Evans, A.M., Mertens, P.P.C. and Bostock, C.J. 1990. Development of the polymerase chain reaction for the detection of bluetongue virus in tissue samples. *Journal of Virological Methods*, 30, 15-24.
- Wilson, W.C. 1990. Development and optimization of a hybridization assay for epizootic hemorrhagic disease viruses. *Journal of Virological Methods*, 30, 2173.
- Wilson W.C., Fukosho A. and Roy, P. 1990. Diagnostic complementary DNA probes for genome segments 2 and 3 of epizootic hemorrhagic disease virus serotype 1. *American Journal of Veterinary Research*, 516, 855-860.

# Studies of a Non-radioactive Gene Probe for Bluetongue Viruses

Peng Kegao, Li Zhihua and Li Gen\*

## *Abstract*

A non-radioactive gene probe was used for bluetongue virus (BLU) analysis. RNA was extracted and purified, at the peak of the cytopathic effects (CPE), from BHK21 cell cultures inoculated with Yunnan local isolate. This RNA was identified as bluetongue (OD260/OD280 was  $> 1.6$ ). It was then labelled with non-radioactive labels including biotin and photobiotin. The Dot-Blot technique was used to test the probe both with biotin-AKP and HRP. The non-radioactive labelled RNA probe was obviously hybridised with known bluetongue viruses and not with epizootic hemorrhagic disease (EHD) virus, cell RNA or the negative control. The background of biotin-AKP was lower than that of biotin-HRP. The technique using a non-radioactive gene probe to study bluetongue appears acceptable, as it can distinguish bluetongue group specificity, although not individual serotypes. In comparison with the radioactive gene probe, the non-radioactive labelled BLU was easily, safely and effectively applied for analysis of bluetongue viruses.

---

\* Yunnan Tropical and Subtropical Animal Virus Diseases  
Laboratory, Jindian 650224, Kunming, People's Republic of China.

# **Analysis of Local Isolates of Bluetongue Viruses in China by SDS-PAGE**

**Hu Yuling and Peng Kegao\***

## *Abstract*

The RNA of four bluetongue isolates from Yunnan, Hubei, Sichuan and Inner Mongolia (China), and of two standard serotypes from USA (BLU-A10 and BLU-A17), were analysed by SDS-polyacrylamide gel electrophoresis (SDS-PAGE). All six samples were prepared from BHK21 cell cultures showing cytopathic effects (CPE) after inoculation with the isolates and serotypes. Ten fragments were seen on the gels of all samples, which could be divided into four groups: 1-3, 4-6, 7-9 and 10. The type of fragments of RNA was 3, 3, 3, 1. There were no significant differences between the types of fragments from local isolates and those from standard serotypes. Thus SDS-PAGE used in this way could be a technique for bluetongue group identification but would not be recommended as the method for identification of a specific serotype.

---

\* Yunnan Tropical and Subtropical Animal Virus Diseases Laboratory, Jindian 650224, Kunming, People's Republic of China.



# A Study of the ELISA Test for the Detection of Epizootic Hemorrhagic Disease (EHD) Virus Infection

Li Xiaocheng\*, Yang Chengyu\*, Zhang Yianxia\*, Cheng Xiengfu\*,  
Pu Shuying\*, Cheng Zhongguo†, Meng Guangxiao† and Li Baojia†

## *Abstract*

New Jersey-EHD1, Canadian Alberta-EHD2 and Ibaraki viruses were grown in BHK21 cells and purified as antigens for enzyme linked immunosorbent assay (ELISA). Antigen prepared with Ibaraki virus gave quite good group-specificity. The whole cell cultures were centrifuged and the supernatant, with 0.5% NP<sub>40</sub> added and treated with 250 units/mL heparin, subjected to ultracentrifugation. The purified viral particles as antigen gave the best results. Based on the agar gel immunodiffusion (AGID) results from 1420 cattle and sheep sera, the upper limit of the 99% negative confidence was 2.5 and the lower limit of the 99% positive confidence was 3.0, estimated by statistical treatment of the ratio of sera test value/standard negative sera test value with ELISA. The zone between 2.5 and 3.0 was regarded as suspicious. All 2484 cattle and sheep sera submitted for examination, tested by both AGID and ELISA, had a positive rate of 19.04% with AGID and 26.037% with ELISA. Samples that tested positive by ELISA included 99.58% of the samples that tested positive by AGID. When sera from a further 4296 cattle and sheep were tested by ELISA, the positive rate was 22.94%.

---

\* Animal Quarantine Institute, Ministry of Agriculture, Qingdao 266032, People's Republic of China.

† Animal and Plant Quarantine Bureau, Qingdao 266011, People's Republic of China.

# **A Rapid ELISA Procedure for Detection of Antibody to Bluetongue Viruses**

**Yang Chengyu, Cheng Xiengfu, Ma Hongchao, Fan Gencheng,  
Li Xiaocheng and Pu Shuying\***

## *Abstract*

By optimising the reaction conditions, a rapid enzyme linked immunosorbent assay (ELISA) procedure was developed to detect bluetongue antibodies. After the coating process the procedure was completed in 45 minutes, two thirds of the previous required time, with the same sensitivity. Using this process to test 70 sera resulted in 12.9% more positives being detected than with agar gel immunodiffusion (AGID).

---

\* Animal Quarantine Institute, Ministry of Agriculture, Qingdao, People's Republic of China.

# **A Serological Identification of Shandong Strain of Bluetongue Virus**

**Yang Chengyu, Pu Shuying, Ma Hongchao, Cheng Xiengfu,  
Li Xiaocheng, Fan Gencheng and Zhang Yianxia\***

## *Abstract*

An isolate (L001) of bluetongue virus was typed using the plaque inhibition test with both standard type-specific antisera and those prepared by this laboratory. A suspension procedure of plaque inhibition was developed to type the isolate. The results showed the isolate was identical to the standard strain of BLU16. In addition, the RNA-map of L001 in polyacrylamide gel electrophoresis (PAGE, 10%) was the same as that of BLU16, confirming that L001 was BLU16.

---

\* Animal Quarantine Institute, Ministry of Agriculture,  
Qingdao 266032, People's Republic of China.

# Serological Cross-reactions between Bluetongue and Epizootic Hemorrhagic Disease (EHD) Virus Groups in Agar Gel Immunodiffusion (AGID) Tests

Li Xiaocheng, Yang Chengyu, Chang Yanxia, Pu Shuying and Cheng Xiengfu\*

## *Abstract*

Antisera and antigens were prepared with bluetongue (serotypes BLU1 to BLU22), epizootic hemorrhagic disease (EHD1, 2) and Ibaraki viruses. Agar gel immunodiffusion (AGID) tests gave the following results:

- no reaction occurred between EHD2 antigen and EHD1 antiserum
- precipitin lines developed between antigens of EHD1 or Ibaraki virus and antiserum to EHD2
- antigens to BLU10, 17 and 20 reacted with antisera to EHD1, 2 and Ibaraki viruses
- EHD1 antigen reacted with antisera to BLU4, 9, 10, 12, 14, 15, 17 and 20
- EHD2 antigen reacted with antisera to BLU4, 10, 12, 16, 17, 20 and 21
- no cross-reaction occurred between Ibaraki antigen and antisera to BLU1 to BLU22
- cross-reactions between EHD antigens and antisera to BLU1 to BLU20 were related to repeat inoculations of animals with single BLU serotypes
- EHD1 antigen did not react with antisera to BLU16, 18, 19, 21 and 22 from animals which had received a single dose in their preparation, but did react after second doses
- EHD2 antigen did not react with antisera to BLU14, 15, 18, 19 and 20 from animals which had received a single dose in their preparation, but did react after second doses.

There is thus ample evidence of cross-reactivity between antigens prepared from EHD virus and antisera to bluetongue serotypes.

---

\* Animal Quarantine Institute, Ministry of Agriculture, Qingdao 266032, People's Republic of China.

# **A Comparison of BHK21, Vero and C6/36 Cell Lines in the Preparation of the AGID Antigen of Bluetongue Virus**

**Li Xiaocheng and Zhang Yianxia\***

## *Abstract*

Agar gel immunodiffusion (AGID) is a test for detecting bluetongue virus commonly used in some regions and countries. Years of comparative experiments have shown the C6/36 cell line to be very much superior to BHK21 and Vero cells in the preparation of the AGID antigen of bluetongue virus serotype. Antigen production in C6/36 was 25 times greater than with BHK21 or Vero cells. Antigen titre with BHK21 or Vero was <1:8 while the titre with C6/36 was >1:8, and AGID with BHK21 or Vero antigens could be read in 48 hours. Parallel and block tests showed both antigens had equal specificity. The C6/36 antigen revealed clear and dense precipitating lines with positive sera.

---

\* Animal Quarantine Institute, Ministry of Agriculture, Qingdao 266032, People's Republic of China.

# Enhancement of Growth of Bluetongue Viruses in Cell Cultures through Trypsin Treatment

Li Gen, Peng Kegao, Zhang Fuqiang and Li Xinrong\*

## *Abstract*

Bluetongue viruses were treated with trypsin (final concentration 5µg/mL) for 30 minutes at 37°C, then inoculated onto BHK21 or Vero tissue culture monolayers. The maintenance medium contained trypsin at 1 µg/mL. This method promoted viral propagation, enhancing the titre from  $10^{4.62}$  to  $10^7$  in BHK21 cells and from  $10^4$  to  $10^6$  in Vero cells. The treated viruses were passaged in cell culture so viability was not affected. Polyacrylamide gel electrophoresis (PAGE) indicated that the virus protein structure had not changed.

---

\* Yunnan Tropical and Subtropical Animal Virus Diseases Laboratory, Jindian 650224, Kunming, People's Republic of China.

# Comparison of the Value of AGID and ELISA Antigen in the ELISA Test for Bluetongue Viruses

Yang Chengyu, Chen Xiengfu, Ma Hongchao, Fan Gencheng,  
Li Xiaocheng and Pu Shuying\*

## *Abstract*

Sera from 125 cattle and sheep in a bluetongue epidemic area, and 3020 survey sera, were tested in parallel using agar gel immunodiffusion (AGID) or enzyme linked immunosorbent assay (ELISA) tests with ELISA antigen. The tests matched for quality and quantity, and the results showed a high correlation; 0.998 for cattle sera and 0.999 for sheep sera. The similarity of these results lead us to suggest that AGID antigens could be used instead of ELISA antigens.

---

\* Animal Quarantine Institute, Ministry of Agriculture,  
Qingdao 266032, Shandong, People's Republic of China.

# Vaccine and Control



# Introduction

IN this section the spectrum of vaccines is canvassed. Vaccines used in sheep on farms have ranged from empirical applications, without knowing the relevant serotype identity, to the use of inactivated whole virus, or inactivated and attenuated live virus. Non-living bluetongue virus constructs (for example, core-like particles, or CLPs) have been shown to be effective on an experimental basis. With the classification of all available bluetongue strains, the need for empirically developed vaccines has now passed in China. All countries in this region can now have their bluetongue viruses identified to serotype. Information on serotypes known to exist in Southeast Asia and the Pacific countries is increasing rapidly. This means significant problems in having available vaccines for many of the serotypes, a situation that applies regardless of whether manufacture is of safe inactivated vaccines or of the controversial, teratogenic, live attenuated vaccines.

Vaccines made from artificial constructs of bluetongue viruses can be made polyvalent, to a limited extent, and are safe. Papers in this section describing

the value of core-like particles in reducing the severity of bluetongue disease in sheep suggest broad spectrum effectiveness. Certainly, a broad spectrum vaccine would not only limit the economic effects of outbreaks but would also allow preconditioning of susceptible sheep that were to be imported into endemic areas. Knowing the threatening serotype would then become of secondary importance. Further testing of core-like particles as vaccines seems very important in countries of this region.

The situation that has evolved in the United States of America and South Africa may have been partially created by the intense use of live attenuated vaccines, which made available genes for transfer to naturally occurring viruses. The altered genotype may enable the virus to cross the placenta and damage the foetus. Once released into the environment, altered bluetongue live viruses may exchange genetic information by reassortment in cattle, sheep, goats, deer or *Culicoides*. There is still a chance of avoiding this fundamental mistake in Asia and Australia.

# Development of Bluetongue Virus Multicomponent Vaccines Using a Novel Baculovirus System

P. Roy\*

## Abstract

The difficulties associated with obtaining completely safe, live virus vaccines by the traditional procedures of virus passage and selection of attenuated forms, as well as the risks and expenses involved in preparing killed or subunit vaccines from virulent viruses, may now be overcome using recombinant DNA technologies. Genetic engineering offers a variety of ways of preparing viral vaccines using expression vector systems. Using baculovirus multiple gene expression vectors based on *Autographa californica* nuclear polyhedrosis virus (AcNPV) has provided a new strategy for vaccine development. Such vectors are capable of the simultaneous expression of several foreign genes within the host insect cell in which AcNPV replicates. Using this technology, we have developed multicomponent virus-like particles (VLPs) as virus vaccines and used them as vaccine delivery systems for multiple immunogens. The VLP technology is a completely new technical development from a novel baculovirus expression vector system, which has the capability of simultaneously co-expressing up to five proteins in insect cell culture. The transformed cells are stable, and authentic protein product is produced at high levels. This novel technology has been used for the production of pilot-scale quantities of a recombinant bluetongue virus (BLU) multi-subunit vaccine (VLPs immunologically indistinguishable from BLU). Preliminary clinical trials have verified this vaccine's safety and efficacy. Unlike live virus vaccines, VLPs are non-infectious and lack virus (or other) DNA/RNA required for replication. VLPs do not replicate in host cells. However, trials in sheep have shown that VLPs are more immunogenic than subunit vaccines (viral proteins) or than viruses inactivated chemically. In addition, VLPs are effective at eliciting humoral, cell-mediated and mucosal immunities, and are safe to produce and handle. (As the baculovirus vector and host cells used to make VLPs do not come from mammalian sources, they do not contain mammalian derived pathogens.) The expression system described in this paper is a tool which may have a range of applications in industries employing biotechnology to produce vaccines, insecticides, or diagnostic and protein reagents. Diagnostic reagents developed for BLU and African horsesickness virus are discussed as examples.

GENETIC engineering offers a variety of approaches for viral vaccines. An exciting advance in this field is the ability to construct virus-like particles (VLPs) which resemble their natural counterparts but lack genetic information (i.e. are unable to replicate). We have developed VLPs based on bluetongue

virus (BLU), the causative agent of bluetongue disease of sheep.

To date, 24 BLU serotypes (BLU1, BLU2, etc.) have been identified from different parts of the world (Erasmus 1990). In the past, live attenuated orbiviruses have been used as reasonably effective vaccines in those regions where bluetongue virus causes epidemics of disease in livestock. However, as the BLU genome comprises 10 double-stranded (ds) RNA species, there is some concern that using live attenuated viruses in vaccines may maintain the virus in the wild, and facilitate RNA segment reas-

---

\* NERC Institute of Virology & Environmental Microbiology, Oxford, U.K. (address for correspondence); Laboratory of Molecular Biophysics, University of Oxford, U.K.; and University of Alabama at Birmingham, USA.

sortment and the generation of new viral genotypes. This is especially important as not all the attenuated derivatives of the known BLU serotypes appear adequately attenuated.

## The Bluetongue Virus

The architecturally complex, 810 Å diameter bluetongue virus can attach to, and replicate in, a variety of vertebrate cells (Roy, 1996). The virion contains seven structural proteins, four of which are organised into two protein shells. The outer shell contains two major protein species, VP2 (110 kD) and VP5 (58 kD), while the inner shell has two other major species, VP3 (100 kD) and VP7 (38 kD). The icosahedral inner shell encapsidates the virus genome and three other (minor) proteins; VP1 (150 kD), VP4 (76 kD) and VP6 (36 kD). In addition, three or four non-structural proteins are synthesised in virus-infected cells. Of the ten proteins, only VP2 and VP5 vary from serotype to serotype. All five core proteins and the three non-structural proteins are highly conserved (Roy et al. 1990a). Each protein is encoded by a single BLU dsRNA segment (Mertens et al. 1984). To develop rationally-designed BLU vaccines in the past few years, we have been developing an understanding of the structural and functional relationships of BLU genes and gene products, and of the assembly of the gene products for the formation of virions.

## Baculovirus Expression Vectors

Recent advances in gene manipulation have made it possible to express foreign genes in heterologous systems. The productivity and flexibility of insect baculovirus expression vectors, and the ability of the baculovirus genome to incorporate (and express) large amounts of foreign DNA in *Spodoptera frugiperda* insect cells, have permitted this system to be used for the expression not only of a single gene, but also for the simultaneous expression of dual and multiple genes. To accomplish this, several expression vectors have been developed based on the resident promoters of AcNPV, the nuclear polyhedrosis virus of *Autographa californica* (Bishop 1992; Belyaev and Roy 1993; Belyaev et al. 1995).

Using these various expression vectors, we have expressed all 10 BLU genes, either individually or in various combinations, using single, dual, triple and quadruple expression vectors, and have analysed the structure-function of each gene and gene product (Roy 1992). However, only the structural characteristics and functional attributes of those proteins relevant to generation of vaccines are discussed in this paper.

## Assembling BLU Core-like Structures with Baculovirus Expression Systems

### Core-like particles

The flexibility of baculovirus expression vectors and the capacity of the baculovirus genome to accommodate large amounts of foreign DNA has allowed us to exploit the system for the simultaneous expression of multiple BLU genes in a single insect cell. Our initial effort was to assemble the two major core proteins, VP3 and VP7. For this purpose, a dual baculovirus expression vector consisting of duplicated polyhedron promoters (PH) of AcNPV, with downstream transcription terminator sequences, was used to express the coding sequences of the L3 (VP3) and S7 (VP7) genes of BLU (French and Roy 1990). Recombinant baculoviruses synthesising both proteins were isolated and produced core-like particles (CLPs) distributed throughout the infected insect cells. Gradient-purified CLPs were similar in size and appearance to cores prepared from BLU (Fig. 1). Only VP3 and VP7 were identified as the protein components of the expressed particles and the molar ratios of these two proteins were similar to those of VP3 and VP7 derived from infectious BLU. The CLPs appeared to lack nucleic acids when analysed by phenol-chloroform extraction and alcohol precipitation.

### Three-dimensional structures of BLU cores and CLPs

To determine whether CLPs mimic the morphology of BLU-derived core particles, cryoelectron microscopy (cryo-EM) was used to examine unstained, unfixed virus-derived core particles (i.e. avoiding heavy metal stains, fixture and dehydration: Prasad et al. 1992; Hewat et al. 1992a). Using image reconstruction methods, the micrographs of cores at 30 Å resolution revealed that the particles were 690 Å in diameter, exhibited an icosahedral symmetry and contained surface knobs organised with a triangular number of 13 (Prasad et al. 1992). The surface consisted of clusters of VP7 trimers providing 260 prominent knob-like protrusions (780 VP7 molecules) organised into pentameric and hexameric units with channels in between (Fig. 2). A total of 132 channels per particle were identified, involving all three-fold axes. The aqueous channels are approximately 70 Å deep and 80 Å wide at the surface. Some channels penetrate to the inner layer, and are probably the pathways for metabolites to reach the sites of viral mRNA transcription and the export of nascent mRNA molecules out of the cores. The underlying smooth scaffold for the VP7 trimers consists of the second major core protein, VP3, the organisation of which was not fully revealed at 30 Å resolution (Fig. 2). The VP7 and VP3 enclose the inner core, which comprises the three

minor proteins VP1, VP4 and VP6 and the genomic dsRNA. We do not yet know how these are organised with respect to one another or to VP3 and VP7.

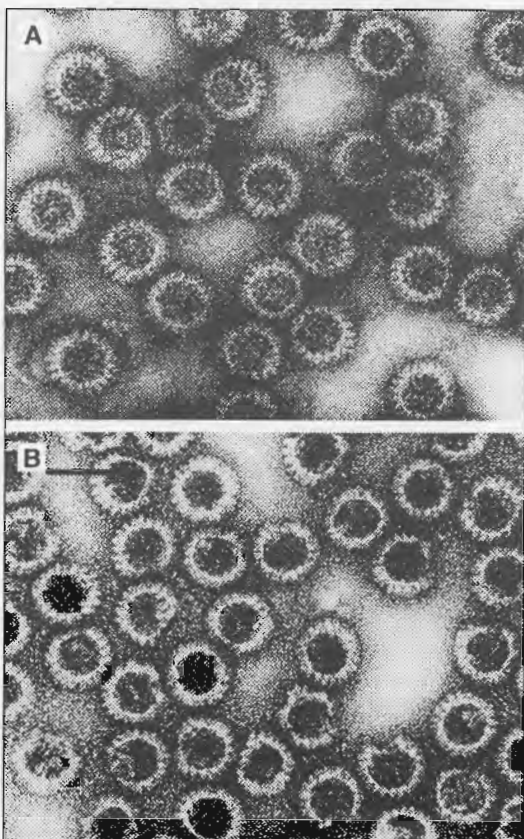

**Figure 1.** Electron micrographs of (A) authentic BLU cores and (B) baculovirus-expressed core-like particles (CLPs).

The images of baculovirus-synthesised CLPs at relatively low resolution (65 Å) revealed a similar icosahedral configuration ( $T=13$  for the surface layer) and an identical diameter (690 Å) to that of BLU cores. Some of the synthetic CLPs lacked the full complement of VP7. In these, the shapes of the VP7 trimers were clearer (Hewat et al. 1992a). The trimers have tripod-like shapes and each consists of an upper (outermost) and lower (innermost) domain. The shapes and structures of VP7 trimers have recently been confirmed by X-ray crystallographic data (Grimes et al. 1995). It appears that the VP3 molecules are roughly disc-shaped and that dimers of VP3 form the building blocks for the icosahedral structure. There are a total of 120 VP3 molecules per virion, organised in a triangulation number of  $T=1$ . VP3 subcores have been purified

from CLPs. The cryo-EM data obtained for purified subcores appear similar to those deduced from VP3 in CLPs (Hewat et al. 1992a).

#### **Incorporation of the three minor proteins within CLPs**

To determine whether the three minor proteins can be assembled into CLPs, VP1 and/or VP4 and/or VP6 have been co-expressed using baculovirus vectors together with VP3 and VP7. VP1, the putative viral polymerase, was readily incorporated within CLPs. When the VP7 trimers were removed, the derived subcores consisted only of VP3 and VP1, demonstrating that VP1 interacts with VP3 (Loudon and Roy 1991). Similar results were obtained with VP4 and VP6, and for combinations of all three minor proteins (Le Blois et al. 1991). However, unlike VP1 or VP4, VP6 was only poorly incorporated into CLPs. Since VP6 is a highly basic protein and readily associates with RNA (single- or double-stranded), VP6 may chaperone the incorporation of RNA into particles (or vice versa) and may only be poorly incorporated in the absence of RNA (Roy et al. 1990b; Hayama and Li 1994).

Various assay systems have been developed using purified CLPs and single-stranded RNA species synthesised *in vitro* to determine whether CLPs without the minor protein components retain the ability to interact with viral RNA species. The data indicate that the RNA-binding affinity of CLPs involves VP3 but probably not VP7 (Loudon and Roy 1992). How RNA interacts with VP3 is unknown.

#### **Assembly of bluetongue virus-like particles (VLPs) using baculovirus vectors**

Baculovirus multigene vectors have been developed to co-synthesise up to five BLU proteins in the same cell (Belyaev and Roy 1993; Belyaev et al. 1995). In addition to the PH promoter, copies of the p10 promoter of AcNPV have been utilised to facilitate the high level co-expression of several proteins in each infected cell. For optimum synthesis of VLPs, a quadruple gene expression vector has been used to synthesise BLU VP2, VP3, VP5 and VP7 proteins. The expressed proteins assembled into virtually homogeneous double-capsid particles (Fig. 3). Co-infections with single or dual gene expression vectors gave VLPs that contained different amounts of the outer capsid proteins, depending on the experiment (French et al. 1990). The formation of complete VLPs in the absence of the non-structural proteins implies that the latter are not necessary for the assembly of double-capsid particles (or CLPs). VLPs express high levels of hemagglutination activity, similar to that of BLU virions. Antibodies raised to the expressed particles gave high titres of neutralising activity against the homologous BLU serotype (French et al. 1990).

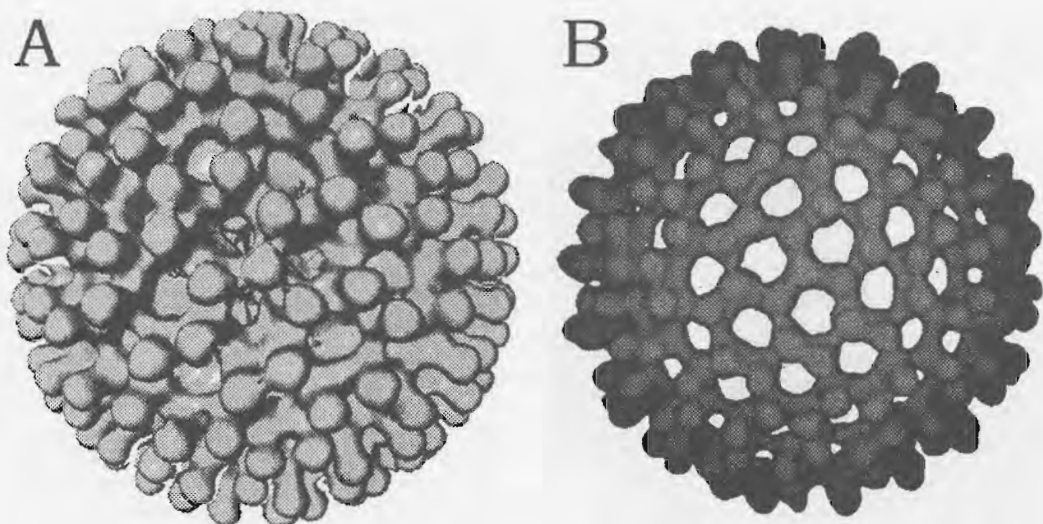

**Figure 2.** Surface representation of the cryoelectron micrographs of the BLU core viewed along the icosahedral three-fold axis, (A) showing the knob-like protrusions of VP7 trimers in the outer layer and (B) the density in the outer layer showing the large holes or channels at all the five- and six-coordinated positions formed by the arrangement of the VP7 trimers.

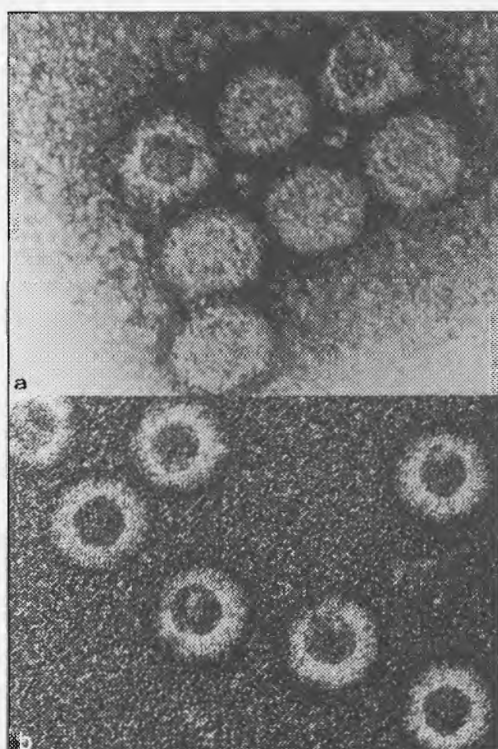

**Figure 3.** Electron micrographs of (A) BLU virions, and (B) baculovirus-expressed double-capsid virus-like particles.

### The three dimensional structures of BLU virions and VLPs

The three dimensional structure of BLU has been determined using image analysis of cryo-electron micrographs of virion particles (Hewat et al. 1992b). The reconstruction revealed a morphology contrasting sharply with that deduced by conventional negative-staining methods. The outer capsid exhibits an icosahedral configuration (860 Å in diameter) and a well-ordered morphology (Fig. 4). The two proteins of the outer capsid have distinctive shapes; one globular and almost spherical, the other sail-shaped. The 120 globular proteins sit neatly on each of the six-membered rings of the VP7 trimers of the core. The sail-shaped spikes are situated above 180 of the 260 VP7 trimers and form 60 triskelion-type motifs which cover all but 20 of the VP7 trimers. These spikes are probably the VP2 hemagglutinating and neutralisation antigens. The two proteins appear to form a continuous layer around the core, except for holes on the five-fold axis. Three dimensional reconstruction of VLPs at 55 Å resolution is comparable to that of authentic virions with diameters of 860 Å, and exhibiting essentially the same basic features and full complement of the four proteins (Fig. 4; Hewat et al. 1994).

### Assembly of Heterologous VLPs Using Different BLU Serotypes

Twenty-four BLU serotypes are recognised. The outer capsid proteins (VP2 and VP5) exhibit the least

conservation among BLU serotypes, in contrast to all the other virus-coded proteins (Roy et al. 1990a). VP2, the main serotype-specific antigen, is the most variable: VP2 sequence identity comparisons between BLU1, 2, 10, 11, 13 and 17 range from 39–73%. Antisera raised to the baculovirus-expressed VP2 of particular BLU serotypes neutralise the homologous virus and, depending on the antigen, to some extent cross-neutralise certain other BLU serotypes (Inumaru and Roy 1987; Urakawa et al. 1994). These data indicate that some BLU serotypes are more closely related than others. In contrast to VP2, the primary sequences of the VP5 proteins of some BLU serotypes are more similar, sharing up to 94% identical amino acids (Hirasawa and Roy 1990; Oldfield et al. 1991; Yang and Li 1992).

The structural compatibilities of various VP2 and VP5 species in VLP formation have been investigated. Heterologous VLPs have been sought by co-infection of insect cells with appropriate recombinant baculoviruses (Loudon et al. 1991). Assembled particles were purified and analysed by electron microscopy and SDS-PAGE to confirm their authenticity. The presence of VP2 and VP5 on VLPs was demonstrated by hemagglutination and Western immunoblotting respectively. Despite the high level of sequence variation amongst the different serotypes, the VP2 and VP5 proteins of six different BLU serotypes formed VLPs with the VP3 and VP7 of another

source (Loudon et al. 1991). Some combinations of VP2 and VP5, such as the VP2 of BLU11 or BLU17 and the VP5 of BLU10, resulted in the assembly of particles, while other combinations, such as the VP2 of BLU2 and the VP5 of BLU10, did not (Table 1). The data indicate that VP2 may require the VP5 of the same or a closely related serotype (e.g. BLU10 or BLU17) but may not form VLPs efficiently with the VP5 proteins of more distant serotypes.

### VLPs as Vaccines

Since recombinant baculovirus-derived VLPs elicited strong neutralising antibodies in guinea pigs, it can be anticipated that, in sheep, VLPs should elicit protective responses against bluetongue viral infection. Several experiments were performed to examine the protective efficacy of VLPs in sheep. Each experiment used groups of BLU-free, BLU-susceptible, one-year-old Merino sheep kept in an insect-proof isolation stable. In the first experiment (Table 2), one group of eight sheep (two sheep for each concentration of protein) was immunised subcutaneously with 2 mL unpurified VP2, or VP2 and VP5 proteins, or VLPs in saline, containing known amounts of protein and suspended in 50% Montanide Incomplete Seppic Adjuvant (ISA-50, Seppic, Paris). As a control, one group of sheep received only saline.

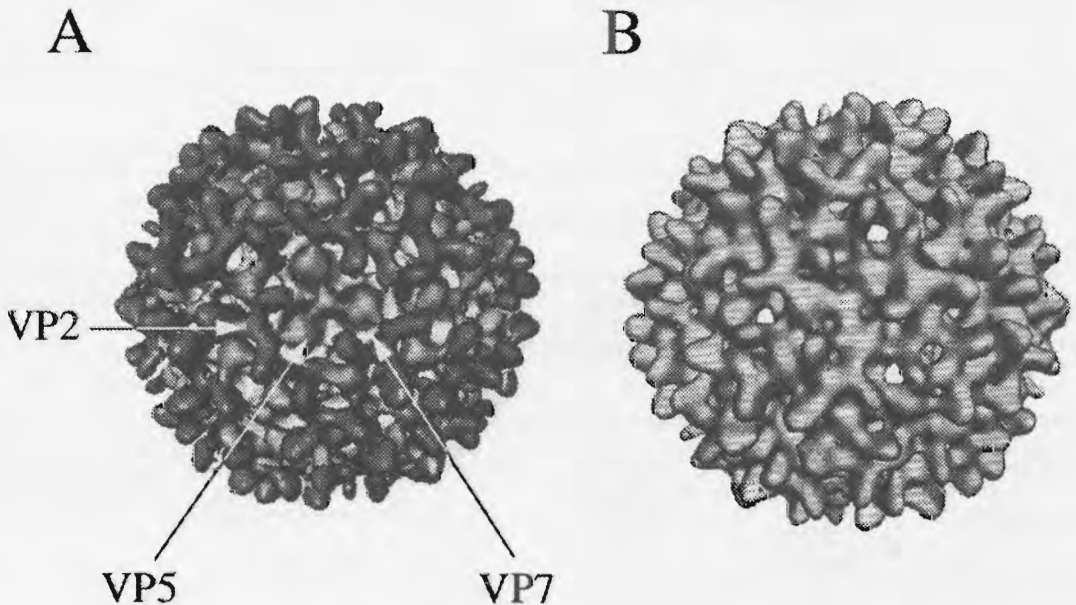

**Figure 4.** Surface representation of a cryoelectron micrograph of (A) an icosahedral virus particle and (B) VLP, viewed along a two-fold axis, showing the topography of the two outercapsid proteins, one globular-shaped (VP5) and the other sail-shaped (VP2). VP7 trimers, underneath, are indicated.



Each immunised animal was boosted with the same amounts of protein on day 21 post-immunisation. From day 21 to the day of challenge, serum from each animal was collected at intervals (Table 2) for virus neutralisation tests. Antibody titres were expressed as the reciprocal of the serum dilution estimated to cause a 50% reduction in plaques. As summarised in Table 1, sheep receiving VLPs developed demonstrable neutralising antibodies, albeit to different levels (Roy et al. 1992, 1994a). The levels of neutralising antibodies depended on the amount of VLPs administered. Significant levels of neutralising antibodies were elicited with all concentrations of VLPs and persisted throughout the study. The control sheep inoculated with saline remained seronegative. All sheep were challenged by subcutaneous inoculation of 1 mL of infective sheep blood containing virulent BLU10 (SA strain) either at day 75 or 117 (Table 2). The animals' clinical reaction indices (CRI) and viraemia were monitored from days 3 to 14 post-challenge (Huismans et al. 1987). Antibody titres of serum collected up to 21 days were also monitored. The challenged sheep developed neither clinical signs nor viraemias, indicating suppressed replication of bluetongue virus. The post-challenge blood samples of the sheep that received only saline were viraemic; these sheep developed high neutralising antibody

titres indicative of a primary infection. To summarise this experiment, protective immunity to bluetongue disease was obtained by vaccinating sheep with doses of 10 µg or more of BLU VLPs as well as with high doses of outer capsid protein VP2 or VP2 and VP5.

To analyse further the protective effects and duration of VLP vaccination, a similar protocol was employed in a second experiment for VLPs (10 µg or 50 µg per sheep) representing BLU10 and BLU17 (Roy et al. 1994a). The neutralising antibody titres of the vaccinated sheep were determined at weekly intervals and during a 60-week period after the booster. Both types of VLP elicited antibodies (to various levels) that neutralised the homologous virus. In almost all cases these neutralising titres remained high throughout the 60-week period. The neutralising antibody titres for the animals receiving 50 µg doses of VLPs were not significantly higher than those in animals receiving 10 µg doses (Table 2). Sheep vaccinated with a mixture of the two types of VLPs developed antibodies that neutralised both types of virus as well as some related heterologous viruses (e.g. BLU4) when tested by plaque reduction assays. As expected, the control sheep inoculated with saline remained seronegative.

All sheep were challenged 14 months after the booster vaccination by subcutaneous injection of vir-

**Table 1.** Formation of VLPs across different bluetongue serotypes.

VP5 origin	VP2 origin					
	BLU1	BLU2	BLU10	BLU11	BLU13	BLU17
BLU2	+	+	-	-	-	-
BLU10	-	-	+	+	-	+
BLU13	nd	nd	-	-	+	-

Notes:

+ and - indicate presence and absence respectively of double-shelled virus-like particles.

nd = experiment not yet done.

*S. frugiperda* cells were infected with combinations of the following recombinant baculoviruses: a dual recombinant expressing VP3 and VP7; a single recombinant expressing VP2 of serotypes 1, 2, 10, 13 or 17; and an additional single recombinant expressing the VP5 of serotypes 2, 10, or 13. The cells were lysed three days post-infection and the resultant particles isolated on discontinuous sucrose gradients. Purified particles were examined under the electron microscope.

**Table 2.** Protective efficacy in sheep of BLU10 outer capsid proteins and VLPs against bluetongue.

Inoculum	No. of sheep per experiment	Neutralising antibodies	Time of challenge	Clinical Reaction Index (CRI)	Viraemia (days post challenge)
VP2 (100 µg)	4-8/group	4-256	75 days	0	0
VP2 (50 µg) plus VP5 (20 µg)	4-8/group	4-256	75 days	0	0
VLPs (10 or 50 µg)	4-8/group	4-256	4 or 14 months	0	0
Saline control	4/group	0	75 days to 14 months	3.6-9.7	D4-14

ulent virus. Animals challenged with homologous viruses (BLU10, BLU17) were completely protected and showed no clinical reactions: this included animals receiving 10 µg VLP doses (Table 3). No viraemias were detected in these animals after challenge. Some animals with 50 µg VLP doses were also protected to a low level when challenged with heterologous virus. In comparison, control animals developed viraemias with high or moderate signs of disease (BLU10 gave CRI of 7.1–8.0; BLU17 gave CRI of 1.6–2.7). Summarising this experiment, the data showed that vaccination with VLPs provided long-lasting protection against homologous BLU challenge. There was some preliminary evidence of cross-protection, depending on the challenge virus and the amounts of antigen used for vaccination (Roy et al. 1994a).

**Table 3.** Protection of sheep by BLU VLPs against heterologous BLU challenge.

Immunised with BLU10, or BLU17, or BLU10 + BLU17 VLPs
(10 or 50 µg/sheep), 4–8 sheep per group
Pre-challenge antibodies: 4–256
Post-challenge (14 months) with BLU4, 10, or BLU17
Clinical reactions — none (BLU4, 10, 17)
Viraemias — none (BLU4, 10, 17)

### Protection Afforded by Cores

We investigated whether CLPs containing the two conserved proteins VP3 and VP7 would provide any homologous and heterologous protection against BLU by a cell mediated mechanism. For the initial studies, we used two groups of five sheep each. One group was inoculated with 50 µg BLU10 CLP in ISA50. The second group was boosted on day 21 and challenged with BLU10 two weeks later.

All post-challenge sheep developed viraemias and neutralising antibodies (Table 4; Roy et al. 1994b). However, with the exception of fever, the vaccinated sheep developed only slight clinical reactions while controls showed characteristic mouth and feet lesions as well as fever. The vaccinated sheep had an average CRI of 3.5 compared to an average of 9.0 for the control sheep. Thus CLP vaccination provided partial protection against BLU challenge. Further experiments are planned to study this aspect further.

### Conclusion

Our results have clearly demonstrated that VLPs are highly immunogenic even at low doses. The sheep given 10 µg doses of VLPs actually received 1–2 µg

of VP2 (10–20% of the VLP mass). This compares well with the much higher amounts required for success in protection studies with VP2 alone, or with VP2 and VP5 mixtures (Roy et al. 1990c). There are several possible explanations. First, the conformational presentations of the relevant epitopes on VP2 probably mimic those on the authentic virus. Second, both VP2 and VP5 are present. Third, the VP3 and VP7 may provide a necessary scaffold for VP2 and VP5 antigen presentation. Fourth, any of the four BLU proteins may have a direct role in eliciting cell-mediated immunity induced by the BLU VLPs. These results suggest that this technology has much to offer for development of vaccines for both veterinary and human diseases. Moreover, there is every reason to believe that it should be possible to make vaccine chimeras representing different BLU serotypes, for example involving the expression of several BLU VP2 genes.

**Table 4.** Protective efficacy in sheep of BLU core-like particles (CLPs) against bluetongue.

Inoculum	Sheep no.	Neutralising antibody	Clinical Reaction Index (CRI)
CLPs	1	320	1.5
	2	160	5.6
	3	320	3.8
	4	160	2.7
	5	160	4.0
	6	320	11.4
	7	320	9.5
Saline control	8	320	12.3
	9	320	6.8
	10	160	5.1

**Note:**

Immunised and control sheep developed viraemias at high neutralising antibody titres. However, clinical signs of bluetongue were less in the vaccinated animals (CRI 1.5–5.6, average 3.5) compared to the controls (CRI 5.1–12.3, average 9.0). Only controls showed characteristic mouth and feet lesions.

Currently, we are also developing BLU CLPs and VLPs to deliver multiple peptide components representing other viral epitopes, to elicit protective immunity agents for different viral diseases. As BLU CLPs and VLPs are large multiprotein structures, they can incorporate alternative protein forms of the structural proteins (e.g. chimeric VP7), including alternative forms of these proteins (eg. VP7a, VP7b, etc.). It may be possible to use more than one protein type to deliver antigens (eg. VP2, VP5, VP7). Moreover, VLPs based on alternative BLU serotypes can be used



for successive immunisations to evade the anti-BLU response elicited in a primary vaccination. This is another novel feature of this system not currently available in other antigen delivery systems.

The CLPs and VLPs of bluetongue viruses offer several particular advantages over other systems.

- Large quantities can be produced due to the expression capabilities of baculovirus vectors (ca. 20–30 mg per litre of culture, produced in serum-free medium, stable to freeze-drying, etc.).
- CLPs and VLPs can be purified using a one-step generic protocol based on the physical properties of the particle (gradient centrifugation of cell lysates).
- They are devoid of any detectable amount of insect or baculovirus proteins, RNAs, or DNAs.
- The purification procedure is gentle enough to maintain the morphological structure of the particles in their native conformations. The particles cannot replicate although multiple epitopes could be accommodated.
- Most importantly, VLPs have inherent properties of inducing both B cell and T cell responses in vertebrate hosts.

## References

- Belyaev, A.S., Hails, R.S. and Roy, P. 1995. High-level expression of five foreign genes by single recombinant baculovirus. *Gene*, 156, 229–233.
- Belyaev, A.S. and Roy, P. 1993. Development of baculovirus triple and quadruple expression vectors: co-expression of three or four bluetongue virus proteins and the synthesis of bluetongue virus-like particles in insect cells. *Nucleic Acids Research*, 21, 1219–1223.
- Bishop, D.H.L. 1992. Baculovirus expression vectors. In: *Seminars in Virology*. Saunders Scientific Publications, 3, 253–264.
- Erasmus, B.J. 1990. Bluetongue virus. In: *Dinter, Z. and Morein B. ed., Virus infections of ruminants*. Amsterdam, Elsevier Biomedical Press, 21, 227–237.
- French, T.J., Marshall, J.J.A. and Roy, P. 1990. Assembly of double-shelled, virus-like particles of bluetongue virus by the simultaneous expression of four structural proteins. *Journal of Virology*, 64, 5695–5700.
- French, T.J. and Roy, P. 1990. Synthesis of bluetongue virus (BTV) core-like particles by a recombinant baculovirus expressing the two major structural core proteins of BTV. *Journal of Virology*, 64, 1530–1536.
- Grimes, J., Basak, A., Roy, P. and Stuart, D. 1995. The crystal structure of bluetongue virus VP7; implications for virus assembly. *Nature*, 373, 167–170.
- Hayama, E. and Li, J.K.-K. 1994. Mapping and characterization of antigenic epitopes and the nucleic acid-binding domains of VP6 protein of bluetongue viruses. *Journal of Virology*, 68, 3604–3611.
- Hewat, E.A., Booth, T.F., Loudon, P.T. and Roy, P. 1992a. 3-D reconstruction of bluetongue virus core-like particles by cryo-electron microscopy. *Virology*, 189, 10–20.
- Hewat, E.A., Booth, T.F. and Roy, P. 1992b. Structure of bluetongue virus particle by cryo-electron microscopy. *Journal of Structural Biology*, 109, 61–69.
- 1994. Structure of correctly self-assembled bluetongue virus-like particles. *Journal of Structural Biology*, 112, 183–191.
- Hirasawa, T. and Roy, P. 1990. The complete nucleotide sequence of VP5 of a strain of bluetongue virus of serotype 2 isolated in the USA reveals its close relationship with a virus of serotype 1 isolate in Australia. *Virus Research*, 15, 107–112.
- Huisman, H., Van Der Walt, N.T., Cloete, M. and Erasmus, B.J. 1987. Isolation of a capsid protein of bluetongue virus that induces a protective immune response in sheep. *Virology*, 157, 172–179.
- Inumaru, S. and Roy, P. 1987. Production and characterization of the neutralization antigen VP2 of bluetongue virus serotype 10 using a baculovirus expression vector. *Virology*, 157, 472–479.
- Le Blois, H., Fayard, B., Urakawa, T. and Roy, P. 1991. Synthesis and characterization of chimeric particles between epizootic haemorrhagic disease virus and bluetongue virus: functional domains are conserved on the VP3 protein. *Journal of Virology*, 65, 4821–4831.
- Loudon, P.T., Hirasawa, T., Oldfield, S., Murphy, M. and Roy, P. 1991. Expression of outer capsid protein VP5 of two bluetongue viruses, and synthesis of chimeric double-shelled virus-like particles using combination of recombinant baculovirus. *Virology*, 182, 793–801.
- Loudon, P.T. and Roy, P. 1991. Assembly of five bluetongue virus proteins expressed by recombinant baculoviruses: inclusion of the largest protein VP1 in the core and virus-like particles. *Virology*, 180, 798–802.
- 1992. Interaction of nucleic acids with core-like and sub-core-like particles of bluetongue virus. *Virology*, 191, 231–236.
- Mertens, P.P.C., Brown, F. and Sanger, D.V. 1984. Assignment of the genome segments of bluetongue virus type 1 to the proteins which they encode. *Virology*, 135, 207.
- Oldfield, S., Hirasawa, T. and Roy, P. 1991. Sequence conservation of the outer capsid protein, VP5, of bluetongue virus, a contrasting feature to the outer capsid protein VP2. *Journal of General Virology*, 72, 449–451.
- Prasad, B.V.V., Yamaguchi, S. and Roy, P. 1992. Three-dimensional structure of single-shelled bluetongue virus. *Journal of Virology*, 66, 2135–2142.
- Roy, P. 1992. Bluetongue virus proteins. *Journal of General Virology*, 73, 3051–3064.
- Roy, P. 1996. *Orbiviruses and their replication*. In: *Field's Virology* (ed. B.N. Fields) in press.
- Roy, P., Adachi, A., Urakawa, T., Booth, T.F. and Thomas, C.P. 1990b. Identification of bluetongue virus VP6 protein as a nucleic acid-binding protein and the localization of VP6 in virus-infected vertebrate cells. *Journal of Virology*, 64, 1–8.
- Roy, P., Bishop, D.H.L., LeBlois, H. and Erasmus, B.J. 1994a. Long-lasting protection of sheep against bluetongue challenge after vaccination with virus-like particles: evidence for homologous and partial heterologous protection. *Vaccine*, 1, 805–811.
- Roy, P., Callis, J. and Erasmus, B.J. 1994b. Protection of sheep against bluetongue disease after vaccination with core-like and virus-like particles: evidence for homolo-

- gous and partial heterologous protection. In: USA Health Association, Proceedings 97th Annual Meeting, 88–97.
- Roy, P., French, T.J. and Erasmus, B.J. 1992. Protective efficacy of virus-like particles for bluetongue disease. *Vaccine*, 1, 28–32.
- Roy, P., Marshall, J.J.A. and French, T.J. 1990a. Structure of bluetongue virus genome and its encoded proteins. In: Roy, P. and Gorman, B.M. ed., *Bluetongue viruses. Current Topics in Microbiology and Immunology*, vol. 162, Springer-Verlag, Heidelberg, 43–87.
- Roy, P., Urakawa, T., van Dijk, A.A. and Erasmus, B.J. 1990c. Recombinant virus vaccine for bluetongue disease in sheep. *Journal of Virology*, 64, 1998–2003.
- Urakawa, T., French, T.J., Adachi, Y., Fukusho, A., LeBlouis, H., Flaman, M., Mertens, P. and Roy, P. 1994. Synthesis of recombinant baculoviruses expressing the outer capsid protein VP2 of five BTV serotypes and the induction of neutralizing antibodies to homologous and heterologous BTV serotypes. *Virus Research*, 31, 149–161.
- Yang, Y.Y. and Li, J.K. 1992. Complete genomic sequences of the gp5 protein gene of bluetongue virus serotype 11 and 17. *Virus Research*, 23, 163–171.

# Bluetongue Recombinant Vaccines

S.J. Johnson\* and P. Roy†

## Abstract

Bluetongue virus-like particles (VLPs) and core-like particles (CLPs) were administered to Merino sheep to assess the potential of the particles as a vaccine against bluetongue. Sheep given 2 doses of 10 µg VLPs at a 35-day interval produced group and homologous neutralising antibodies. Two weeks after the second dose the sheep were resistant to challenge with homologous virus but showed little resistance to challenge with virulent heterologous virus. Sheep inoculated twice at a 35-day interval with 10 µg CLPs showed strong group antibody response but no neutralising antibodies. These sheep were resistant to challenge with both homologous and heterologous virus when challenged 14 days after the second dose.

FOLLOWING the initial discovery of bluetongue virus (BLU) in Australia (St. George et al. 1978) and the subsequent identification of additional serotypes (St. George et al. 1980; Gard et al. 1985, 1987a, b), some Australian serotypes were found to be pathogenic for Merino sheep (Johnson et al. 1989; Melville and Gard 1990).

Attenuated vaccines being developed in Australia were teratogenic (Johnson et al. 1991; Flanagan and Johnson 1996). Production of non-replicating recombinant double-shelled virus-like particles of BLU (French et al. 1990), lacking nucleic acid, resulted in the correct spatial arrangement of BLU antigenic proteins necessary for successful vaccines. Preliminary vaccine studies using recombinant proteins in South Africa showed promising results (Roy et al. 1990, 1992) and the particles were imported into Australia to assess their efficacy against Australian BLU serotypes in Merino sheep.

## Materials and Methods

### Animals

Three-year-old Peppin Merino wethers from the Queensland Department of Primary Industry's Toorak Research Station were used in all trials. All sheep tested

seronegative to BLU by enzyme linked immunosorbent assay (ELISA). Animals were housed in an isolation unit where food and water were available ad lib.

### Regimen

Sheep were vaccinated twice (on day 0 then on day 21 or 35) with 10 µg recombinant proteins. An equal volume of Incomplete Seppic adjuvant 50 was used on each occasion. Control sheep received only adjuvant. From all sheep, 10 mL of blood was taken every seven days before challenge and daily for 18 days after challenge.

Challenge viruses had been recovered from sentinel cattle in Northern Territory and passaged three times in sheep only. Each sheep received 10 mL (5 mL intravenously, 5 mL subcutaneously) of infected blood containing  $10^{4.0}$  TCID<sub>50</sub> virus per mL. After challenge sheep were examined clinically and temperatures recorded daily and haematological values measured every second day.

Postchallenge viraemia was estimated by inoculating serial 10-fold dilutions (10<sup>-2</sup> to 10<sup>-7</sup>) of sonicated blood into embryonated chicken embryos (ECE), using six embryos per dilution. The numbers of embryos dying per dilution on days 3 to 7 post-inoculation were used to calculate the 50% chicken embryo lethal dose end points by the method of Reed and Muench (1938). Serology was carried out by standard methods (St. George 1981).

### Results Virus-like Particles

Forty sheep were used (20 vaccinates, 20 controls). VLPs contained VP2, VP5, VP3 and VP7 of Austral-

\* Queensland Department of Primary Industries, Oonoonba Veterinary Laboratory, PO Box 1085, Townsville, Queensland 4810, Australia.

† Natural Environment Research Council, Institute of Virology and Environmental Microbiology, Mansfield Road, Oxford OX1 3SR, United Kingdom.

ian BLU1. Vaccinations were given at a 35-day interval: on day 77 after secondary vaccination half of each group was challenged with Australian BLU1 and half with Australian BLU23.

### Serology

Only 13 sheep (65%) reacted in ELISA after primary vaccination, but all sheep were positive by day 28 after secondary vaccination. No neutralising antibodies were detected in any sheep after primary vaccination. Ten sheep (50%) had detectable neutralising titres by day 28 after secondary vaccination and 12 (60%) by day 47 after secondary vaccination (Table 1).

### Temperature

The temperature response of vaccinates was significantly less than that of controls ( $P < 0.01$ ) following challenge with BLU1, but there was no significant difference in temperature response after challenge with BLU23 (Fig. 1).

### Haematology

Total leucocyte counts were lower in controls than in vaccinates for both challenge groups (Fig. 2).

**Table 1.** Serological status of sheep vaccinated with baculovirus-expressed recombinant bluetongue virus-like particles on days after primary and secondary vaccination.

Sheep no.	Days after secondary vaccination																	
	d 21 APV		7			28			34			47			77			
	A	E	A	E	S	A	E	S	A	E	S	A	E	S	A	E	S	
915	+	-	++	38	10	+++	63	5	++	73	5	+	33	60	+	39	160	
916	+	-	+++	51	-	+++	50	-	+++	60	-	+++	52	-	+++	53	-	
617	++	-	+++	49	-	+++	45	-	++	42	-	+	40	-	+	67	-	
920	+	-	+++	32	-	+++	45	10	++	57	-	+	44	10	+	46	10	
921	-	-	+++	28	-	+++	47	-	+++	57	-	+++	45	-	+++	32	-	
922	+++	12	+++	42	-	+++	41	-	+++	43	-	+++	43	-	+++	51	-	
924	+	-	+++	52	10	+++	60	5	+++	60	5	++	43	10	+++	47	10	
926	+	2	+++	48	10	++	47	-	++	46	-	+	46	-	++	57	-	
927	-	-	+++	40	-	+++	56	-	++	52	-	++	52	-	++	54	-	
928	+++	37	+++	53	-	+++	60	-	+++	44	-	+++	48	-	+++	61	-	
929	-	-	++	35	-	+++	42	-	++	42	-	+	40	-	++	51	-	
931	+++	27	+++	52	-	+++	48	-	+++	51	-	+++	46	40	+++	53	10	
938	+	-	+++	50	-	+++	53	5	++	50	5	NS	NS	30	++	46	40	
945	+	-	+++	38	15	+++	44	30	+	40	10	+	48	60	+	46	40	
947	-	-	-	37	-	-	58	-	-	38	-	-	28	10	-	20	-	
950	-	-	+++	37	5	+++	45	10	+	61	5	+	48	60	+	52	60	
951	-	-	-	-	-	++	36	5	+	48	5	+	55	40	+	40	5	
954	-	-	+++	49	10	+++	40	5	++	42	5	+++	46	160	+++	53	120	
955	+++	16	+++	32	10	+++	53	5	++	56	5	+++	43	120	++	54	160	
960	-	-	+++	64	5	+++	50	5	+++	52	5	+++	52	120	+++	53	120	

A agar gel immunodiffusion test  
 E ELISA  
 S serum neutralisation test  
 APV after primary vaccination  
 ASV after secondary vaccination  
 NS no sample

## Clinical signs

Vaccinated sheep showed no clinical signs of blue-tongue after challenge with BLU1. Controls challenged with BLU1 showed mild hyperaemia of buccal and nasal mucosa and transient lameness. All sheep challenged with BLU23 showed moderate hyperaemia of buccal and nasal mucosa, serous nasal discharge, lameness, mild facial and subventral oedema, and transient dyspnoea (Figs. 3, 4, 5, 6 and 11). One (10%) control sheep died of severe blue-tongue disease on day 17 postchallenge.

## Postchallenge viraemia

Postchallenge viraemia was significantly lower ( $P < 0.01$ ) in vaccinates than in controls after day 6 postchallenge for sheep challenged with BLU1, although there was no significant difference in level of postchallenge viraemia between vaccinates and controls challenged with BLU23 (Fig. 7).

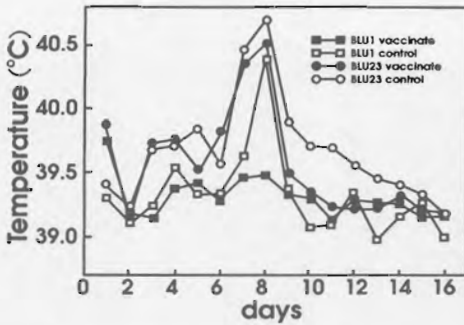

Figure 1. Group mean temperatures after challenge with Australian BLU1 and BLU23 in sheep vaccinated with baculovirus-expressed recombinant BLU virus-like particles.

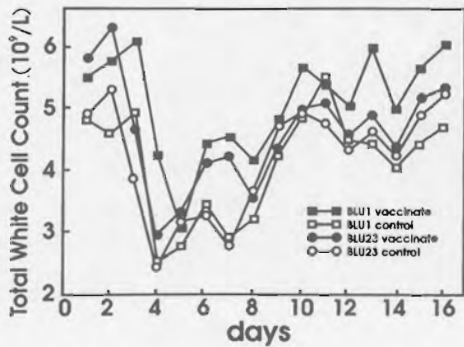

Figure 2. Group mean total leucocyte counts after challenge with Australian BLU1 and BLU23 in sheep vaccinated with baculovirus-expressed BLU virus-like particles.



Figure 3. Head of a Merino sheep infected with BLU23 showing severe oedema.



Figure 4. Buccal cavity of a Merino sheep infected with BLU23 showing hyperaemia and haemorrhage.



Figure 5. Thorax of Merino sheep infected with BLU23 showing hydrothorax.



Figure 6. Thorax of a sheep which died from BLU23 infection, showing haemorrhages in the wall of the aorta.

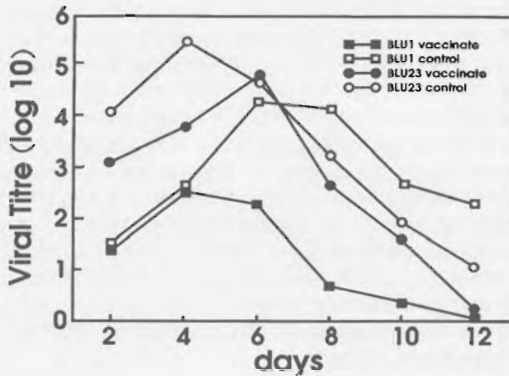

Figure 7. Group mean viraemia following challenge with Australian BLU1 and BLU23 in sheep vaccinated with baculovirus-expressed recombinant BLU-like particles.

## Results Core-like Particles

Thirty sheep were used (20 vaccinates, 10 controls). Vaccinations were given at a 21-day interval and half of each group were challenged with BLU1 and half with BLU23 on day 14 after secondary vaccination.

### Serology

Fifteen (75%) vaccinates were positive in ELISA by day 11 after primary vaccination and all were positive by day 14 after secondary vaccination (Table 2). No neutralising antibodies were detected in any sheep after either vaccination.

Table 2. Serological status of sheep vaccinated with baculovirus-expressed recombinant bluetongue core-like particles on days after primary and secondary vaccination.

Sheep No.	Serological status					
	Day 11 APV			Day 14 ASV		
	A	E	S	A	E	S
<b>Vaccinates</b>						
1046	+	91	-	++	84	-
1050	+	41	-	+++	117	-
1051	+	84	-	++	91	-
1053	+	90	-	+++	113	-
1056	++	94	-	+++	110	-
1061	+	0	-	++	114	-
1064	++	102	-	+++	90	-
1066	-	0	-	-	111	-
1083	++	65	-	++	81	-
1086	+	0	-	++	103	-
1049	+	69	-	++	98	-
1052	+	0	-	++	83	-
1054	-	0	-	+++	96	-
1055	+	61	-	+++	105	-
1057	+	86	-	+++	104	-
1058	++	66	-	+++	101	-
1060	++	78	-	+++	102	-
1079	++	56	-	+++	136	-
1084	+++	91	-	+++	143	-
1087	++	77	-	+++	96	-
<b>Controls</b>						
1047	-	0	-	-	4	-
1059	-	0	-	-	6	-
1062	-	0	-	-	11	-
1063	-	0	-	-	16	-
1065	-	0	-	-	0	-
1078	-	0	-	-	1	-
1080	-	0	-	-	14	-
1081	-	0	-	-	30	-
1082	-	0	-	-	19	-
1085	-	0	-	-	14	-

A agar gel immunodiffusion test  
 E ELISA  
 S serum neutralisation test  
 APV After Primary Vaccination  
 ASV After Secondary Vaccination

## Temperature

Vaccinated sheep showed no febrile response to challenge with either serotype whereas controls showed a febrile reaction on days 8 and 9 after challenge with both serotypes (Fig. 8).

## Haematology

There was no significant difference in TWCC between vaccinates and controls after challenge with BLU1. Control sheep had a significantly lower ( $P < 0.01$ ) TWCC than vaccinates between days 6 and 8 after challenge with serotype 23 (Fig. 9).

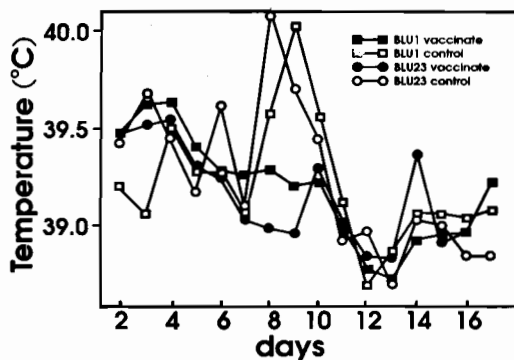

Figure 8. Group mean temperatures after challenge with Australian BLU1 and BLU23 in sheep vaccinated with baculovirus-expressed recombinant BLU core-like particles.

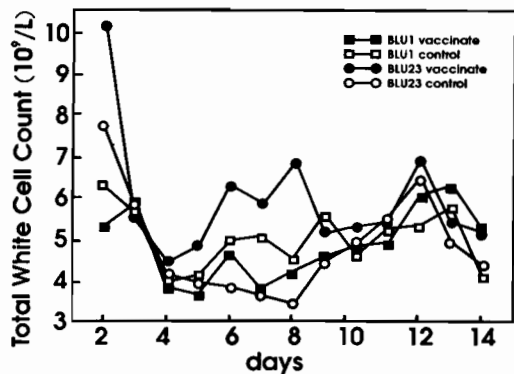

Figure 9. Group mean total leucocyte counts after challenge with Australian BLU1 and BLU23 in sheep vaccinated with baculovirus-expressed recombinant BLU core-like particles.

## Postchallenge viraemia

The level of viraemia was significantly lower ( $P < 0.01$ ) in vaccinates than in controls on days 10 and 12 and days 6 to 10 postchallenge with BLU1 and BLU23 respectively (Fig. 10).

## Clinical signs

Vaccinated sheep showed no clinical signs of blue-tongue following challenge with either serotype. Controls challenged with BLU1 showed mild signs of disease and those challenged with BLU23 showed moderate to severe signs. One (20%) of the controls challenged with BLU23 died of severe disease on day 16 after challenge.

## Discussion

Baculovirus-expressed VLPs show VP2 and VP5 in the correct structural configuration, together with VP3 and VP7 in an icosahedral structure identical to that of the BLU virion (French et al. 1990). The production of protective neutralising antibodies in sheep vaccinated with VLPs, in this study and previously (Roy et al. 1992), is strong evidence for the correct presentation of the VP2 antigen to the animal.

Even though vaccination with VLPs afforded good homologous protection, it was unable to inhibit postchallenge viraemia completely. Roy et al. (1992) achieved absence of postchallenge viraemia in sheep vaccinated with 10  $\mu$ g of VLPs but not in all sheep vaccinated with 100 and 200  $\mu$ g doses. This inability to limit postchallenge viraemia is in contrast to vaccination with live attenuated BLU (Roy et al. 1992; S.J. Johnson pers. comm.).

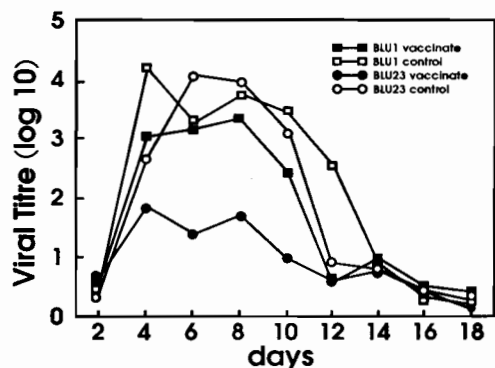

Figure 10. The level of viraemia in sheep after challenge with BLU1 and BLU23.

The ability of vaccination with CLPs to protect sheep in the absence of neutralising antibodies suggests a strong cell-mediated immune response and/or non-neutralising antibodies in protection against bluetongue viruses. In this study any cell-mediated immune response was likely to have been optimal when sheep were challenged 14 days after booster vaccination (Jeggo and Wardley 1982).

These results suggest that vaccination with a combination of VLPs and CLPs may give good homotypic and adequate heterotypic protection. However, the longevity of the heterotypic protection afforded by vaccination with CLPs needs to be ascertained.

### Acknowledgments

Robin Jack, Scott Blyth and Steve Peucker took excellent care of the experimental animals. The Australian Wool Research and Promotion Organisation supported this study financially.

### References

- Flanagan, M. and Johnson, S.J. 1996. The effects of vaccination of Merino ewes with a live attenuated Australian bluetongue virus serotype 23 at different stages of gestation. *Australian Veterinary Journal*.
- French, T.J., Marshall, J.J.A. and Roy, P. 1990. Assembly of double-shelled virus-like particles of bluetongue virus by the simultaneous expression of four structural proteins. *Journal of Virology*, 54, 5695-5700.
- Gard, G.P., Shorthose, J.E., Cybinski, D.H. and Zakrzewski, H. 1985. The isolation from cattle of 2 bluetongue viruses new to Australia. *Australian Veterinary Journal*, 62, 203.
- Gard, G.P., Shorthose, J.E., Weir, R.P. and Erasmus, B.J. 1987a. The isolation of a bluetongue serotype new to Australia. *Australian Veterinary Journal*, 64, 87.
- Gard, G.P., Weir, R.P. and Erasmus, B.J. 1987b. The isolation of bluetongue virus types 3 and 16 from northern Australia. *Australian Veterinary Journal*, 64, 388.
- Jeggo, M.H. and Wardley, R.C. 1982. The induction of murine cytotoxic T lymphocytes by Bluetongue virus. *Archives Virology*, 71, 197-206.
- Johnson, S.J., Hoffmann, D., Flanagan, M., Polkinghorne, I.G. and Bellis, G.A. 1989. Recent experience with bluetongue in Queensland. In Uren, M.F., Blok, J. and Manderson, L.H. ed., *Arbovirus research in Australia*. Proceedings 5th Symposium. CSIRO/Queensland Institute of Medical Research, Brisbane 307-309.
- Johnson, S.J., Polkinghorne, I.G., Flanagan, M. and Townsend, W.L. 1991. The Australian experience: Results of a Bluetongue Vaccination Program. In: Walton, T.E. and Osburn, B.J., ed., *Bluetongue, African horse sickness and related orbiviruses*. Proceedings 2nd International Symposium. CRC Press, Boca Raton, 868-873.
- Melville, L.F. and Gard, G.P. 1990. Bluetongue Research in the Northern Territory. In: Greenwood, P.E. ed., *Australian Advances in Veterinary Science*. Australian Veterinary Association, Artarmon, NSW, 20-22.
- Reed, L.J. and Muench, H. 1938. A simple method of estimating fifty percent endpoints. *American Journal of Hygiene*, 27, 493-495.
- Roy, P., French, T. and Erasmus, B.J. 1992. Protective efficacy of virus-like particles for bluetongue disease. *Vaccine*, 10, 28-32.
- Roy, P., Urakawa, T., Van Dijk, A.A. and Erasmus, B.J. 1990. Recombinant virus vaccine for bluetongue disease in sheep. *Journal of Virology*, 64, 1998-2003.
- St. George, T.D. 1981. Bluetongue microtitre neutralisation test. *Standard Diagnostic Techniques*, SCA Animal Health Committee. March, 1-4.
- St. George, T.D., Cybinski, D.H., Della-Porta, A.J., McPhee, D.A., Wark, M.C. and Bainbridge, M.H. 1980. The isolation of two bluetongue viruses from healthy cattle in Australia. *Australian Veterinary Journal*, 56, 562-563.
- St. George, T.D., Standfast, H.A., Cybinski, D.H., Dyce, A.L., Muller, M.H., Doherty, R.L., Carley, J.G. and Frazier, C.L. 1978. The isolation of a bluetongue virus from *Culicoides* collected in the Northern Territory of Australia. *Australian Veterinary Journal*, 54, 153-154.



# Studies on the Vaccination of Sheep with Bluetongue Virus Core-like Particles Produced by a Recombinant Baculovirus

M. Hosseini\*, R.J. Dixon\*, P.D. Kirkland<sup>†</sup> and P. Roy<sup>§</sup>

## Abstract

Bluetongue virus (BLU) core-like particles (CLPs), containing the major structural proteins VP7 and VP3 and expressed by a recombinant baculovirus, were used in a dose-response vaccination study. Six groups of four sheep were inoculated with purified CLPs in ISA-50 adjuvant, and revaccinated after three weeks. Sheep in each group were given either 1, 10, 20, 50, 100 or 200 µg CLP protein at each vaccination, while a control group of nine sheep was inoculated with adjuvant in phosphate buffered saline (PBS) alone. Sheep were bled at regular intervals to measure antibody to VP7. Eleven weeks after the first inoculation, all sheep were challenged with a virulent isolate of BLU23. Blood samples were taken to determine levels of viraemia. By 10 days post-challenge, four control sheep had developed coronitis in all feet, and by 14 days all control sheep had body temperatures greater than 40°C, although no mortalities occurred. In vaccinated sheep, fever was the only clinical sign observed. The control group had a mean clinical reaction index (CRI) of 4.1. All vaccinated groups had a reduced mean CRI ( $p < 0.05$ ), the greatest being for the 100 µg (CRI 0.82) and 200 µg groups (CRI 2.3). Seventeen sheep from control, 10, 100 and 200 µg groups were monitored for viraemia, which was detected in all animals. Compared with the seven control animals, peak viraemia was reduced by  $1 \log_{10}$  or more in three sheep from the 200 µg group and by  $1 \log_{10}$  in one sheep from the 10 µg group.

BLUETONGUE virus (BLU) is the causative agent of an insect-transmitted infectious disease of sheep, cattle, goats and wild ruminants. Twenty-four BLU serotypes have been identified to date.

Vaccination is the most cost-effective method of controlling most viral diseases. In the case of BLU infection, only live-attenuated vaccines have proven to be effective. However, the disadvantages of BLU live-attenuated vaccines include risks associated with insufficient attenuation, reversion to virulence, gene reassortment (Gibbs and Greiner 1988) and reproductive losses when vaccinating pregnant sheep (Osburn 1994b). Both attenuated and killed BLU vaccines confer serotype-specific immunity to chal-

lenge, with only some cross protection between some serotypes (Stevens et al. 1985; Stott and Osburn 1990). In regions where more than one BLU serotype is endemic, the need to provide immunity against several serotypes presents practical problems. Foremost is the issue of reduced immune responses in sheep vaccinated with multicomponent or multivalent vaccines (Erasmus 1975; Huismans 1985; Raadsma et al. 1994).

Subunit vaccines, carrying the antigenic determinants which afford protective immunity, can be obtained by recombinant DNA technology. These appear to be the most promising means of combining the safety of inactivated vaccines with the efficacy of a monovalent live-attenuated BLU vaccine. One possible vaccine is derived from a recombinant baculovirus containing the cDNA for the two major BLU core proteins, VP3 and VP7 (French and Roy 1990). The expressed product forms BLU core-like particles (CLPs) which are not serotype-specific. This paper reports that partial protection to BLU challenge can be conferred on sheep vaccinated with CLPs.

\* Department of Animal Health, University of Sydney, Camden, New South Wales 2570, Australia.

<sup>†</sup> Elizabeth Macarthur Agricultural Institute, Camden, New South Wales 2570, Australia

<sup>§</sup> Institute of Virology and Environmental Microbiology, Oxford OX1 3SR, United Kingdom.

## Materials and Methods

### Origin and purification of CLPs

*Spodoptera frugiperda* cells in suspension culture were infected by a recombinant *Autographica californica* nuclear polyhedrosis virus containing the dual-transfer vector pAcVC3.BLU-10.7.BLU-17.3 (French and Roy 1990). Forty-eight hours after infection, the cells were harvested, washed in phosphate buffered saline (PBS) and lysed in 0.05 M Tris HCl (pH 8.0) 0.15 M NaCl 0.5% Nonidet P-40. The expressed CLPs were then semipurified by ultracentrifugation through a discontinuous sucrose gradient (30–50% wt/vol in 0.2 M Tris HCl, pH 8.0). Semi-purified BLU CLPs were then purified by ultracentrifugation on a self forming continuous CsCl gradient (44% wt/vol in 0.05 M Tris HCl, pH 8.0) followed by a second CsCl discontinuous gradient (30–44% wt/vol in 0.2 M Tris HCl, pH 8.0). CLPs were checked by SDS-polyacrylamide gel electrophoresis (SDS-PAGE), filtered and concentrated using an Ultrafree-CL filter unit (10 000 NMWL, Millipore). The CLPs were resuspended in PBS and their protein concentration determined by the bicinchoninic acid (BCA) protein assay (Pierce Co.)

### Preparation of CLP vaccine

Vaccine was formulated with 10, 100 and 200 µg of CLPs and consisted of a 1:1 emulsion in Montanide Incomplete Seppic Adjuvant (ISA-50; manide oleate in mineral oil), a gift from Tall-Bennett Pty Ltd, Melbourne, Australia.

### Animals

The experimental animals comprised 25 Merino sheep of both sexes, from 2 to 4 years in age. These animals were free of BLU-serogroup antibodies as determined by a competitive enzyme linked immunosorbent assay (cELISA). Nine sheep were used as controls, eight in the 10 µg group and four in each of the 100 and 200 µg groups.

### Vaccination procedure

Vaccinated sheep were inoculated with CLPs and adjuvant (1:1) while control sheep received only PBS and adjuvant (1:1). A total volume of 2 mL per sheep was inoculated subcutaneously behind the left or right ear. Three weeks after the initial vaccination the same procedure was repeated.

### Vaccine challenge

Eleven weeks after the first vaccination, all sheep were challenged with a single inoculation, subcutaneously at the shoulder, with 1 mL heparinised sheep-passaged blood containing BLU23. This blood, from a sheep that had died from bluetongue, had been titrated in sheep to determine the minimal dose required to induce clinical signs in all sheep (data not presented).

### Blood sampling

Clotted blood was collected from all sheep three times a week, from the first day of vaccination until 10 days after the booster. Sheep were then bled at one week intervals until the challenge with BLU23. Heparinised and clotted blood samples were collected on days 5, 7, 10, 12, 14, 21 and 28 post-challenge.

### Monitoring of clinical signs

Sheep were monitored daily for body temperature and clinical signs for 14 days following the challenge with BLU23. Clinical signs were quantified by a clinical reaction index (CRI), as described by Huisman et al. (1987). A maximum score of 12 was given to a cumulative total of body temperature of more than 40.0°C from 3 to 14 days post-infection, a score from 0 to 4 each to mouth lesions, nose lesions and foot lesions (lameness, coronitis) and a score of 4 for death. These scores were added, to a maximum possible score of 28.

### Serology

Antibody to VP7 was detected by cELISA (Gard and Kirkland 1993). Briefly, 96-well flat-bottom microtitre plates (Greiner medium binding) were coated with 50 mL/well of cell culture derived antigen diluted in 0.1 M carbonate buffer (pH 9.6) and held at room temperature overnight. After washing the plates, 50 mL of a 1:10 dilution of test serum in skim milk buffer (1% skim milk in 0.5% Tween 20 in PBS) was added to duplicate wells. High and low positive and negative standards were included on each plate. The plates were then shaken and incubated at 37°C for 30 min. Following incubation, 50 mL of an anti-VP7 monoclonal antibody (MAB; CSIRO/BLU/20E9B7G2) was added to each well. After incubating the plates again for 30 to 45 min, 50 mL of peroxidase-conjugated goat anti-mouse IgG was added to each well. After incubation and washing 3% TMB substrate was added. The colour reaction was stopped by adding 1M H<sub>2</sub>SO<sub>4</sub>, the plates read at 450 nm in a microplate photometer and results expressed as percent inhibition (PI%). Values greater than or equal to 40% inhibition were defined as positive.

### Titration of antibodies after vaccination

The serogroup antibody response was quantified in some of the sheep testing positive in the cELISA. These included four sheep from the 10 µg CLP vaccinated group and two sheep each from the 100 and 200 µg groups. Sera were diluted in skim milk buffer from 1:10 dilution in doubling dilutions to 1:25600. These dilutions were then tested using the cELISA with the serum antibody titre defined as the last dilution to give 40% inhibition.

### Titration of viraemia post-challenge

Heparinised bloods were collected at 5, 7, 10, 12 and 14 days postchallenge from selected sheep (Table 1) and centrifuged. The red blood cells and/or buffy coat were collected and lysed in sterile distilled water (1:1). Appropriate dilutions ( $10^{-1}$  to  $10^{-6}$ ) were prepared in PBS. Each dilution was injected into five embryonated chicken eggs (ECE) to determine the end-point for each sample. After 5 days the embryonic liver was harvested into a solution containing 1

mL of PBS-Tween (0.5% Tween 20 in PBS) and homogenised. Supernatant (100 mL) from each liver homogenate was passed into each of two tube cultures of *Aedes albopictus* (AA) mosquito cells when the cells were 50–70% confluent. After one week, 100 mL of a suspension of cells was passaged to duplicate BHK21 cell cultures at 50% confluency. All tubes were examined daily for seven days for cytopathic effects (CPE). Those tubes which showed CPE during that time were stored at 4°C. Tubes which showed no signs of CPE were passaged twice

**Table 1.** Clinical response index (CRI), viraemia<sup>a</sup> and serogroup antibody (SAb) titres of sheep vaccinated with CLPs and challenged with BLU23.

Group	Sheep no.	CRI	Group Mean CRI	Viraemia 5 DPI	Group mean viraemia 5 DPI	Viraemia 7 DPI	Group mean viraemia 7 DPI	Viraemia 14 DPI	SAb Titre 3 WPIV	SAb Titre 10 WPIV
control	C4	2.6		4.89		3.78		nil	-ve	-ve
	C5	1.8		3.54		3.50		1.50	-ve	-ve
	C7	3.9		5.36		5.02		1.81	-ve	-ve
	C9	4.8		5.20		4.07		1.50	-ve	-ve
	C10	2.2		2.50		4.89		2.09	-ve	-ve
	8A	4.4		nd		nd		nd	-ve	-ve
	8B	5.5		nd		nd		nd	-ve	-ve
	8C	6.4		4.90		4.39		nil	-ve	-ve
	8D	5.9		5.30		4.50		nil	-ve	-ve
			4.1 ± 1.7		4.5 ± 1.1		4.3 ± 0.56			
10 µg	11	1.9		3.60		4.40		nil	1:400	>1:25600
	12	1.8		nd		nd		nd	nd	nd
	13	0.5		nd		nd		nd	nd	nd
	14	4.2		4.13		3.13		nil	1:200	>1:25600
	71	1.3		nd		nd		nd	nd	nd
	72	2.0		1.78		3.54		nil	1:1600	1:25600
	73	2.9		4.42		3.12		2.12	1:1600	1:12800
	74	6.4		nd		nd		nd	nd	nd
			2.6 ± 1.9		3.48 ± 1.2		3.54 ± 0.6			
100 µg	41	0.8		5.50		4.13		nil	1:200	1:12800
	42	1.0		nd		nd		nd	nd	nd
	43	0.4		nd		nd		nd	nd	nd
	44	1.1		4.20		5.89		1.78	1:100	1:12800
				0.82 ± 0.3		4.85 ± 0.9		5.01 ± 1.24		
200 µg	81	1.2		3.66		3.57		2.21	nd	nd
	82	3.2		4.44		4.40		nil	1:400	1:6400
	83	2.6		3.62		3.60		2.54	nd	nd
	84	2.3		5.60		4.44		1.94	1:3200	1:12800
				2.4 ± 0.8		4.33 ± 0.93		4.0 ± 0.48		

<sup>a</sup> Viraemia expressed as log<sub>10</sub> chick embryo infectious dose<sub>50</sub>/mL

DPI days post infection

WPIV weeks post initial vaccination

nd not done

in BHK21 cells. After three passages, BHK21 cells that were not showing CPE were considered to be BLU-negative. The BLU titre in the blood was then calculated as  $\log_{10}$  chick embryo infectious dose<sub>50</sub> ( $\log_{10}$  CEID<sub>50</sub>)/mL.

### Statistical analyses

An approximate Student's *t* test across groups for the CRI was carried out because of the wide variance within groups. For the peak of viraemia at either day 5 or day 7 post-challenge, a Student's *t* test was used to analyse group results.

## Results

### Clinical reaction index (CRI)

Sheep vaccinated with CLPs and challenged with virulent BLU23 had a significant reduction ( $p < 0.05$ ) in the severity of clinical signs as measured by their group mean CRI (Table 1). While control sheep showed fever and coronitis, only fever was observed in vaccinated sheep.

Control sheep had a group mean CRI of  $4.1 \pm 1.7$ . The CRI for this group represented a fever in all animals exceeding 40°C for 2–5 days and coronitis in four out of nine sheep at seven days after challenge. No other signs were observed and no deaths occurred.

Sheep vaccinated with 10 µg CLPs had a group mean CRI of  $2.6 \pm 1.9$ . All sheep from this group manifested fever exceeding 40°C for 1–4 days. For the 100 µg group the group mean CRI was  $0.82 \pm 0.3$ , due to fever exceeding 40°C for 1–2 days. The 200 µg group had a mean CRI of  $2.4 \pm 0.8$ , with fever exceeding 40°C being observed for 3–4 days.

Within the vaccinated groups there was some individual variation in fever and its duration. In the 100 µg group fever did not exceed 41°C, whereas in five out of eight sheep in the 10 µg group, and in three out of four sheep in the 200 µg group, fever exceeded 41°C. For the control group five out of nine sheep had a rectal temperature greater than 41°C.

### Viraemia

Seventeen animals were tested for viraemia. Only the 10 µg group had a statistically significant mean titre ( $p < 0.05$ ) lower than the titre for the control group ( $4.3 \pm 0.56$  CEID<sub>50</sub>) at 7 days post-infection (Table 1). However, at seven days after challenge most vaccinated sheep (6/10) had titres less than the mean for the control animals. Two animals (14 and 73) from the 10 µg group were approximately two standard deviations less than the mean for the control group, and a further three (no. 72 from the 10 µg group, and 81 and 83 from the 200 µg group) were at least one standard deviation less.

Vaccination did not affect when viraemia peaked or its duration. Thirteen animals (7/10 vaccinated and 6/7 controls) had a peak viraemia by day 5, while the remaining four peaked by day 7. Viraemia was undetectable in five animals (4 vaccinated, 1 control) by day 12, and by day 14 in three animals (1 vaccinated, 2 controls). Nine animals (5 vaccinated, 4 controls) were still viraemic at 14 days after challenge.

### Serogroup antibody titration

Sera from all vaccinated sheep were tested by cELISA at the standard dilution of serum (1:10) after the first and second vaccinations for eight weeks to determine the serogroup antibody response. All vaccinated sheep became positive by 2 weeks after the initial vaccination.

The antibody titres of eight vaccinated sheep (four sheep from 10 µg group, two sheep from 100 µg group and two sheep from 200 µg group) were determined by cELISA (Table 1). There was a dramatic increase in antibody titres after the booster vaccination.

There was a negative correlation between the dose of CLPs and the antibody titre. One week before virus challenge, the titres for the 10 µg group were 1:25600 for three of the four sheep (one sheep 1:12800), 1:12800 for sheep in the 100 µg group, and 1:12800 and 1:6400 for sheep in the 200 µg group.

Overall, then, in this study sheep in the 10 µg group had the highest antibody titre, the lowest titre of viraemia but the least reduction in CRI. In the 100 µg group, sheep had intermediate antibody titres, the highest titre of viraemia but the greatest reduction in CRI. Sheep in the 200 µg group had the lowest antibody titre, moderate titres of viraemia (closest to the control group) and a moderate reduction in CRI.

## Discussion

The vaccination of Merino sheep with recombinant baculovirus expressed CLPs resulted in a significant reduction ( $p < 0.05$ ) in clinical signs after challenge. This reduction was primarily due to the absence of coronitis and a reduction in the degree of fever in vaccinated sheep compared to controls.

Although there was a reduction in viraemia up to 2  $\log_{10}$  CEID<sub>50</sub> for some individual vaccinated animals, this reduction was not consistent on a group basis, and for most groups the mean reduction was not significant. The statistically significant reduction in viraemia observed in the 10 µg group will need further investigation to determine whether this is reproducible, as only small numbers of animals were included in each group. Interestingly, there was no correlation between the titre of viraemia and the clinical response after challenge.

Titres of antibody to VP7 appeared to be inversely proportional to the quantity of CLPs inoculated into the sheep. The highest titres were found for animals within the 10 µg groups: animals inoculated with 100 mg and 200 µg CLPs had lower titres of anti-VP7 antibody as determined by the eELISA. Furthermore, maximum titres did not occur until after the second vaccination.

CLPs have been proposed as having potential as a broad spectrum BLU vaccine. Our results demonstrate some of this potential. Faced with an outbreak of BLU infection, where type-specific vaccines were not available or the serotypes unknown, CLPs could be used to ameliorate the impact of the infection. However, the reduction in viraemia observed in vaccinated animals may not be sufficient to help control spread of the infection. Nevertheless, any amelioration in disease would have both economic and animal welfare benefits, in terms of reduced mortalities and increased growth rates and wool production.

In contrast to live attenuated vaccines, CLP vaccines have several advantages conferred by their non-infectious nature. CLP vaccines do not have the risks inherent in all live vaccines of reversion to virulence, insufficient attenuation, genetic reassortment and a range of reproductive losses and disorders (Gibbs and Greiner 1988; Van Dijk 1993; Osburn 1994b). Reversion to virulence by vaccine viruses, or genetic reassortments, are a real risk in endemic areas. Vaccination during an outbreak in these regions is not recommended because of the possibility of passaging attenuated viruses through insects (Doel 1993), or of reassortment between attenuated serotypes and/or field isolates. For these reasons, existing vaccines should be administered out before the beginning of seasonal vector activity (Osburn 1994a), whereas subunit vaccines, such as CLP vaccines, can be used at any time. CLPs could also be engineered to distinguish between vaccinated and BLU-infected sheep by the development of an appropriate ELISA, following a similar approach to that developed for rinderpest (Ismail et al. 1993). Multivalent BLU vaccines may also produce immunological interference or antigenic competition (Huisman 1985). Vaccination by CLPs may be a temporary yet effective approach until this problem is overcome.

It is well recognised that anti-VP7 antibody does not protect against BLU infection. The apparent reduction in clinical disease following vaccination with CLPs suggests that other immune mechanisms are important in ameliorating the clinical impact of BLU infection in vaccinated animals. Studies in progress are investigating the role of cell-mediated immunity in affecting the clinical outcomes induced by CLP vaccination. CLPs themselves could be useful probes for sheep immune responses to BLU infection.

## Acknowledgments

K. Abbott carried out the statistical analyses. C. Horwitzky, A. Jugow, R. Davis, D. Sanders and M. Wu provided technical assistance.

## References

- Doel, T.R. 1993. Exotic virus vaccine. In: Peters, A.R., ed., *Vaccines for Veterinary Applications*. Butterworth-Heinemann, Oxford, 225–256.
- Erasmus, B.J. 1975. The control of bluetongue in an enzootic situation. *Australian Veterinary Journal*, 51, 209–210.
- French, T.J. and Roy, P. 1990. Synthesis of bluetongue virus (BTV) core-like particles by a recombinant baculovirus expressing the two major structural core proteins of BTV. *Journal of Virology*, 64, 1530–1536.
- Gard, G.P. and Kirkland, P.D. 1993. Bluetongue: virology and serology. In: Corner, L.A. and Bagust, T.J. ed., *Australian standard diagnostic techniques for animal diseases*. CSIRO for the Standing Committee on Agriculture and Resource Management, East Melbourne.
- Gibbs, E.P.J. and Greiner, E.C. 1988. Bluetongue and epizootic hemorrhagic disease. In: Monath, T.P. ed., *Arboviruses*. Vol. II. CRC Press, Boca Raton, Florida, 39–70.
- Huisman, H. 1985. The use of recombinant DNA technology for development of a bluetongue virus subunit vaccine. *Onderstepoort Journal of Veterinary Research*, 52, 149–151.
- Huisman, H., Van Der Walt, N.T., Cloete, M. and Erasmus, B.J. 1987. Isolation of capsid protein of bluetongue virus that induces a protective immune response in sheep. *Virology*, 157, 172–179.
- Ismail, T., Ahmad, S., Saliki, J., Mebus, C. and Yilma, T. 1993. Differential diagnosis between rinderpest-virus vaccinated and infected animals using the nucleocapsid protein expressed in baculovirus. In: United States Animal Health Association, *Proceedings of the 97th Annual Meeting*. US Animal Health Association, Las Vegas, 107–117.
- Osburn, B.I. 1994a. Bluetongue virus. *Veterinary Clinics of North America: Food Animal Practice* 10, 547–560.
- 1994b. The impact of bluetongue virus on reproduction. *Comparative Immunology Microbiology and Infectious Diseases*, 17, 189–196.
- Raadsma, H.W., O'Meara, T.J., Egerton, J.R., Lerbach, P.R. and Schwatzkoff, C.L. 1994. Protective antibody titres and antigenic competition in multivalent *Dichelobacter nodosus* fimbrial vaccines using characterised rDNA antigens. *Veterinary Immunology and Immunopathology*, 40, 253–274.
- Stevens, D.R., Stott, J., Osburn, B.I., Giles, R., Wiesehahn, G.P. and Barber, T.L. 1985. Potency and efficacy of inactivated bluetongue virus vaccines. In: Barber, T.C., Jochim, M.S. and Osburn, B.I. ed., *Bluetongue and related orbiviruses*. Progress in Clinical and Biological Research, vol. 178. Alan R. Liss Inc. New York, 649–652.
- Stott, J.L. and Osburn, B.I. 1990. Immune response to bluetongue virus infection. *Current Topics in Microbiology and Immunology*, 162, 163–178.
- Van Dijk, A.A. 1993. Development of recombinant vaccines against bluetongue. *Biotechnology Advances*, 11, 1–12.

# Estimations of the Divergence of Bluetongue Viral Populations in Indonesia on the Basis of Virus Isolation and PCR Sequence Analysis

I. Sendow\*, I. Pritchard<sup>†</sup>, P.W. Daniels<sup>†</sup> and B.T. Eaton<sup>†</sup>

## Abstract

In Indonesia, seven serotypes of bluetongue virus (BLU) have been isolated, mostly from the blood of sentinel cattle but also from *Culicoides* vectors and mosquitoes. Three serotypes have also been isolated from locations some 4000 km apart in eastern and western Indonesia. How mobile are virus populations in such a large country? Does each virus serotype comprise one large homogenous national population or are there detectable differences at the molecular level among isolates from different sources? Are there detectable differences from a single source over relatively short periods of time? Differences may indicate separate subpopulations of viruses, and give a means of studying aspects of their epidemiology. This study compared the nucleotide sequences of specific regions of the viral genomes of Indonesian isolates of bluetongue virus amplified by polymerase chain reaction (PCR).

BLUETONGUE viruses (BLU) are members of the *Orbivirus* genus of the family Reoviridae. Twenty-four BLU serotypes have been defined by their reactions in serum neutralisation tests (Gorman et al. 1983). The viruses contain ten double-stranded segments of RNA within a double-layer capsid. The inner capsid comprises two major proteins, VP3 and VP7, and three minor proteins, VP1, VP4 and VP6. The outer capsid comprises two proteins, VP2 and VP5 (Verwoerd et al. 1970, 1972; Huismans 1979). Non-structural proteins, NS1, NS2 and NS3, have also been identified (Mertens et al. 1984; Eaton and Gould 1987).

Serological studies have shown that bluetongue viruses are widespread throughout the islands of Indonesia (Sendow et al. 1986, 1991a). Reactors were found in cattle, buffaloes, goats and sheep sera collected from all the major islands. In West Java, monitoring of sentinel cattle in 1987 and 1988 yielded arboviral isolates which were subsequently confirmed as BLU7 and 9 (Sendow et al. 1991b). At this site in 1990, five BLU serotypes were isolated from sentinel cattle over a six month period (Sendow

et al. 1993a, c). In Irian Jaya, 4000 km to the east of the West Java site, similar serotypes were isolated during the same period, suggesting that these viruses were distributed in widely separate areas of Indonesia (Sendow et al. 1993b). How mobile are these viral populations in such a large country? Does each serotype comprise one large homogenous national population or are the isolates representatives of smaller populations from different sources?

To address such questions for orbiviruses, including BLU, techniques have been developed to analyse molecular differences among isolates. Nucleotide sequences of relatively conserved regions of viral RNA gene segments can be analysed (Gould et al. 1989; Gould and Pritchard 1991). By focussing on RNA gene segment 3, coding for the inner capsid protein VP3, it has been shown that BLU viruses fall into distinct topotypes, and that within topotypes there is further variation correlating with geographic region of isolation.

The aim of this study was to compare the sequence analyses of RNA segment 3 (Gould and Pritchard 1991) of bluetongue isolates with their geographic origin within Indonesia for epidemiological studies. On the basis of such knowledge it may be possible to investigate further the relationships among Indonesian viruses and those from other countries in the region, especially northern Australia.

\* Research Institute for Veterinary Science, PO Box 52, Bogor 16151, Indonesia.

<sup>†</sup> CSIRO Australian Animal Health Laboratory, PO Bag 24, Geelong, Victoria 3220, Australia.

Australia and Indonesia have had co-operative programs in veterinary arbovirology for several years, incorporating both virus and vector studies (Daniels et al. 1995). This work enhances Australian preparedness for the possible entry of new viral serotypes and insect vectors into Australia, while Indonesia benefits from a greater understanding of its animal health status. The information also helps stabilise trade in livestock and livestock products, contributing to the prosperity of both countries.

## Geographic Distribution of Serotypes

### Serological studies

Sendow et al. (1991a) reported on the first national serological survey for several BLU serotypes, using sera stored in a serum bank (Young et al. 1985). Reactors were detected to BLU1, 12, 17, 20 and 21, although overall prevalences to BLU1, 12 and 17 were low (< 5%). Since titres of these sera were also low (< 1:16), and most also reacted with other serotypes at higher titre, cross-reactions were considered a possibility for these three serotypes. However, previous localised studies in two provinces, East Java and Bali, had detected high prevalences of antibodies to BLU1 and 20, and a low (< 5%) prevalence of reactors to BLU12 (Miura et al. 1982). Overall the serological data from the two studies indicated a high probability of infections with BLU1, 20 and 21, with the majority of the 24 BLU serotypes untested.

Sendow et al. (1991a) detected reactors to BLU1 only in Java, with BLU 20 and 21 reactors being detected on all islands studied, from Sumatra in the north-west through Java, Kalimantan, Sulawesi to Timor in the south-east.

### Viral isolations

The original isolations of BLU7 and 9 were from Depok in West Java. Subsequently, BLU1, 12, 21 and 23 were isolated from sentinel cattle at the same site, as well as a second isolate of BLU9 (Sendow et al. 1993a). These results substantiated the observation of antibodies to BLU1 and 12, although there have been no further serotype-specific serological studies. Hence bluetongue virus serotypes confirmed in Indonesia are BLU1, 7, 9, 12, 21 and 23, with serological evidence for BLU20. Recently, further BLU isolates from West Java have been identified, and an isolate of BLU3 has been confirmed (Sendow unpublished data).

Although sentinel cattle have been monitored for virus isolation from other sites, including Bali, West Timor and two sites in Irian Jaya (Daniels et al. 1995), bluetongue viruses have been confirmed from only one other district, Jayapura in Irian Jaya. There BLU1, 21 and 23 were reported (Sendow 1993b) with an isolate of BLU16 recently confirmed (Sen-

dow unpublished data). This finding of similar serotypes in the east as well as the west of Indonesia (Fig. 1) is of great importance epidemiologically. The finding of BLU1 in both locations indicates a broad distribution of this serotype, contrary to the previous serological evidence. The results also support the widespread distribution of BLU21, as suggested by the serological data, and indicate that an additional serotype, BLU23, may have a similarly wide distribution. Apart from these shared serotypes, the results have identified serotypes presently unique to each location, BLU3, 7, 9 and 12 in West Java and BLU16 in Irian Jaya. Despite serological evidence that BLU20 is widely distributed, so far there has been no confirmed isolation of this serotype in Indonesia.

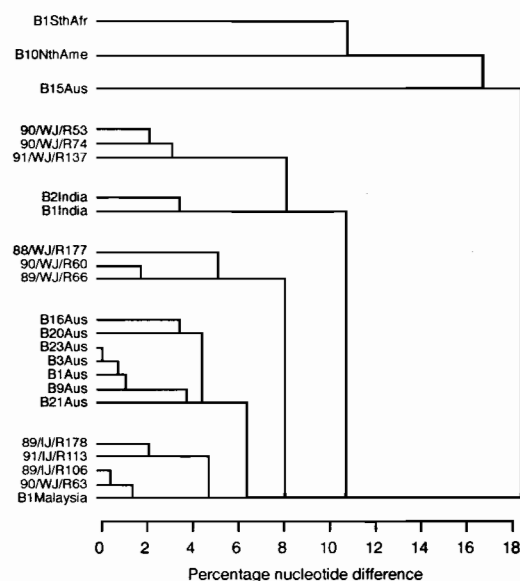

**Figure 1.** Dendrogram of genotypic relationships among Indonesian bluetongue virus (BLU) isolates.

Hence bluetongue viruses in Indonesia can be considered as three groups based on site of isolation (Table 1): those found only in the west, those found only in the east, and those found in both. A primary objective of the molecular studies was therefore to investigate whether these groupings were supported by sequence analysis of the RNA 3 gene segment. Also, since western and eastern Indonesia are adjacent to different land masses, the question arose as to whether the Indonesian viruses comprise one or more isolated populations, or whether they are shared in broader pools among different countries in close geographical proximity.

**Table 1.** Distribution of bluetongue virus (BLU) serotypes in Indonesia.

BLU serotype isolated	Provinces affected	
	West Java	Irian Jaya
BLU1	+	+
BLU3	+	
BLU7	+	
BLU9	+	
BLU12	+	
BLU16		+
BLU21	+	+
BLU23	+	+

## Materials and Methods

### Viruses and nucleic acids

Bluetongue virus isolates (Table 2) were grown in baby hamster kidney (BHK21) cells and nucleic acid was extracted as described by Eaton and Gould (1987). Complementary DNA (cDNA) copies of dsRNA were generated using AMV reverse transcriptase (Promega) as described previously (Pritchard et al. 1995), and BLU VP3 gene-specific primers as described by McColl and Gould (1991).

### Polymerase chain reaction and sequencing

Polymerase chain reaction (PCR) amplification from cDNA was done using the GeneAmp DNA reagent kit (Perkin-Elmer Cetus) following manufacturer's recommendations (Saiki et al. 1988) with minor modifications (McColl and Gould 1991). Procedures were carried out in a final volume of 50 mL for 25 cycles of denaturation, 94°C for 1 minute, annealing, 37°C for 2 minutes and elongation at 72°C for 2 minutes. An aliquot of 50 mL of each PCR was analysed in a 1.8% agarose/TAE buffer gel containing ethidium

bromide. After electrophoresis, the DNA fragments were visualised under ultraviolet light. Nucleotide sequencing of PCR products was done by the dideoxy-nucleotide chain termination method with Sequenase (USB, Amersham) using their PCR Sequencing Kit according to the instructions provided.

### Computer analysis of nucleotide and amino acid sequences

Nucleotide sequence alignments were done with the ALIGN Plus program Version 2.0 (Scientific & Educational Software): SEQPROG (Knowles, unpublished) was used to compare the sequences using DNADIST and KITSCH programs from the PHYLIP package (Felsenstein 1985) and to give a single most parsimonious, unrooted tree.

## Results and Discussion

Table 2 summarises data on the Indonesian BLU isolates included in this study, the collection sites, date of collection, and serotype. After isolation in cell culture, isolates were analysed by PCR and sequencing. Nucleotide sequence homology among these Indonesian BLU isolates using partial VP3 gene sequences was calculated: homologies varied between 88% and 100% identity depending on which isolates were compared (Table 3). Isolates were grouped on the basis of sequence homologies greater than 95%.

All the partial VP3 gene sequences of these Indonesian BLU isolates belonged to the Australasian toptotype or regional grouping, as distinct from the South African and North American groupings and the special group comprising the Australian BLU15 (Gould 1987; Pritchard et al. 1995). Within the Australasian toptotype, further groupings of these Indonesian isolates were observed, even from the same collection site. Three such groups were identified in which VP3 gene sequences differed by only 5% within each group, while there was an 11% difference between groups (Fig 1).

**Table 2.** Grouping of bluetongue virus (BLU) isolates in Indonesia, based on nucleotide sequence analysis.

Isolate	BLU serotype	Source	Date	Sequence group
RIVS 53	3	West Java	March 90	A
RIVS 74	9	West Java	January 90	A
RIVS177	9	West Java	March 88	B
RIVS 66	21	West Java	December 89	B
RIVS 60	21	West Java	April 90	B
RIVS 63	21	West Java	June 90	C
RIVS137	21	West Java (insect)	May 91	A
RIVS113	21	Irian Jaya	February 91	C
RIVS106	23	Irian Jaya	November 89	C
RIVS178	16	Irian Jaya	December 89	C



**Table 3.** Nucleotide sequence homology among the Indonesian bluetongue viral RNA 3 gene segments over the region 1398–1693bp.

	90/WJ/ R63	90/WJ/ R66	90/WJ/ R74	89/IJ/ R106	91/IJ/ R113	91/WJ/ R137	88/WJ/ R177	88/IJ/ R178	90/WJ/ R53	90/WJ/ R60
90/WJ/R63	.....									
89/WJ/R66	92	.....								
90/WJ/R74	90	87	.....							
89/IJ/R106	100	92	90	.....						
91/IJ/R113	96	93	89	96	.....					
91/WJ/R137	90	90	97	90	91	.....				
88/WJ/R177	93	96	89	92	92	91	.....			
88/IJ/R178	96	92	90	96	98	90	93	.....		
90/WJ/R53	89	88	98	89	90	98	89	90	.....	
90/WJ/R60	91	98	88	91	93	90	95	92	89	.....

In group A, isolate RIVS 137 was obtained from a mixed pool of *Culicoides (Avaritia)* species collected in May 1991 in West Java. The other isolates (RIVS 53 and 74) were from cattle blood collected in 1990. In this group, the sequence of the insect isolate did not differ significantly from those of the blood isolates. Group B comprised RIVS 60, 66, and 177 from West Java, isolated from cattle blood between 1988 and 1990. Group C consisted of three isolates from Irian Jaya (RIVS 106, 113, and 178) and one from West Java (RIVS 63). These Indonesian group C isolates were found to group with an isolate from Malaysia studied previously (Pritchard et al. 1995).

The groupings were independent of serotype (Table 2). Isolates of BLU21 were represented in each of groups A, B and C, and the two isolates of BLU9 from West Java occurred in groups A and B. Although the period of time represented by the isolates was too short to allow identification of significant temporal trends, both of the earlier (pre-1990) isolates in West Java (RIVS 177 and RIVS 66) were in group B, while the third group B isolate (RIVS 60) overlapped the group A isolates in 1990. The group C isolates spanned the period November 1989 (RIVS 106) to February 1991 (RIVS 21).

Hence, even within a short time period (1988–1991), a range of VP3 genome sequence-types were observed circulating within the islands of the Indonesian archipelago. While in West Java there were two circulating groups of viruses with similar VP3 genome sequences identified only at that location, another group (group C) contained BLU isolates from Irian Jaya, Malaysia and West Java (Fig. 1).

Since the molecular analyses indicated that the viruses in Irian Jaya were homologous with isolates from West Java and Malaysia, the possibility is raised of a common pool of isolates deriving from mainland Southeast Asia and spread throughout the island

chain. However this suggested picture was confounded by the simultaneous identification of a further two distinct groupings of bluetongue viruses in West Java. For these groups of isolates to be genetically distinct, we may hypothesise prolonged periods of separation of these groups, allowing divergent evolution. This would then imply that at least some of the three groups identified in West Java have been introduced from elsewhere, or that different groups of viruses can evolve separately in the same geographic area.

Routes of suspected vector and arboviral movements have been frequently hypothesised (Dyce 1982; St. George 1986; McColl et al. 1994). Molecular epidemiological studies of virus isolates have the capability to identify differences among isolates of the same virus from different geographic regions (Trent et al. 1983). Differences have been shown between Australasian, South African and North American BLU isolates based on gene sequences of the conserved core protein VP3 (Gould and Pritchard 1990; Pritchard et al. 1995), and hence inferences made on the geographic origin of isolates showing similar sequences (Gould 1987; Gould and Pritchard 1990; Pritchard et al. 1995).

None of these Indonesian isolates grouped with the prototype viruses from northern Australia, isolated during the period 1975 to 1986 (Gard and Melville 1989). Hence the Indonesian viruses seem to represent populations separate from the early Australian isolates, although since the rate of evolutionary change in sequence is unknown for these viruses, the effect of time on the variability of the genotypes of these viral populations cannot be assessed with confidence.

Much remains to be learned about the relationships among bluetongue viruses in the Australian and South-east Asian regions, especially in Indonesia where traffic in livestock, and so presumably in insect vectors, continues between the western and eastern regions.

## Acknowledgments

Ross Lunt and Kim Newberry grew and confirmed the serotypes of these viruses. The molecular studies were funded by Exotic Animal Disease Preparedness Consultative Council (EXANDIS).

## References

- Daniels, P.W., Sendow, I., Soleha, E., Sukarsih, Hunt, N.T. and Bahri, S. 1995. Australian-Indonesian collaboration in veterinary arbovirology. A review. *Veterinary Microbiology*, 46, 151-174.
- Dyce A.L. 1982. Distribution of *Culicoides* (Avaritia) spp. (Diptera: Ceratopogonidae) west of the Pacific Ocean. In: St. George, T.D. and Kay, B.H. ed., *Arbovirus research in Australia*. Proceedings 3rd Symposium. CSIRO/Queensland Institute of Medical Research, Brisbane 35-43.
- Eaton, B.T. and Gould, A.R. 1987. Isolation and characterization of orbivirus genotypic variants. *Virus Research*, 6, 363-382.
- Felsenstein, J. 1985. Confidence limits on phylogenies: an approach using the bootstrap. *Evolution*, 39, 783-791.
- Gard, G.P. and Melville, L.F. 1989. The evolution of bluetongue in Northern Australia. In: Uren, M.F., Blok, J. and Manderson, L.H. ed., *Arbovirus research in Australia*, Proceedings 5th Symposium. CSIRO/Queensland Institute of Medical Research, Brisbane 303-305.
- Gorman, B.M., Taylor, J. and Walker, P.J. 1983. *Orbiviruses*. In: Joklik, W.K., ed., *The Reoviridae*. Plenum Press, New York, ch. 7.
- Gould, A.R. 1987. The complete nucleotide sequence of bluetongue virus serotype 1 RNA3 and a comparison with other geographic serotypes from Australia, South Africa and United States of America, and with other orbivirus isolates. *Virus Research*, 7, 169-183.
- Gould, A.R., Hyatt, A.D., Eaton, B.T., White, J.R., Hooper, P.T., Blacksell, S.D. and Le Blanc Smith, P.M. 1989. Current techniques in rapid bluetongue virus diagnosis. *Australian Veterinary Journal*, 66, 450-454.
- Gould, A.R. and Pritchard, L.I. 1990. Relationships amongst bluetongue viruses revealed by comparisons of capsid and outer coat protein nucleotide sequences. *Virus Research*, 17, 31-52.
- 1991. Phylogenetic analyses of the complete nucleotide sequence of the capsid protein (VP3) of Australian epizootic haemorrhagic disease of deer virus (serotype 2) and cognate genes from other orbiviruses. *Virus Research*, 21, 1-18.
- Huisman, H. 1979. Protein synthesis in bluetongue virus-infected cells. *Virology*, 92, 385-396.
- McColl, K.A. and Gould, A.R. 1991. Detection and characterisation of bluetongue virus using the polymerase chain reaction. *Virus Research*, 21, 19-34.
- McColl, K.A., Gould, A.R., Pritchard, L.I., Melville, L. and Bellis, G. 1994. Phylogenetic characterisation of bluetongue viruses from naturally-infected insects, cattle and sheep in Australia. *Australian Veterinary Journal*, 71, 102-105.
- Mertens, P.P.C., Brown, F. and Sangar, D.V. 1984. Assignment of the genome segments of bluetongue virus type 1 to the proteins which they encode. *Virology* 135, 207-217.
- Miura, Y., Inaba, Y., Tsuda, T., Tokuhisa, S., Sato, K., Akashi, H. and Matumoto, M., 1982. A survey of antibodies to arthropod-borne viruses in Indonesian cattle. *Japanese Journal of Veterinary Science*, 44, 857-863.
- Pritchard, L.I., Gould, A.R., Wilson, W.C., Thompson, L., Mertens, P.P.C. and Wade-Evans, A.M. 1995. Complete nucleotide sequence of RNA segment 3 of bluetongue serotype 2 (Ona-A). Phylogenetic analyses reveal the probable origin and relationship with other orbiviruses. *Virus Research*, 35, 247-261.
- Saiki, R.K., Gelfand, D.H., Stoffel, S., Scharf, S.J., Higuchi, R., Horn, G.T., Mullis, K.B. and Erlich, H.A. 1988. Primer-directed enzymatic amplification of DNA with a thermostable DNA polymerase. *Science*, 239, 487-491.
- Sendow, I., Daniels, P.W., Cybinski, D.H., Young, P.L. and Ronohardjo, P. 1991a. Antibodies against certain bluetongue and epizootic haemorrhagic disease viral serotypes in ruminants. *Veterinary Microbiology*, 28, 111-118.
- Sendow, I., Daniels, P.W., Soleha, E., Erasmus, B., Sukarsih and Ronohardjo, P. 1993a. Isolation of bluetongue virus serotypes new to Indonesia from sentinel cattle in West Java. *Veterinary Record*, 133, 166-168.
- Sendow, I., Daniels, P.W., Soleha, E., Hunt, N. and Ronohardjo, P. 1991b. Isolation of bluetongue viral serotypes 7 and 9 from healthy sentinel cattle in West Java, Indonesia. *Australian Veterinary Journal*, 68, 405.
- Sendow, I., Soleha, E., Daniels, P.W., Sebayang, D., Achdiyati, J., Karma, K. and Erasmus, B.J. 1993b. Isolation of bluetongue virus serotypes 1, 21 and 23 from healthy cattle in Irian Jaya, Indonesia. *Australian Veterinary Journal*, 70, 229-230.
- Sendow, I., Sukarsih, Soleha, E., Erasmus, B.J. and Daniels, P.W. 1993c. Isolation of bluetongue virus serotype 21 from *Culicoides* spp. in Indonesia. *Veterinary Microbiology*, 36, 349-353.
- Sendow, I., Young, P. and Ronohardjo 1986. Serological studies of bluetongue virus in Indonesia. In: St. George, T.D., Kay, B.H. and Blok, J., ed., *Arbovirus research in Australia*. Proceedings 4th Symposium. CSIRO/Queensland Institute of Medical Research, Brisbane, 271-273.
- St. George, T.D. 1986. Arboviruses infecting livestock in the Australian region. In: St. George, T.D., Kay, B.H. and Blok, J. ed., *Arbovirus Research in Australia*. Proceedings 4th Symposium. CSIRO/Queensland Institute of Medical Research, Brisbane, 23-25.
- Trent, D.W., Grant, J.A., Rosen, L. and Monath, T.P. 1983. Genetic variation among Dengue 2 viruses of different geographic origin. *Virology*, 128, 271-284.
- Verwoerd, D.W., Louw, H. and Ollerman, R.A. 1970. Characterization of bluetongue virus ribonucleic acid. *Journal of Virology*, 5, 1-7.
- Verwoerd, D.W., Els, H.J., De Villers, E.M. and Huisman, H. 1972. Structure of the bluetongue virus capsid. *Journal of Virology*, 10, 783-794.
- Young, P.L., Hunt, N.T., Ibrahim, I., Sarosa, A., Darminto and Ronohardjo, P. 1985. Establishment of a national serum bank in Indonesia. In: Della-Porta, A.J. ed., *Veterinary viral diseases: their significance in South East Asia and the Western Pacific*. Academic Press, Orlando, 381-384.

# Molecular Epidemiology of Bluetongue Serotype 10 Virus from the Western United States

B.I. Osburn, C.C. de Mattos, C.A. de Mattos and N.J. MacLachlan\*

## Abstract

Bluetongue viruses (BLU) have segmented genomes which are capable of reassorting with other strains and serotypes. Previous studies have utilised monoclonal antibodies, oligonucleotide fingerprinting, electropherotyping and nucleic acid hybridisation to demonstrate genetic heterogeneity. In this study, BLU serotype 10 field isolates from 1980–81 and 1990 were compared to prototype BLU2, 10, 11, 13 and 17 and BLU10 vaccine virus by sequence analysis. The results indicated that there were two major phylogenetic groups of both gene segments 2 and 9. Furthermore, the more conserved gene segment 9 was found to reassort with all serotypes. Prototype BLU13 virus was found to have gene segment 9 that was more similar to gene segment 9 from the BLU10 modified live virus vaccine which was in use 12 years before the prototype BLU13 virus was isolated. This suggests prototype BLU13 from the United States is a reassortant virus with gene segment 9 derived from BLU10 vaccine virus.

BLUETONGUE is an arthropod-borne viral disease of ruminants. The viruses causing the disease belong to the genus *Orbivirus*. Four different serotypes of bluetongue virus (BLU10, 11, 13 and 17) have been observed in western United States (Stott et al. 1981). The presence of the viruses is limited by the distribution and habitat of the vector *Culicoides variipennis* var. *sonorensis* in western United States (Tabachnick 1991). As this species is adapted to human habitats, infections are seasonal, being most common in ruminants in late summer and autumn. Sheep, prong-horned antelope, desert bighorn sheep and white-tailed deer are most susceptible to clinical disease (Jessup 1985). Cattle are commonly infected but rarely show clinical signs (Anderson et al. 1985). The clinical expression of disease in sheep, antelope and deer is associated with viral-based vascular lesions that lead to local thromboses and infarcts of tissues in sheep and disseminated intravascular coagulopathy in the free-ranging ruminants. In cattle, the clinical expression of disease is associated with an IgE-mediated

hypersensitivity (Anderson et al. 1985). Congenital BLU infection in sheep and cattle may result in hydranencephaly or porencephaly in sheep and cattle and retinal dysplasia in lambs (Osburn et al. 1971; MacLachlan and Osburn 1983).

Evidence of strain differences in virulence and pathogenic characteristics of viruses of BLU serotypes became apparent during surveillance surveys for prevalence of infection in ruminants. BLU was occasionally isolated from sheep flocks that had no evidence of clinical disease (Stott et al. 1985). Electropherotyping of BLU isolates indicated that there was considerable variation in genome migration patterns within and between serotypes (De Mattos et al. 1991). Further, studies with plaque-picked BLU11 isolates with different electropherotypic patterns, designated UC2 and UC8, indicated a difference in virulence and pathogenic properties of these viruses in newborn Balb/c mice and foetal calves (Waldvogel et al. 1987, 1992). The potential for genetic polymorphism in the BLU serogroups seemed apparent.

Genetic polymorphism is associated with differences in antigenic properties, vector susceptibility, tissue tropism and virulence exhibited by individual members of the same virus group or serotype. Even viruses isolated at the same time and from a common geographical region may be genetically heteroge-

---

\* Department of Pathology, Microbiology and Immunology, School of Veterinary Medicine, University of California, Davis, California 95616, USA.

nous, as may RNA viruses isolated from a single outbreak of disease or even from a single infected host (Sobrino et al. 1986). The natural replication cycle of bluetongue viruses, which includes insect vectors and various ruminant and carnivore hosts, offers significant opportunity for the generation or selection of genetically novel viruses (Roy 1988; Samal et al. 1987; Squire et al. 1983). The evolution and genetic variation of BLU in a restricted geographic region was studied by sequencing and phylogenetic analyses of the most variable gene segment (gene segment 2), and of one of the more conserved genome segments (gene segment 9) of field isolates of BLU10 and 17 obtained from the San Joaquin Valley of California in 1980, 1981 and 1990.

## Materials and Methods

### Viruses

This study involved BLU10 isolated from ruminants in different locations in California between 1980–1981 and 1990; prototype viral strains of the four serotypes in western USA; and a BLU10 virus vaccine strain (Table 1). The viruses were initially isolated in embryonated chicken eggs and propagated in BHK21 cells (Heidner et al. 1991). Viral dsRNA was extracted with phenol, precipitated with ethanol, and purified with lithium chloride (De Mattos et al. 1989).

### PCR amplification and cycling sequencing

The positive and negative strands of gene segments 2 and 9 of the viruses were reverse transcribed and amplified as previously described by Akita et al.

(1992) using different combinations of primers; BLU10 L-2 and BLU10 S-3. Primers were constructed from the published sequence of gene segments 2 and 9 of prototype strains of BLU10, 11, 13 and 17 (Ghiashi et al. 1987; Purdy et al. 1985; Fukusho et al. 1989). The cDNA was purified and sequenced by cycle sequencing using a commercial kit (f-mol DNA Sequencing System, Promega) as described by De Mattos et al. (1994a). Each sequencing reaction was repeated several times with PCR products from several different amplifications to control artefacts, and using different combinations of primers to obtain overlapping PCR products that together represented the entire nucleotide sequence of gene segments 2 and 9 of each virus. The Wisconsin Package was used to analyse the nucleotide sequences and to predict the amino acid composition of the putative proteins (Anon. 1991). Phylogenetic analysis was accomplished using the DNADIST and FITCH programs of the PHYLIP package Version 3.4 (Felsenstein 1991). Gene segment 2 of EHD-1 was used as an outgroup as previously described (De Mattos et al. 1994b). The nucleotide sequence corresponding to the 5' and 3' primers used to amplify the genes were not included in the phylogenetic studies. Bootstrap analysis of 100 replicates was performed as described by De Mattos et al. (1994b). A value greater than 95% was considered significant.

## Results

Gene segment 2 of all BLU10 isolates comprised 2926 base pairs indicating no insertions or deletions over a 37-year period. The genes coded for 956 amino acids. Gene segment 2 of the prototype strain, the

Table 1. BLU isolates from the United States of America.

Serotype	Field isolate or prototype	Species of origin	Year of isolation	County of isolation	State
BLU10	10080V	Ovine	1980	Tehama	California
	10B80Y	Bovine	1980	Tulare	California
	10080Z	Ovine	1980	Solano	California
	10090H	Ovine	1990	Mendocino	California
	10B90Z	Bovine	1990	Imperial	California
	10090Z	Ovine	1990	Chino	California
	Vaccine 10	Ovine	1953		California
	Prototype 10	Ovine	1953		California
BLU13	Prototype 13		1967		Idaho
BLU11	Prototype 11		1955		Texas
BLU17	Prototype 17	Bovine	1962		Wyoming
BLU2	Prototype 2		1983		Florida

modified live virus vaccine strain derived from the prototype virus and the 1980 field isolates differed only by 0.1–0.5%. In contrast, the 1990 field isolates constituted a separate group with similarities of 98.2–99.7% between each other, but a 4.8% divergence from the previously described BLU10 viruses. The vaccine strain had nine mutations when compared to the prototype virus, five of which (bases 497, 954, 998, 1012 and 1415) were unique to VAC 10. Four of the mutations (bases 76, 836, 1056 and 1754) were shared with all the field isolates. There were only five exclusive mutations (bases 690, 1836, 2161, 2212 and 2851) among the three 1980 isolates and the prototype virus isolated 37 years earlier. In contrast, the 1990 isolates had 102 nucleotide changes as compared to the prototype virus. These results indicate two distinct consensus sequences of BLU10 viruses in California over the last 37 years. Despite differences in nucleotide and amino acid sequences among these viruses from 1953 to 1990, the general characteristics of the hydrophobic profiles and secondary structure of their VP2 proteins remained similar.

Phylogenetic analyses of gene segment 2 of BLU prototypes and BLU10 field isolates (Fig. 1) indicated two distinct monophyletic groups, one including BLU2 and BLU13 and the other including BLU10, 11 and 17 and the field isolates from California. The monophyletic grouping of BLU10, 11 and 17 was supported by common deletions present in the nucleotide sequences of gene segments 2. Additional deletions are present between prototype strains of BLU10 and 11, and between positions 1827–1828 and 1916–1917 of prototype BLU17. The common deletions of the gene segment 2 of BLU10, 11 and 17 suggest that these deletions occurred in a common ancestor before the divergence of each serotype.

The Californian BLU10 viruses under study are derived from a common ancestor from which two different lineages diverged resulting in two monophyletic groups. One group consisted of the prototype, vaccine and 1980 field isolates, and the other the 1990 field isolates. The prototype, VAC 10 and 1980 viruses formed two sister groups. The 1990 group of three included strain 10090H which appeared to diverge earlier and followed a different evolutionary pathway. Isolates 10090Z and 10B90Z shared the same immediate ancestor. The varied differences in sequences suggest that the viruses were derived from different evolutionary pathways within the lineage.

Phylogenetic analyses of gene segment 9 of BLU10 isolates and prototype viruses (Fig. 2) indicated that BLU10 field isolates belong to two lineages, one consisting of BLU13, VAC 10, BLU10 and the 1980 field isolates, and the other lineage consisting of the 1990 field isolates, BLU11 and BLU17 prototype viruses. The bootstrap values of each node

were 79% and 80% respectively, which does not support the topology of the phylogenetic tree. This indicates that genome segment 9 from the viruses under study could not be separated in serotypes with a 95% level of confidence.

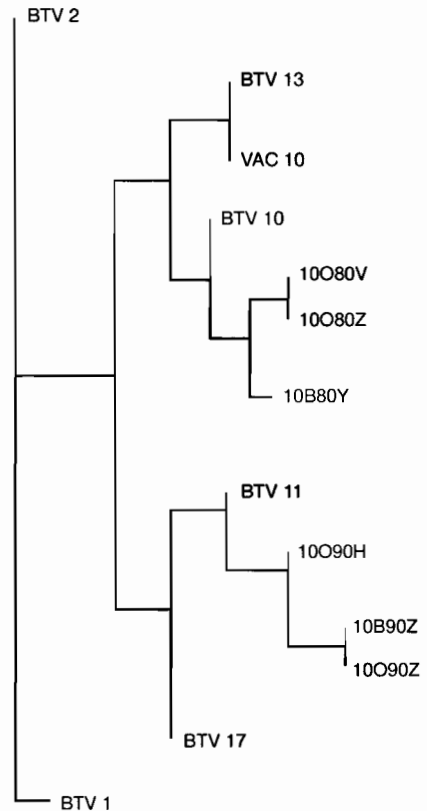

**Figure 1.** Phylogenetic tree of genome segment 2 of six BLU10 isolates, five USA BLU prototype strains and MLV VAC 10 (EHD1 used as an outgroup).

The prototype BLU13 genome segment 9 was highly homologous to the BLU10 (99.51%), VAC 10 (99.62%) and two of the 1980 field isolates (99.43% and 99.29%). The S3 gene of the 1990 field isolates was more closely related to BLU11 (between 98.5 and 98.4%) than to BLU10 (between 97.3 and 97.4%). Field isolates 10090Z and 10B90Z were identical, but the field isolate 10090H was only 97.93% related to the others. The deduced VP6 of BLU13 differs in only two amino acids (position 41 and 199) from the VP6 of VAC 10. These two S3 genes share a methionine codon at position 5, not present in the others, and they lack the third in-frame ATG initiation codon present in all other serotype 10 strains.

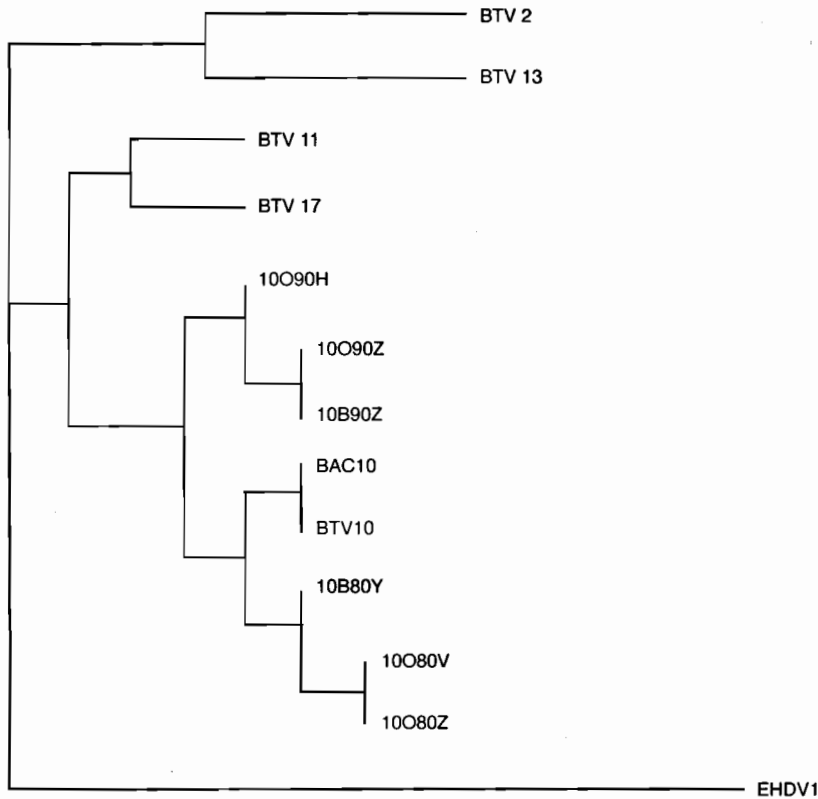

**Figure 2.** Phylogenetic tree of genome segment 9 genes of six BLU10 isolates, five USA BLU prototype strains and MLV VAC 10.

## Discussion

Genetic variability is a common characteristic of many RNA viruses. This genomic heterogeneity may form complex quasispecies populations that influence mammalian and vector preferences, viral ecology, virulence, pathogenesis and antigenic drift. In this paper we have attempted to begin identifying genomic variability and to associate it with phenotypic expression of the viruses, by comparing the variable gene segment 2 and more conserved gene segment 3 of U.S. prototype BLU viruses, and BLU10 field isolates.

The genomic analyses of the gene segment 2 of the viruses examined showed there were two major monophyletic groups of BLU in the USA, comprising BLU2 and 13, and BLU10, 11 and 17. In the case of BLU10, two distinct groups of viruses were observed. The first group is formed by BLU10 prototype strains, the 1980 field isolates and the vaccine strain (VAC 10, derived from the first isolate of BLU

obtained in 1953; Jessup 1985). The 1980 field isolates presented only 0.1–0.5% of divergence from the prototype and vaccine viruses. The second group is constituted by the 1990 field isolates. These viruses differed from the BLU10 prototype 10, VAC 10 and 1980 isolates by 4.8%. Although BLU10 isolates from California had a common ancestry, the 1953 and 1980 viruses were sufficiently distinct from the 1990 isolates to indicate that there had been at least two monophyletic BLU10 lineages present in California over the last 37 years. Furthermore, there was no proof that the VAC 10 vaccine virus had influenced the evolution of gene segment 2 of the 1990 viruses. No BLU10 isolates had been made before 1990 in southern California, unlike some of the 1990 isolates. These viruses were of a different lineage from those observed in California before 1990.

Gene segment 9 from the 1980 BLU10 field isolates formed a group that differed in their nucleotide sequences by only 0.08–0.38% from the BLU10 prototype and VAC 10. This contrasted with the 1990

field isolates which were more closely related to BLU11 (98.5% and 98.4%) than to BLU10 (97.3% and 97.4%). The data suggest that genome segment 9 of BLU10 isolates from California is derived from two different ancestors, probably evolving in different geographical areas. Also of interest was the finding that gene segment 9 of BLU13 prototype was highly homologous to VAC 10 (BLU10), suggesting that reassortant genes were present in these virus isolates. The appearance of the VAC 10 gene segment 9 with a methionine marker in the BLU13 prototype virus strongly suggests that the genes from VAC 10 virus and a BLU13 field isolate virus reassorted in a biological system before the initial isolation of BLU13 prototype virus in 1962. A precursor to the VAC 10 vaccine (Blucine, an embryonated egg adapted vaccine) was widely used from 1955 to 1970 in western United States. It is very likely that a BLU13 virus reassorted with the 'Blucine' vaccine virus, and the Blucine gene segment 9 was incorporated into the BLU13 virus, now considered the prototype virus.

Although BLU viruses are closely related, the segment 2 gene of each bluetongue virus was found to be distinct and their mutations have not followed a linear pattern of accumulation over time. This indicates that genome segment 2 of individual viruses might evolve via different evolutionary pathways. These studies further demonstrate that the gene segment 2 population of BLU field isolates are formed by nonidentical but closely related genomes as occurs with the genomes of other RNA viruses.

The phylogenetic analyses of the S3 gene of BLU10 field isolates demonstrated that, despite the conserved nature of this gene, genetic variants are present in the natural BLU population. The clear separation in serotype was not supported by the statistical analyses of their phylogeny. This suggests that the S3 population may be formed by a spectrum of viral variants closely related to a consensus sequence that evolved to its maximum fitness for the virus replication in nature. The stability of this consensus sequence in nature is facilitated by reassortment events that assure the efficient distribution of the most fitted variants among serotypes.

In arbovirus ecology, the vector, host and environment are in a dynamic equilibrium with the temporary or long-term predominance of the viral consensus sequence best suited to the prevalent conditions. Any change in the biological environment that disrupts this equilibrium allows different viral variants to become dominant.

## References

- Akita, G.Y., Chinsangaram, J., Osburn, B.I., Ianconescu, M. and Kaufman, R. 1992. Detection of bluetongue virus serogroup by polymerase chain reaction. *Journal of Veterinary Diagnostic Investigations*, 4, 400-405.
- Anderson, G.A., Stott, J.L., Gershwin, L.J. and Osburn, B.I. 1985. Subclinical and clinical bluetongue disease in cattle: clinical, pathological and pathogenic considerations. In: Barber, T.C., Jochim, M.S. and Osburn, B.I. ed., *Bluetongue and related orbiviruses*. Progress in Clinical and Biological Research, vol. 178, Alan R. Liss Inc., New York, 178, 53-65.
- Anon. 1991. Program Manual for the GCG Package, Version 7. 575 Science Drive, Madison, Wisconsin 53711, USA.
- De Mattos, C.A., De Mattos, C.C., Osburn, B.I. and MacLachlan, N.J. 1994a. Heterogeneity of L2 gene of field isolates of bluetongue virus serotype 17 from San Joaquin Valley of California. *Virus Research*, 31, 67-87.
- De Mattos, C.C., De Mattos, C.A., Osburn, B.I., Dangler, C.A., Doi, R. and Chuang, R.Y. 1989. Recombinant DNA probe for serotype specific identification of BLU17. *American Journal of Veterinary Research*, 50, 536-541.
- De Mattos, C.C., De Mattos, C.A., Osburn, B.I., Ianconescu, M. and Kaufman, R. 1991. Evidence of genome segment 5 reassortment in bluetongue virus isolates. *American Journal of Veterinary Research*, 52, 1794-1798.
- 1994b. Evolution of the L2 gene of strains of bluetongue virus serotype 10 isolated in California. *Virology*, 201, 173-177.
- Felsenstein, J. 1991. PHYLIP (Phylogenetic Inference Package) 3.4 Manual. Department of Genetics SK-50, University of Washington, Seattle, Washington 98195, USA.
- Fukusho, A., Yu, Y., Yamaguchi, Y. and Roy, P. 1989. Completion of the sequence of bluetongue virus serotype 10 by the characterization of structural protein VP6 and non-structural protein NS2. *Journal of General Virology*, 70, 1677-1689.
- Ghiashi, H., Fukuso, A., Eshita, Y. and Roy, P. 1987. Identification of conserved and variable regions in the neutralization VP2 gene of bluetongue virus. *Virology*, 160, 100-109.
- Heidner, H.W., Iezzi, L.G., Osburn, B.I. and MacLachlan, N.J. 1991. Genetic variation and evolutionary relationships amongst bluetongue viruses endemic in the United States. *Virus Research*, 21, 91-109.
- Jessup, D.A. 1985. Epidemiology of two orbiviruses in California's native wild ruminants: Preliminary report. In: Barber, T.C., Jochim, M.S. and Osburn, B.I. ed., *Bluetongue and Related Orbiviruses*. Progress in Clinical and Biological Research, vol. 178, Alan R. Liss Inc., New York, 53-65.
- MacLachlan, N.J. and Osburn, B.I. 1983. Bluetongue virus-induced hyranencephalopathies in cattle. *Veterinary Pathology*, 20, 563-573.
- Osburn, B.I., Johnson, R.T., Silverstein, A.M., Prendergast, R.A., Jochim, M.M. and Levy, S.E. 1971. Experimental viral-induced congenital encephalopathies. II. The pathogenesis of bluetongue vaccine virus infection in foetal lambs. *Laboratory Investigations*, 25, 206-210.
- Purdy, M.A., Ghiashi, H., Rao, C.D. and Roy, P. 1985. Complete sequence of bluetongue virus L2 RNA that codes for the antigen recognized by neutralizing antibodies. *Journal of Virology*, 67, 957-962.

- Roy, P. 1988. Bluetongue virus genetics and genome structure. *Virus Research*, 13, 179–206.
- Samal, S.K., Livingstone, C.W., Jr., McCowel, S. et al. 1987. Analysis of mixed infection of sheep with bluetongue virus serotypes 10 and 17: evidence for genetic reassortment in the vertebrate host. *Journal of Virology*, 61, 1086–1091.
- Sobrino, F., Palma, E.L., Bech, E., Davila, M., de la Torre, J.C., Negro, P., Villanueva, N., Ortin, J. and Domingo, E. 1986. Fixation of mutations in the viral genome during an outbreak of foot and mouth disease: heterogeneity and rate of variation. *Gene*, 50, 149–159.
- Squire, K.E., Osburn, B.I., Chuang, R.Y. and Doi, R.H. 1983. A survey of electropherotype relationships of bluetongue virus isolates from western United States. *Journal of General Virology*, 64, 2103–2115.
- Stott, J.L., Else, K.C., McGowan, B., Wilson, L.K. and Osburn, B.I. 1981. Epizootiology of bluetongue virus in western United States. In: United States Animal Health Association, Proceedings 85th Annual Meeting. United States Animal Health Association, St. Louis, Missouri, 170–180.
- Stott, J.L., Osburn, B.I., Bushnell, R., Loomis, E.C. and Squire, K.E. 1985. Epizootiological study of bluetongue virus infection in California livestock: an overview. In: Barber, T.C., Jochim, M.S. and Osburn, B.I. ed., *Bluetongue and Related Orbiviruses*. Progress in Clinical and Biological Research, vol. 178, Alan R. Liss Inc., New York, 571–582.
- Tabachnick, W.J. 1991. Genetics, population genetics, and evolution of *Culicoides variipennis*: implications for bluetongue virus transmission in the USA and its international impact. In: Walton, T.E. and Osburn, B.I., ed., *Bluetongue, African horse sickness and related orbiviruses*. Proceedings 2nd International Symposium. CRC Press, Boca Raton, 262–270.
- Waldvogel, A.W., Anderson G.A., Higgins, R.J. and Osburn, B.I. 1987. Neurovirulence of UC-2 and UC-8 strains of bluetongue virus serotype 11 in newborn mice. *Veterinary Pathology*, 24, 404–410.
- Waldvogel, A.W., Anderson, G.A., Phillips, D.L. and Osburn, B.I. 1992. Association of virulent and avirulent strains of bluetongue virus serotype 11 with premature births of late-term bovine fetuses. *Journal of Comparative Pathology*, 106, 333–340.



# Control of Bluetongue Disease with Attenuated Vaccine

**Shun Yourong, Zhang Yuchun, Hu Zhiyou, Yuan Yudong,  
Wu Zhuoshou and Liu Gongchen\***

## *Abstract*

In 1987, an outbreak of bluetongue occurred in sheep on a farm in Wuxi country, Sichuan Province. Of the 472 sheep, 143 (30.3%) exhibited disease and 93 (65%) of these died. Bluetongue antibodies were found in animals and bluetongue virus (BLU) was isolated at the Yunnan Tropical and Subtropical Animal Virus Disease Laboratory from blood and tissue samples. From 1989 to 1994, a combined attenuated virus vaccine (serotypes BLU1 and 16) prepared at that laboratory was used to control bluetongue disease. Over six years 36,523 sheep were vaccinated. Of those vaccinated only with BLU16 vaccine, 98/3184 (3%) were susceptible to naturally acquired bluetongue in contrast to 67/148 (45.7%) of unvaccinated controls. Seven sheep developed bluetongue in 1989, but none did so in 1990, 1992 and 1994.

---

\* Wanyan City Animal Quarantine Station, Wanyan City  
634000, Sichuan, People's Republic of China.

# Using Inactivated Vaccine to Prevent Bluetongue in Hubei Province, China

Zhou Yong\*, Cao Zhenghui\*, Cheng Yuankun\*, Li Zhihua†, Peng Kegao†, Zhang Khaili†, Duan Jinrong§, Zhang Xuezhi§, Wang Fucui¶ and Wu Jianzhang¶

## Abstract

In 1989 an outbreak of bluetongue on a sheep farm in Xiangfan, Hubei Province, caused serious economic loss: 1505 (81%) of the 1837 sheep showed disease, and 521 (34%) of these died. From 1990 to 1994, agar gel immunodiffusion (AGID) was used to distinguish seropositive sheep from seronegatives. The seropositive sheep were eliminated. As a preventative measure, the seronegative sheep were immunised with an inactivated vaccine made at the Yunnan Tropical and Subtropical Animal Virus Diseases Laboratory. This vaccine successfully reduced losses.

USING inactivated vaccine to prevent bluetongue in Hubei, one of China's epidemic bluetongue areas, has been justified as an effective strategy by economic data from 1990-1994 and epidemiological survey results.

In 1989 an outbreak of bluetongue on a sheep farm in Xiangfan, Hubei Province, caused serious economic loss: 1505 (81%) of the 1837 sheep showed disease, and 521 (34%) of these died. From 1990 to 1994, agar gel immunodiffusion (AGID) was used to distinguish seropositive sheep from seronegatives. The seropositive sheep were eliminated. As a preventative measure, the seronegative sheep were immunised with an inactivated vaccine made at the Yunnan Tropical and Subtropical Animal Virus Diseases Laboratory.

The economic loss because of sheep mortality was RMB 86850 (in 1995, 1 Chinese Renminbi (RMB)

was equivalent to US\$0.123), the cost of medication was RMB 23000, and the loss of breeding animals (982 sheep infected with bluetongue) was valued at RMB 140000.

Since inactivated vaccination was first applied in 1991, the situation has changed substantially. Proven effective by a provisional experiment in 1990, vaccination has been carried out extensively on the Xiangfan breeding farm since 1991. Of the total 3195 sheep immunised with inactivated vaccine up until 1994, only 18 animals (0.6%) have been found infected by bluetongue virus (BLU), and none were found in 1992 and 1994. Morbidity has declined. Over the four-year period, bluetongue disease occurred in only 18/2939 (0.6%) and no sheep died. In 1991, morbidity was 11/1012 (1.1%) with no deaths. In 1992, 609 sheep were vaccinated and there was no bluetongue on the farm that year. In 1993, morbidity was 7/546 (1.3%) with no deaths, compared to 178 (39.3%) of 452 unvaccinated controls that developed bluetongue, 31 (17.4%) of which died. In 1994 804 sheep were vaccinated and there was no bluetongue on the farm that year. The AGID positive rate has also declined, from 81% in 1989 to 13.9% (505/3624) from 1991 to 1994. These results demonstrate that bluetongue has been effectively controlled.

Together with inactivated vaccine, other comprehensive controls were used, including serological monitoring by AGID testing; strict quarantine when

\* Hubei Provincial Animal Disease Prevention Station, Wuhan 23001, People's Republic of China.

† Yunnan Tropical and Subtropical Animal Virus Diseases Laboratory, Jindian 650224, Kunming, People's Republic of China.

§ Xiangfan Animal Disease Prevention Station, Xiangfan, Hubei, People's Republic of China.

¶ Xiangfan Domestic Animal Farm, Xiangfan, Hubei, People's Republic of China.

introducing breeding sheep; and eliminating vector insects such as *Culicoides*.

As a result of the vaccination program and other measures, from 1991 to 1994 economic losses decreased significantly: 2459 breeding sheep did not have to be rejected for being seropositive (value RMB 491800), 521 sheep were saved by vaccination (value RMB 156300) and there was a saving in the

cost of medication that would have been needed for bluetongue therapy (RMB 183000). This gives an estimate of RMB 831100 saved through the vaccination program.

In summary, the inactivated bluetongue vaccine was extremely effective on the Xiangfan breeding farm, as reflected both in epidemiological and economic analysis.

# Development of Bluetongue Attenuated Vaccine in China

Zhang Nianzu, Li Zhihua, Zhang Khaili, Hu Yuling, Li Gen,  
Peng Kegao, Zhou Fuzhong, Li Huachun, Zhao Kuen and Liu Gui\*

## Abstract

Previous studies elsewhere have shown that an attenuated vaccine for bluetongue, produced through passages in embryonated chick embryos (ECE), could protect sheep successfully. In China, we have also developed this kind of vaccine, using virulent strains of bluetongue virus isolated from clinically ill sheep in Yunnan and Sichuan Provinces and that differ from one another in neutralisation tests. These viruses were passaged in sheep two to three times and remained virulent. Blood from these sheep were serially passaged through ECE to produce the crude vaccines. There were some differences in the development procedures used to make vaccines from the Yunnan and Sichuan strains. In an immunisation experiment with the Sichuan strain, sheep were divided into two groups, with an additional control group. One group was immunised with Sichuan ECE vaccine. Another group was immunised first with the Yunnan ECE-vaccine and then with the Sichuan ECE vaccine. Both groups were then challenged with the highly virulent Sichuan strain. From this experiment, we confirmed the attenuation of the virulence of the Yunnan and Sichuan strains by the ECE passages, although some subclinical symptoms (such as elevated temperature and changes in white blood cells) occurred in a few sheep. In these immunisation experiments, the ECE vaccines were shown to be effective, with greatest effectiveness after 47 passages ( $ID_{50}=10^{3.6}$ ) and reduced effectiveness after 60 passages. From 14 to 21 days after vaccination, 90% of sheep could be protected when challenged by highly virulent strains.

SINCE the beginning of this century, the development and production of bluetongue vaccines has been studied, first in South Africa and later in the USA. The earliest vaccination involved inoculating blood, containing virulent virus, from a sick sheep, plus the serum of recovered sheep. In South Africa, Spruell (1906) followed the procedure for producing attenuated *Theileria* vaccine by passaging in sheep ten times (Theiler 1908). This method was used effectively for more than 40 years (Neitz 1948). However, chick embryo vaccine was substituted when Alexander et al. (1947) showed that virulent BLU could be attenuated via passaging in embryonated chick embryos (ECE) when inoculated through either vein or amnion and incubated at 33.5–34°C. A multivalent

vaccine was subsequently developed by Alexander and Haig (1951). In the USA, McKercher et al. (1957) developed an ECE-attenuated vaccine using local isolates. Later research indicated that ECE vaccine did not return to virulence after several passages in sheep, and sheep inoculated with virulent BLU were not susceptible six weeks after vaccination with ECE-attenuated vaccine, with a protection rate of 92% (McGowan et al. 1956). Transmission via *Culicoides* was always a possibility (Foster et al. 1968). Other BLU vaccines have been developed since then via tissue culture of ECE-adapted virus (Kemeny and Drehle 1961). Commercial vaccine for bluetongue is now available in South Africa and USA.

In 1979, the economic loss attributable to bluetongue outbreaks in ruminants in China was significant because of the lack of a vaccine (Zhang Nianzu et al. 1989). The work on developing vaccines and vaccination procedures commenced in 1980. This paper reports development of an ECE-attenuated vac-

---

\* Yunnan Tropical and Subtropical Animal Virus Diseases Laboratory, Jindian 650224, Kunming, People's Republic of China.

cine in the epidemic areas of the Provinces of Yunnan (begun in 1980) and Sichuan (begun in 1988). Two isolates from these areas were identified as significant serotypes in China.

## Materials and Methods

### Original isolates as inocula

Yunnan inocula Y33-F2-89, Y55-F3-447 and Y55-F3-471 were passaged two to three times after isolation from naturally infected sheep no. 33 (Y33) and no. 55 (Y55). The storage period of all inocula was less than 30 days.

Sichuan inoculum SW-0.926 (isolated from naturally infected sheep blood; Lin Lihui et al. 1989) was passaged in sheep two to three times, frozen and thawed three times at  $-80^{\circ}\text{C}$ , then lysed by ultrasonication, just before use.

Eleven-day-old ECE were inoculated intravenously by the methods of Goldsmit and Barzaili (1968) and Foster and Luedke (1968), and amnion inoculated using seven- to eight-day-old ECE. The eggs were provided by a specific pathogen-free breeding farm. The amounts for inoculation were as follows: 0.2 mL were used for amnion or inoculation and 0.02 mL for vein; five eggs per inoculum; 5–15 eggs per passage. These were incubated at  $35^{\circ}\text{C}$  for 7 days, and discarded if ECE died within 24 hours. Dead embryos were stored at  $4^{\circ}\text{C}$ , while all live embryos were chilled at  $4^{\circ}\text{C}$ . At harvest, a 1:5 homogenate of the ECE muscle and liver was made in saline (pH7.2), containing 100 IU penicillin and streptomycin per mL. The product was frozen and thawed twice, then stored at  $4^{\circ}\text{C}$  for 48 hours before use. Five to fifteen ECE were used per inoculum at each passage level, using the above procedure. Batches with less than 50% mortality in the previous three to five passage were repeated.

The virulence was measured by following the protocol of Zhang Khaili et al. (1991). Sheep were inoculated with 5–10 mL homogenate of ECE Y33-89F4, 6, 8, 25, 47 and 108; and Y55-471F13 and 22; Y55-471F46 and 53 in Yunnan, and F26, 30 and 35 in

Sichuan. Immunofluorescence of ECE organs, including heart, liver, brain, amnion and its fluid and the body (Y33-89F52; Y55-447F57, 65, 74 and 75; and Y55-471F46, 53), was tested on frozen sections (Hu Yuling et al. 1989). AGID tests were performed by standard protocols (Anon. 1989).

Two sheep per specimen were inoculated, with 4 mL per sheep of the ECE homogenate proved to be attenuated, including Y33-89F51 and F115 (Yunnan). Blood was collected seven days post-infection, the serum discarded and the red cells resuspended in saline, then blind passaged in sheep four times. The sheep were observed for clinical signs. The original experimental sheep were challenged at 14–21 days post infection with 100  $\text{IC}_{50}$  of virulent virus. The  $\text{LD}_{50}$  of per passage of homogenate of ECE was calculated.

### Vaccination experiment

The vaccination and challenge experimental procedure is summarised in Tables 1 and 2. All sheep were Xinjiang Merinos which tested negative for bluetongue antibodies before vaccination (Hu Yuling 1991). Two or three healthy sheep were used as controls. Body temperature and clinical signs were recorded daily. Leucocyte numbers were counted every two days.

Healthy sheep were inoculated with one of several dilutions of the attenuated inocula from ECE of Y33-89F47, 88, 51 and 59. Challenge was with one of the virulent blood inocula of Y33F3-778 and 505 and Y33F16-459 at 14, 21 and 35 days post-infection respectively. The body temperature, leucocyte numbers and clinical signs were compared with the control group to calculate the vaccination efficiency.

Three sheep were vaccinated with 5 mL of Y55-471F36 ECE homogenate, and blood was collected at 5, 8, 14, 30, 90 and 120 days post-infection. The virus was separated from the blood sample (following the protocol of Zhang Khaili et al. 1991) and the ECE inoculated into the amnion: these were then blind passaged five times. A positive result was indicated when 50% of ECE died in three successive passages within five days of inoculation.

**Table 1.** Vaccination procedure for bluetongue in Yunnan Province.

Vaccination inoculum (from ECE)	No. of sheep	Volume of inoculum (mL)	Challenge (days post-infection)	Challenge inoculum (from blood)	Volume and dose of challenge
Y33-89F46	2	5	35	Y33F-459 or Y33F3-505	0.5 mL (50 $\text{ID}_{50}$ )
Y33-89F47	3	5	35	Y33F-459 or Y33F3-505	0.5 mL (50 $\text{ID}_{50}$ )
Y33-89F75	3	5	35	Y33F-459 or Y33F3-505	0.5 mL (50 $\text{ID}_{50}$ )
Y33-89F108	3	5	35	Y33F-459 or Y33F3-505	0.5 mL (50 $\text{ID}_{50}$ )
Y55-471F46	3	5	35	Y55-F5-598	3 mL (300 $\text{ID}_{50}$ )

**Table 2.** Vaccination procedure for bluetongue in Sichuan Province.

Trial	No. of sheep	Basic inoculum		Second inoculation (42 days post-infection)			Challenge	
		Inoculum (ECE)	Volume and dose	Inoculum (ECE)	Volume and dose	Days post-inoculation	Inoculum (blood)	Volume and dose
1	5	SWF38	2 mL, 1:50	—	—	21	Sichuan virulent	0.5 mL 100 LD <sub>50</sub>
2	1	Yunnan attenuated vaccine	5 mL, 1:10	SWF22	5 mL, 1:50	14	virulent specimen	0.5 mL, 100 LD <sub>50</sub>
	1	"	1:50	Treatment for other dosages at 1:10				
	1	"	1:100					
	1	"	1:1000					
	1	"	1:1500					

## Results

### Development of ECE attenuated vaccine

The results of the inoculation and passaging of virulent blood specimen to ECE are shown in Table 3.

ECE death, with swollen and haemorrhagic embryos, occurred regularly after 5–8 passages. Passaging was continued to a maximum of 113 times. The pathogenicity of BLU was attenuated after 46 passages in ECE although it could cause some clinical signs at 5–25 passage when tested in sheep (Table 4).

**Table 3.** Inoculation and passage in ECE for development of bluetongue vaccine.

Inoculum	Route	Passage no.	Duration of passage (days)	Cycle of passage (average days per passage)	Passage number for recovery of virulence
Y33-89 I	amnion	103	584	5.1	117
Y33-89 II	1–7 passage with vein then to amnion	113	679	5.1	114
Y55-471	amnion	45	427	9.26	89

**Table 4.** Pathogenicity test of bluetongue virus attenuated via ECE passage.

Inoculum	Dilution of inoculum	Inoculum mL	No. of sheep	Observation (symptoms)		Pathogenicity ratio
				Subclinical	Clinical	
Y55-447F13	—	5	3	1	1	1:3
Y55-447F22	—	5	3	1	1	1:3
Y55-471F23	—	5	3	1	1	1:3
Y55-472F46	—	5	3	0	0	0:3
Y33-89F5	—	10	2	2	0	2:2
Y33-89F6	—	10	3	3	0	3:3
Y33-89F7	—	10	2	2	0	2:2
Y33-09F25	—	10	3	3	3	3:3
	1:5	10	3	0	1	1:3
	1:10	10	3	3	3	3:3
	1:20	10	3	0	0	0:3
	1:200	10	3	3	3	3:3
Y33-89F46	—	5	2	0	0	0:2
Y33-89F75	—	5	3	0	0	0:3

Immunofluorescence was used to test the virulence of the vaccine in different ECE passages and to the organs (Tables 5 and 6 respectively). Positive immunofluorescence occurred in all passages from 8 to 29 (Table 5). Strong evidence of virus was found in heart muscle and liver, but none in the organs of ECE at passage 46, except a slight positive with amnion. Virulence increased with passage number (Table 7). Different organs were titrated (Table 8).

**Table 5.** Immunofluorescence tests of different passages of ECE of the Sichuan strain.

Date	Passage no.	Results
16 October 1988	F8	+++
26 January 1989	F17	+++
1 March 1989	F20	++++
29 March 1989	F22	++++
6 May 1989	F29	++++

In safety tests, there were no clinical signs observed for 21 days in both experimental sheep inoculated with attenuated vaccine passed four times (Tables 9 and 10, Sichuan and Yunnan respectively). Challenges with virulent blood did not cause any clinical symptoms (Table 10). The two control sheep became sick.

### Vaccination experiment

In protection experiments in Yunnan and Sichuan, only one of the experimental sheep had clinical symptoms of bluetongue after challenge (Tables 11 and 12, Yunnan and Sichuan respectively). All the control sheep developed bluetongue after challenge.

Evaluation of vaccine efficiency was conducted in both Yunnan and Sichuan by calculating the titre from the results in Tables 11 and 12, together with the results of inoculating blood taken 5–120 days post-infection which had been blind passaged in ECE five times. No regular ECE death pattern was found.

**Table 7.** Titration of different passages of chick embryos.

Date	Inoculum	Titration (ID <sub>50</sub> =Log)	Remarks
2 Jun 1983	Y55-471F50	10 <sup>5.13</sup>	0.2 mL inoculated to amnion, inoculum prepared with whole body of embryo
12 Jul 1983	Y55-471F64	10 <sup>4.34</sup>	
11 Aug 1983	Y55-471F47	10 <sup>4.33</sup>	
29 Mar 1987	Y55-471F44	10 <sup>3.83</sup>	
29 Mar 1987	Y55-471F27	10 <sup>3.83</sup>	

## Discussion

ECE-attenuated vaccines, developed from local isolates from sheep sick with bluetongue in Yunnan and Sichuan, vaccinated sheep effectively (Table 4). Observation of experimental sheep showed no clinical signs on sheep at 21 days post-infection, as also found by McGowan et al. (1956).

The procedure for developing and evaluating a vaccine was established and proven in both provinces.

**Table 6.** Immunofluorescence tests of different passages of ECE of the Yunnan strain.

Inoculum via amnion		Organs of embryos			
		Muscle	Liver	Heart	Brain
Y33-89	F52*	–	–	–	–
	F54	+	++	+–	–
	F59	–	++	–	–
	F59 (vein)	–	+++	nt	nt
	F46	#	#	+++	+
Y55-447	F53*	–	–	–	–
	F57	++	++	–	–
	F65	++	++	–	–
	F74	+	++	+	–
	F75	+++	++	++	–

nt not tested

\* discarded

# inconclusive

– negative

+– trace of fluorescence

+, ++, +++ relative strength of positive fluorescence

**Table 8.** Titration of bluetongue virus vaccine in the organs of chick embryos (0.2 mL in amnion).

Organs	Inoculum (vaccine)	Titration LC <sub>50</sub> =Log
Heart	Y33-89F44, F46	10 <sup>3.33</sup>
Liver	F46, F48	10 <sup>3.5</sup>
Kidney	F52, F54	10 <sup>3.67</sup>
Brain	F42, F44	10 <sup>2.23</sup>
Amnion membrane	F53, F55	10 <sup>2.75</sup>
Amnion fluid	F56	no regular deaths seen

**Table 9.** Recovery of virulence of ECE-attenuated vaccine in sheep (Sichuan strain).

Date	Strain	Sheep without clinical signs	Leucocyte decrease	Fluctuation in body temperature	Clinical signs
26 Apr 1989	SWF22	2/2	1/2	0/2	
3 Jun 1989	SWF30	8/10	3/10	0/10	
Dec 1989	SWF35	1/3	1/3	0/3	
4 Jan 1989	SWF30	0/10	0/10	0/10	

The successful protocol using ECE-attenuated isolates to produce vaccine at 33.5–35°C had been adapted from those of Mason and Neitz (1940) and Alexander et al. (1947). Immunofluorescence testing, a reliable application for testing vaccine virulence, showed that the vaccine titre was highest (10<sup>3.6</sup>) at

**Table 10.** Virulence tests of ECE-attenuated vaccine in sheep (Yunnan strain).

No. of passages in sheep	Sheep no.	Blood inoculum 7 days post-infection	Clinical signs	Recovery of virulence
1	564	Y33-89F51	–	0/2
	565	from ECE 4 mL	–	
	576	Y33-89F113	–	0/2
2	577	from ECE 4 mL	–	
	578	from blood of 564 and 565	–	0/2
	581	from blood of 576 and 577	–	0/2
3	582		–	
	583	from blood of 578 and 588	–	0/2
	584		–	
4	585	from blood of 581 and 582	–	0/2
	586		–	
	587	from blood of 583 and 584	–	0/2
5	588		–	
	589	from blood of 585 and 586	–	0/2

passage 47 (Table 12; Zhang Nianzu et al. 1991), and tended to decrease after F60. The results suggested that the optimum passage level for developing vaccine was F46–F60. There was no difference in the effectiveness of the venous and amniotic routes for virus passage.

**Table 11.** Protection tests with ECE-attenuated vaccine in Yunnan.

Trial	Inoculum	No. of sheep	Vaccine dose	Challenge days post-infection	Subclinical	Clinical	Protected Total
1	Y33-89F46	2	5 mL	35	–	–	2/2
	Y33-89F75	3	5 mL	35	+	–	2/3
	control	2		35 (then observed for 39 days)	++	++	0/2
2	Y33-89F47	3	5 mL	35	–	–	3/3
	Y33-89F108	3	5 mL	35	–	–	3/3
	control	3		35 (then observed for 35 days)	++	++	1/3
Vaccinates							10/11
Control							1/5
	Y33-89F47	6	5 mL	14	1	0	5/6
	Y33-89F51	12	5 mL	21	1	0	11/12
	Y33-89F60	9	5 mL	21**	1	1	8/9
	Y33-89F113	2	5 mL	21**	0	0	2/2
Vaccinates							26/29
Total controls							2/12
Total							36/40



**Table 12.** Protection test of ECE-attenuated vaccine in Sichuan.

Date	Inoculum titre	No. of sheep	Vaccine and dose	Challenge inoculum	Challenge days post-infection	Protected/total
10 October 1981	10 <sup>-1</sup>	3	Y33-89F47, 5 mL per dilution	Y33F16 459, = 50 ID <sub>50</sub>	14	3/3
	10 <sup>-2</sup>	3				2/3
	10 <sup>-3</sup>	3				2/3
	10 <sup>-4</sup>	3				0/3
	PD <sub>50</sub>	10 <sup>-4.3/5</sup> mL		= 10 <sup>-3.6</sup> /mL		
26 September 1982	10 <sup>-0.93</sup>	3	Y33-89F51, 1 mL per dilution	Y33F3 565, = 01D <sub>50</sub>	21	3/3
	10 <sup>-1.69</sup>	3				3/3
	10 <sup>-2</sup>	3				3/3
	10 <sup>-2.39</sup>	3				2/3
	10 <sup>-2.69</sup>	3				0/3
	PD <sub>50</sub>			= 10 <sup>-2.64</sup> /mL		
16 November 1985	10 <sup>-1.69</sup>	5	G56 +68, 1 mL per dilution	Y33F3 778, = 25ID <sub>50</sub>	21	3/3
	10 <sup>-2</sup>	5				3/5
	10 <sup>-2.38</sup>	5				2/5
	10 <sup>-2.6</sup>	5				1/5
	10 <sup>-2.9</sup>	5				1/5
	PD <sub>50</sub>			= 10 <sup>-2.49</sup> /mL		

A comparison of vaccines in Yunnan and Sichuan showed slight differences between the two. First they differed in virulence. The products of the Yunnan virus failed to infect sheep only after passage 47 via ECE, in contrast to Sichuan's failure after passage 22 (Tables 9 and 10). While this suggested that the virulence of isolates from Yunnan was greater than that of isolates from Sichuan, the results of sheep cross-protection tests showed only slight cross-protection (Table 12). Mild clinical signs following inoculation with Sichuan inoculum were observed in sheep vaccinated with the Yunnan vaccine. The two local isolates were therefore classified as two serotypes. Retrospectively, Yunnan isolate was found (in 1994) to be BLU1 and the Sichuan isolate BLU16 (Zhang Nianzu these Proceedings).

In conclusion, ECE-attenuated vaccines have been developed successfully in Yunnan and Sichuan. For vaccine production, the recommended passage number via ECE was 46 to 60. The vaccination experiment showed that both vaccines gave a high protection rate with some cross-protection between the two. This procedure for ECE-attenuated vaccine for bluetongue is strongly recommended as the established standard technique.

## References

- Alexander, R.A. and Haig, D.A. 1951. The use of egg attenuated bluetongue virus in the production of a polyvalent vaccine for sheep. A propagation of the virus in sheep. Onderstepoort Journal of Veterinary Science and Animal Industry, 25, 3-15.
- Alexander, R.A., Haig, D.A. and Adelaar, T.F. 1947. The attenuation of bluetongue by serial passage through fertile eggs. Onderstepoort Journal of Veterinary Science and Animal Industry, 21, 231-241.
- Anon. 1989. Yunnan Tropical and Subtropical Animal Virus Diseases Laboratory, draft of standard technique of AGID test for bluetongue. Yunnan Animal Husbandry and Veterinary Journal, 4, 43-44.
- Foster, N.M., Jones, R.H. and Luedke, A.J. 1968. Transmission of attenuated and virulent bluetongue virus with *Culicoides variipennis* infected orally via sheep. American Journal of Veterinary Research, 29, 275-279.
- Foster, N.M. and Luedke, A.J. 1968. Direct assay for bluetongue virus by intravascular inoculation of embryonating chicken eggs. American Journal of Veterinary Research, 29, 749-753.
- Goldsmid, L. and Barzaili, E. 1968. An improved method for the isolation and identification of bluetongue virus by intravenous inoculation of embryonated chicken eggs.

- Journal of Comparative Pathology and Therapeutics*, 78, 477-487.
- Hu Yuling. 1991. A neutralisation test for bluetongue. *Yunnan Animal Husbandry and Veterinary Journal*, 3, 51-52.
- Hu Yuling, Li Gen, Li Zhihua and Zhang Khaili. 1989. Direct preparation of immunofluorescence antibody and application in diagnosis of bluetongue. *Yunnan Animal Husbandry and Veterinary Journal*, 4, 22-25.
- Kemeny, L. and Drehle, L.E. 1961. The use of tissue culture-propagated bluetongue vaccine virus for vaccine preparation. *American Journal of Veterinary Research*, 22, 921-925.
- Lin Lihui, Huang Qiaoling, Kang Changfeng, Zhong Liying, Li Ping, Li Bing and Song Hang. 1989. Isolation of bluetongue virus and a serological survey in Sichuan Province. *Yunnan Animal Husbandry and Veterinary Journal*, 4, 57-60.
- Mason, H.J. and Neitz, W.O. 1940. The susceptibility of cattle to the virus of bluetongue. *Onderstepoort Journal of Veterinary Science and Animal Industry*, 15, 149-157.
- McGowan, B., McKercher, D.G. and Schultz, G. 1956. Studies on bluetongue. IV. Field trial of a modified live virus vaccine. *Journal of the American Veterinary Medical Association*, 128, 454-456.
- McKercher, D.G., McGowan, B., Cabasso, V.J., Roberts, G.I. and Saito, J. 1957. Studies on bluetongue. III. The development of a modified live virus vaccine employing American strains of bluetongue virus. *American Journal of Veterinary Research*, 18, 310-316.
- Neitz, W.O. 1948. Immunological studies on bluetongue in sheep. *Onderstepoort Journal of Veterinary Science and Animal Industry*, 23, 93-136.
- Spruell, J.J. 1906. Malarial catarrhal fever (bluetongue) of sheep in South Africa. *Journal of Comparative Pathology and Therapeutics*, 18, 321-327.
- Theiler, A. 1908. Inoculation of sheep against bluetongue and results in practice. *Veterinary Journal (Transvaal)*, 64, 600-607.
- Zhang Khaili, Li Zhihua, Hu Yuling, Li Gen and Zhang Nianzu. 1991. Titration of local isolates of bluetongue virus in Yunnan. *Yunnan Animal Husbandry and Veterinary Journal*, 3, 38-40.
- Zhang Nianzu, Zhang Khaili and Li Zhihua. 1991. Study of attenuated vaccine and vaccination for bluetongue. *Yunnan Animal Husbandry and Veterinary Journal*, 3, 1-6.
- Zhang Nianzu, Zhang Khaili, Li Zhihua, Shanyu Naishun, Hu Yuling, Li Gen, Zhao Kun, Zhou Fuzhong and Xu Wenzhen. 1989. Investigation and study of bluetongue disease of sheep in Yunnan, China. *Yunnan Animal Husbandry and Veterinary Journal*, 4, 3-12.

# Cross-protection Studies of Bluetongue Viruses in Sheep

Li Zhihua, Zhang Khaili and Li Gen\*

## Abstract

Fifteen sheep were divided into five groups and inoculated with USA origin bluetongue virus (BLU) serotypes 2, 10, 11, 13 and 17 respectively (10 mL/sheep). After 42 days they were challenged with Y33F20 virulent strain. Survival rates were 0/3, 1/3, 0/3, 1/3 and 1/3 respectively. Another 15 sheep in five groups were inoculated with Y33F20 virulent Yunnan BLU (10 mL/sheep) and challenged at 42 days with USA origin BLU2, 10, 11, 13 and 17. Survival rates were 0/2, 0/3, 1/3, 0/3 and 1/3 respectively. A further group of 12 sheep were inoculated as follows: six with W53 infectious blood 5 mL/sheep; three with cell-adapted W53 10 mL/sheep; and three kept as controls. At 42 days, all were challenged with SF6 (Sichuan) and W53 (Hubei) strains at 1 mL/sheep. In each group 1/3 survived, and all controls were sick or died. These results indicate that Yunnan, Sichuan and Hubei strains are different serotypes and that the Yunnan strain is different from serotypes BLU2, 10, 11, 13 and 17 of USA origin.

CROSS-PROTECTION experiments were developed for studying different isolates of bluetongue virus (BLU). Neitz (1948) was the first to use the technique for bluetongue. Subsequently many scientists worked to develop multiple vaccines, identifying and studying the properties of different BLU isolates (Alexander and Haig 1951; McKercher et al. 1957; Luedke and Jochim 1968). More recently, cross-protection tests have been used to identify specific properties of local BLU isolates from Yunnan (Zhang Nianzu et al. 1989), Hubei (Li Zhihua et al. 1989) and Sichuan (Lin Lihui et al. 1989) in comparison with standard serotypes BLU2, 10, 13 and 17.

## Materials and Methods

### Chinese isolates

1. Y33F20 and Y33F22; isolated from blood of bluetongue-diseased sheep with fever, passaged through sheep 20 and 22 times respectively, then stored at 4°C.

2. W53; isolated from the blood of experimental sheep with fever by inoculating specimen from a sick sheep, stored at 4°C.
3. Y26; Yunnan isolate, passaged in BHK21 cell 26 times, harvested and stored at -80°C.
4. WF5; Hubei isolate, passaged in BHK21 cell 26 times, harvested and stored at -80°C.
5. SF2 and SF6; isolated from blood of sheep with fever, inoculated with a specimen from Sichuan, passaged in sheep twice (SF2) and six times (SF6) stored at 4°C.

### Standard foreign strains

Five BLU serotypes from the National Virus Standards Institute, USA, passaged in BHK21 cells and stored at -80°C, were used as standards.

### Experimental animals

Healthy Xinjiang Merino sheep, tested as BLU-free before the experiment, were used, with body temperatures and leucocyte counts recorded.

### Treatments

1. Fifteen sheep were divided into five groups (three sheep per group), given an inoculum of 1 mL/

\* Yunnan Tropical and Subtropical Animal Virus Diseases Laboratory, Jindian 650224, Kunming, People's Republic of China.

sheep of each standard BLU serotype, and challenged with 1 mL/sheep of YF20 isolate.

2. Fifteen sheep were divided into five groups (three sheep per group), given an inoculum of 1 mL/sheep of YF20 isolate, and challenged with 1 mL/sheep of each standard BLU serotype.
3. Twelve sheep were divided into three groups: six sheep were inoculated with 5 mL/head of W53; three sheep with 10 mL/head of WF5; and three sheep given no treatment as a control. All were challenged with 0.2 mL/head of YF22 at 42 days post-infection.
4. Eight sheep were divided into three groups: three sheep were inoculated with 5 mL/head of Y26; three sheep with 2 mL/head of YF20; and two remained untreated as controls. The two treated groups were challenged with 1 mL/head of SF2 + SF6 or W53 respectively and the control group was inoculated with SF2 plus SF6.

### Observations

Observations followed each treatment and trial for 15 successive days, measuring clinical signs twice a day and leucocytes every two days. An animal with clinical signs, a 1°C increase in body temperature or a one-third decrease in leucocyte count, was considered to have a positive reaction.

**Table 1.** Cross-protection tests of Yunnan isolate with five standard BLU strains passaged in BHK21 cells.

Trial no.	Group	Inoculum		No. protected/ total no.
		Inoculation	Challenge	
1 (28 November 1985)	1	BLU1	Y33F20	0/3
	2	BLU10		1/3
	3	BLU11		0/3
	4	BLU13		1/3
	5	BLU17		1/3
2	1	Y33F22	BLU10	0/3
	2		BLU2	0/2
	3		BLU17	1/3
	4		BLU11	1/3

### Results and Discussion

The results of cross-protection tests comparing a Yunnan isolate with standard BLU serotypes, and with local Yunnan, Hubei and Sichuan isolates, showed there was no cross protection within any two isolates

of paired groups (Tables 1 and 2). Yunnan isolate was therefore different from BLU2, 10, 11, 13 and 17. Agar gel immunodiffusion (AGID), immunofluorescent antibody (IFA) and nucleic acid polyacrylamide gel electrophoresis (PAGE) indicated that the bluetongue group specific properties of the local isolates, including Yunnan, Hubei and Sichuan, were the same as those of BLU2, 10, 11, 13 and 17 (Hu Yuling and Peng Kegao 1989). However, these local isolates may belong to different serotypes: this aspect needs further study.

**Table 2.** Cross-protection tests in sheep with Yunnan (Y), Hubei (W) and Sichuan (S) local isolates of bluetongue viruses.

Trial no.	Group	No. of sheep	Inoculum	Challenge	Protected/ total
3	1	6	W53	Y33F22	2/6
	2	3	WF4	Y33F22	1/3
	control	3	-		0/3
4 (10 June 1987)	1 <sup>a</sup>	3	YF26	SF2-6	1/3
	2 <sup>b</sup>	3	YF20	W53	0/3
	control	2	-	SF2-6	0/2

<sup>a</sup> Inoculated 18 February 1989

<sup>b</sup> Inoculated 11 January 1986

### References

- Alexander, R.A. and Haig, D.A. 1951. The use of egg attenuated bluetongue virus in the production of a polyvalent vaccine of sheep. *Onderstepoort Journal of Veterinary Science and Animal Industry*, 25, 3-15.
- Hu Yuling and Peng Kegao. 1989. Analysis of local isolates of bluetongue in China by SDS-PAGE. *Yunnan Animal Husbandry and Veterinary Journal*, 4, 26-28.
- Leudke, A.J. and Jochim, M.M. 1968. Clinical and serologic responses in vaccinated sheep given challenge inoculation with isolates of bluetongue virus. *American Journal of Veterinary Research*, 29, 841-851.
- Lin Lihui, Huang Qiaoling, Kang Changfeng, Zhong Liying, Li Ping, Li Bing and Song Hang. 1989. Isolation of bluetongue virus and a serological survey in Sichuan Province. *Yunnan Animal Husbandry and Veterinary Journal*, 4, 57-60.
- Li Zhihua, Zhang Khaili, Zhou Fuzhong, Hu Yuling, Zhao Kun, Li Gen, Wu Dexing, Peng Kegao and Zhou Yong. 1989. Isolation and identification of the Hubei strain of bluetongue virus. *Yunnan Animal Husbandry and Veterinary Journal*, 4, 49-52.
- McKercher, D.G., McGowan, B., Cabasso, V.J., Roberts, G.I. and Saito, J. 1957. Studies on bluetongue. III. The development of a modified live virus vaccine employing

American strains of bluetongue virus. *American Journal of Veterinary Research*, 18, 310-316.

Neitz, W.O. 1948. Immunological studies on bluetongue in sheep. *Onderstepoort Journal of Veterinary Science and Animal Industry*, 23, 93-136.

Zhang Nianzu, Zhang Khaili, Li Zhihua, Hu Yuling and Li Gen. 1989. Investigation and study of bluetongue disease in Yunnan, China. *Yunnan Animal Husbandry and Veterinary Journal*, 4, 28-29.

# Development of Inactivated Vaccines for Bluetongue in China

Li Zhihua, Peng Kegao, Zhang Khaili, Li Gen, Hu Yuling,  
Zhou Fuzhong and Liu Gui\*

## Abstract

Bluetongue virus (BLU) strains Y863F6 and WF13, passaged in BHK21 cell culture, were inactivated by Cobalt gamma rays or hydroxylamine for vaccine development. The inactivated viruses were passaged three times in BHK21 cell culture to test inactivation efficiency and were inoculated into sheep for safety tests. As a potency test, the vaccinated sheep were challenged with 100 TCID<sub>50</sub> of the homologous virulent viruses in sheep blood after vaccination. The effect on the BLU RNAs was tested by polyacrylamide gel electrophoresis (PAGE). Bluetongue virus was not killed by irradiation with 2.5, 5 or 10 million gamma radiation (Grad). The Y863F6 virus irradiated with more than 2.5 million Grad showed no cytopathic effect (CPE) in BHK cells but the virus that received one million Grad showed CPE in the inactivation efficiency test. Sheep inoculated with viruses irradiated with 2.5 million Grad did not show any clinical reactions in the safety test. At 42 days post vaccination, the 2.5 million Grad group had good protection (10/12), the 5 million Grad group had less (2/5) and the 10 million Grad group none (0/5). Thus 2.5 million Grad is the recommended dose for an inactivated vaccine. Hydroxylamine is the best inactivator for BLU vaccine. The inactivated viruses were blind passaged in BHK21 cell culture three times. No CPE developed. The 17 inoculated sheep did not show any clinical reactions in the safety experiment. On the 42nd day after vaccination, 5/5 vaccinated sheep showed no clinical reaction but 2/2 controls did. At 205 days after vaccination 7/10 vaccinated sheep were still protected. However, 7/10 control sheep showed clinical reactions in the potency test. PAGE showed that the amine chemical can destroy BLU genome RNA. Vaccines made from BLU virus killed by the amine chemical have been used against bluetongue disease in epidemic areas in Hubei Province. Of the 7878 sheep vaccinated, none have shown subsequent clinical reactions. Bluetongue disease has been effectively controlled in these areas.

THE key element in preventing bluetongue was the development of vaccines. An attenuated vaccine has been widely used in many countries, including South Africa, USA (Stott et al. 1985) and China. However, such vaccines have disadvantages, including abortion in pregnant ewes; a long residual period; and genetic recombination in multiple vaccines. Attenuated vaccines may lead to the occurrence of bluetongue disease in non-epidemic areas by reversion to virulence (Foster

et al. 1968). It was thus necessary to develop an inactivated vaccine to prevent bluetongue. This paper reports on further experimentation in the development of an inactivated vaccine, based on previous studies by Zhang Nianzu et al. (1991) and Stott et al. (1985).

## Materials and Methods

### Isolates

The four isolates used as parent stock for developing inactivated vaccines were:

- Y863F6, a local Yunnan isolate, passaged three times in BHK21 cells;

\* Yunnan Tropical and Subtropical Animal Virus Diseases Laboratory, Jindian 650224, Kunming, People's Republic of China.

- YF13, local Hubei isolates passaged three times in BHK21 cells;
- Y33F4, a local virulent Yunnan isolate, from bovine blood in an epidemic area; and
- YWF4(116), a local virulent Hubei isolate, from blood of sheep in a high prevalence area.

### Animals

Experimental animals were healthy bluetongue-negative Xinjiang Merino sheep, clinically healthy and free of antibodies as assessed by AGID.

### Inactivation procedures

Inactivation radiation doses of Cobalt 60 gamma rays at 1, 2.5, 5 and 10 million gamma radiation (Grad) were used, from a cobalt source located in Atomic Applied Technique Institute, Sichuan Province. The chemical used was hydroxylamine (manufactured by Sigma, Germany). BHK21 monolayers with 70% cytopathic effect (CPE) due to bluetongue viruses were inactivated with gamma rays in a gamma-ray treated inoculum.

For chemical inactivation, the BHK21 cells were harvested the same way, frozen and thawed alternately, then were lysed by ultrasonication. The culture was concentrated to 1/10 volume and inactivated with hydroxylamine (Zhang Nianzu et al. 1991).

As safety tests (all repeated three times), BHK21 monolayer cells were inoculated with each of the inactivated vaccines, blind passage three times and the CPE recorded daily. Uninoculated cells were used as controls.

### Radiation-inactivated vaccine trial

Two sheep were vaccinated with 1 mL each of gamma-ray treated inoculum, with a second dose given a week later. At 42 days postvaccination, the sheep were challenged with virulent virus at a dose

of 100ID<sub>50</sub> per sheep. Three other sheep were inoculated with untreated inoculum, while another two were kept unvaccinated as controls. Clinical signs were recorded, body temperature measured twice daily and leucocyte numbers measured every two days. Animals showing a 1°C rise in body temperature, a one-third decrease in leucocyte numbers and clinical signs were considered unprotected.

### Chemically-inactivated vaccine trial

Five sheep were vaccinated with a chemically inactivated inoculum, 12 were vaccinated for morphology studies, and four were inoculated with untreated inocula as controls. Challenge with virulent isolates was at 42 days postvaccination. Similar supporting observations were made.

### Evaluation

The microneutralisation test (Hu Yuling 1991) was used to evaluate vaccine effectiveness in generating antibodies.

## Results

Comparison of the inactivated vaccines showed that there was no CPE in the test BHK21 cell cultures except for the group which received 1 million Grad (Table 1). This dose level was not used in the vaccination test in the two repeat trials. A few animals showed bluetongue signs and leucocyte changes in the repeat experiment at doses of 2.5, 5 and 10 million Grad (Table 2). The same results were obtained from all three replicate trials.

The vaccination tests showed that there were obvious differences of protection rate and level of neutralisation antibodies (Table 3) between or among each dose of gamma-ray treatment and treatments of inactivation (Table 4).

**Table 1.** Cytopathic effect (CPE) in BHK21 cell cultures inoculated with radiation- or chemically-inactivated bluetongue vaccine.

Treatment		BHK21 cell CPE (passage)			Remarks
		1	2	3	
Chemical	hydroxylamine	-	-	-	same in three trials
	control	++	+++	+++	
Gamma radiation	1 million	+	++	+++	same in three trials
	2.5 million	-	-	-	
	5 million	-	-	-	
	10 million	-	-	-	
	control	++	+++	++	

**Table 2.** Reactions of sheep after vaccination with gamma-ray inactivated bluetongue vaccine.

Vaccination	Gamma-radiation (MGrad)	No. of animals	No. of sheep with reactions			No. reacted/total no.
			BLU	Leucocyte change	Clinical signs	
1st	2.5	2	0	0	0	0/2
	5	2	0	0	0	0/2
	10	2	0	0	0	0/2
	control	3	2	3	3	3/3
2nd	2.5	10	4	2	0	2/10
	5	3	2	2	0	2/3
	10	3	0	0	0	0/3

**Table 3.** Neutralisation tests of sheep vaccinated with gamma-ray inactivated bluetongue vaccine.

Group	Sheep no.	Gamma-radiation (MGrad)	Serum dilution 14 days post-infection					Serum dilution 42 days post-infection				
			1:2	1:4	1:8	1:16	1:32	1:2	1:4	1:8	1:16	1:32
1	871	10	+	-	+	-	-	+	+	-	-	-
	872		+	+	+	-	-	+	+	+	-	-
2	873	5	+	-	-	-	-	+	+	-	-	-
	874		+	+	-	-	-	+	-	-	-	-
3	875	2.5	+	-	-	+	-	+	-	+	-	-
	876		+	+	+	+	-	+	+	+	+	-
4	8811	control	0*	0	0	0	0	+	+	-	-	-
	882		0	0	0	0	0	+	+	-	-	-

\* 0 indicates case in which animal was not inoculated with virulent inoculum but titration of sera was above 1:16.

**Table 4.** Protection rate of gamma-ray inactivated bluetongue vaccine

Challenge	Gamma-radiation (MGrad)	No. of sheep in group	No. of sheep that reacted			No. protected/total no.
			BLU	Leucocyte change	Clinical signs	
1st	2.5	2	0	0	0	2/2
	5	2	2	2	0	0/2
	10	2	2	2	0	0/2
	inactivated vaccination	3	0	0	0	3/3
	control	2	2	2	2	0/2
2nd	2.5	10	2	2	0	8/10
	5	3	1	1	0	2/3
	10	3	3	3	0	0/3
	control	2	2	2	2	0/2

The protection test using chemically-inactivated vaccine showed there were no bluetongue signs and leucocyte changes in the five experimental sheep. (Morphological results are reported in another paper in these Proceedings.)

## Discussion

The five sheep vaccinated with inactivated material were protected effectively (protection rate 100% 42 days post-vaccination) by the vaccine. These results



show that chemical inactivation is a valuable approach to developing a bluetongue vaccine.

The effectiveness of a radiation inactivation vaccine must focus on the dose of radiation. Failure to inactivate BLU occurred at 1 million Grad (Table 1) and failure to protect sheep from inoculation of virulent BLU at 10 million Grad (Tables 2, 4). This result differs from that of Campbell (1985) who reported that a dose of 6–10 million Grad had no effect on the vaccine's protective effect. The moderate dose of radiation in this experiment, 2.5 million Grad Cobalt-60, had a high protection rate (85% at 42 days post-vaccination), without any clinical and subclinical reactions after vaccination (Table 2). Possibly this was related to a lymphocyte transformation (Stott et al. 1979, Jeggo and Wardley 1982). This was similar to the results of Huisman's animal vaccinated with purified VP2, which demonstrated that the 2.5 million Grad was not harmful to the VP2 protein. The vaccine nucleic acid was not structurally changed by the inactivation procedure (Peng Kegao et al. these Proceedings).

In summary, hydroxylamine is a safe and effective inactivant for bluetongue vaccine. Gamma irradiation (2.5 million) by Cobalt-60 was recommended as an alternative method for inactivation.

## References

- Campbell, C.H. 1985. Immunogenicity of bluetongue virus inactivated by gamma irradiation. *Vaccine*, 3, 401–406.
- Foster, N.M., Jones, R.H. and Luedke, A.J. 1968. Transmission of attenuated and virulent bluetongue virus with *Culicoides variipennis* infected orally via sheep. *American Journal of Veterinary Research*, 29, 275–279.
- Hu Yuling. 1991. A neutralisation test for bluetongue. *Yunnan Animal Husbandry and Veterinary Journal*, 3, 51–52.
- Jeggo, M.H. and Wardley, R.C. 1982. Production of murine cytotoxic T lymphocytes by bluetongue virus following various immunization procedures. *Research in Veterinary Science*, 33, 212–215.
- Stott, J.L., Barber, T.L. and Osburn, B.I. 1979. The current status of research on an experimental bluetongue vaccine. *Proceedings 83rd Annual Meeting US Animal Health Association*, 55–62.
- 1985. Immunological response of sheep to inactivated and virulent bluetongue virus. *American Journal of Veterinary Research*, 46, 1043–1048.
- Zhang Nianzu, Li Zhihua, Zhang Khaili, Peng Kegao, Li Gen, Hu Yuling, Wu Dexing, Zhou Fuzhong and Zhao Kuen. 1991. Studies on inactivation of bluetongue vaccines. *Yunnan Animal Husbandry and Veterinary Journal*, 3, 10–13.

# Analysis of RNA of Inactivated Bluetongue Vaccine by PAGE

Peng Kegao, Li Zhihua and Wu Dexing\*

## *Abstract*

Hydroxylamine and gamma-ray inactivated vaccines show a promising future. We have previously reported that, at a certain dose, gamma-rays could destroy the viral genome while maintaining immunogenicity; and that hydroxylamine could destroy pyrimidine while also maintaining immunogenicity. We now report having used RNA-polyacrylamide gel electrophoresis (PAGE) to analyse the vaccines to understand the mechanism of inactivation. The results uniformly revealed that viral segments 1 to 3 were degraded into low molecular weight compound after exposure to  $2.5 \times 10^6$  rad on PAGE: segment 4 was partly degraded and segments 5 to 10 were affected. The hydroxylamine-inactivated samples showed slower migration and rocket-like bands. All controls displayed 10 bands with a typical profile of 3, 3, 3, 1. All inactivated samples failed to produce cytopathic effect (CPE) on BHK21 cells. Gamma-rays therefore inactivate bluetongue viruses by degrading their RNA. Hydroxylamine did degrade dsRNA but might affect the end of dsRNA or the pyrimidine. Whether the affected dsRNA could continue to serve as a template remains to be tested. RNA-PAGE could be used as a method to understand the mechanism of inactivation of bluetongue viruses.

---

\* Yunnan Tropical and Subtropical Animal Virus Diseases  
Laboratory, Jindian 650224, Kunming, People's Republic of China.

# The Prevention and Control of Bluetongue Disease in China

Wang Qinbo\*

## Abstract

This paper reports on the isolation of bluetongue virus, and the distribution, prevention and control of bluetongue disease in China since 1979. At present, the integrated preventative and control measures involve: control of infectious agents; checking of cattle and sheep imported from infected areas; monitoring and control of animals in genetically important stud stock; control of vectors; and developing vaccines with the major virus serotypes. Vaccination has already controlled the incidence of clinical disease in sheep in China.

BLUETONGUE disease is a non-contagious infectious disease that mainly affects sheep and other ruminants. The first diagnosis of bluetongue in China was made in 1979, and was followed by epidemiological and serological surveys throughout China. At that time prevention and vaccination were emphasised as control measures. This paper reports the surveys and control measures for bluetongue in China since 1979.

## General Survey

An epidemiological survey of bluetongue was begun after the first outbreak in Yunnan in 1979 (Zhang Nianzu et al. 1989b): serological statistics from epidemic areas are shown in Table 1. The morbidity caused by bluetongue in epidemic areas was 8.2–35%, with mortality rates from 20% to 30% among the sick animals. The geographical distribution of bluetongue extended from the southern areas to as far north as 35–37°N. At the northern area's southern limit, at about 35–45°N, the incidence of the disease was low. Susceptible animals included sheep which had clinical signs and cattle which did not show clinical signs. Most affected were pure breed Merino sheep introduced from southern areas both domestic and abroad.

Susceptible ruminants, including sheep in epidemic areas (Table 1) and cattle in 29 Provinces (Table 2) were surveyed using an agar gel immunodiffusion (AGID) test (Zhang Nianzu et al. 1989a). High positive rates for cattle occurred in the southern areas, while few positive cattle were found in Xinjiang and Inner Mongolia. The provinces of Qinghai, Heilongjiang and Jilin were bluetongue-free. The high prevalence of antibodies in cattle suggested they were the major potential source of epidemics in China.

**Table 1.** Serological survey using AGID of bluetongue in sheep and goats in epidemic Provinces, 1979–1989.

Year	Province	No. of animals surveyed	No. of positives (%)
1979–1984	Hubei	1972	146 (7.4)
1983–1989	Yunnan	19 290	3354 (17.4)
1984–1989	Hubei	3990	182 (4.6)
1986–1988	Inner Mongolia, Sichuan, Tibet	6342	1171 (18.5)
1987–1989	Anhui, Hubei, Hebei	8720	2553 (29.3)
Total		40 314	7406 (18.4)

\* Department of Animal Husbandry and Veterinary Medicine, Ministry of Agriculture, Beijing 100026, People's Republic of China.

**Table 2.** Serological survey by AGID of antibodies to bluetongue in cattle in epidemic Provinces, 1979–1989.

Year	Province	No. of cattle reared	No. positive	% positive
1979	Yunnan, Hubei		430	
1983	Yunnan	6 707 100	199	0.0029
1985	Yunnan, Hubei, Guangxi	15 586 900	4418	0.0266
1987	Yunnan, Shandong, Anhui, Hebei	17 173 700	381	0.0022
1988	Yunnan, Shandong, Hebei, Zhejiang, Xinjiang, Hainan	2 339 743	1460	0.0624
1989	Total 26 Provinces (excluding Qinghai, Heilongjiang and Jilin)	98 824 909	12126	0.0123
Total	China	141 632 352	19 014	0.0134

### Control Strategy for Bluetongue in China

Strategies for controlling bluetongue in China have involved the control of acute outbreaks, monitoring, vaccination, quarantine, the control of products and the destruction of insect vectors.

The initial, basic but effective, strategy used to control the spread of the infectious disease was the killing of animals which were clinically ill during outbreaks and isolating the outbreak areas. During the acute out-

breaks in China between 1981 and 1984, 4567 ruminants were killed. To monitor the prevalence of bluetongue, another strategy was the establishment of several sentinel flocks of animals in epidemic areas (described elsewhere in these Proceedings). These sentinels showed a decrease in the AGID positive rate from 36.6% to 2.3%.

Other strategies involved strict quarantine and testing. The introduction of breeds from both domestic and foreign regions with a history of epidemic bluetongue was controlled, with the AGID test used to identify infected animals. Germplasm, such as frozen semen, and the associated instruments for the artificial insemination of breeding animals, was also tested for the presence of bluetongue viruses.

On many farms, effective use of insecticides as animal dips decreased the attack of vector insects such as *Culicoides*.

Finally, the most important strategy for controlling bluetongue was vaccination, using attenuated and inactivated vaccines. These vaccines were developed successfully in China, a great research achievement. The results of vaccination were very successful in China, and this strategy will be emphasised and improved in future research.

The effectiveness of all these strategies for controlling bluetongue in China has been proved by the decrease in the incidence and serological prevalence of the disease in sheep and cattle.

### References

- Zhang Nianzu, Zhang Khaili, Li Zhihua, Hu Yuling, Li Gen, Zhao Kun, Zhou Fuzhong and Shanyu Naishun. 1989a. Application of agar gel immunodiffusion test for the diagnosis of bluetongue in animals. *Yunnan Animal Husbandry and Veterinary Medicine*, 4, 17–19.
- Zhang Nianzu, Zhang Khaili, Li Zhihua, Shanyu Naishun, Hu Yuling, Li Gen, Zhao Kun, Zhou Fuzhong and Xu Wenzhen. 1989b. Survey and studies of bluetongue in sheep. *Yunnan Animal Husbandry and Veterinary Journal*, 4, 3–12.

# Developments and Advances in the Prevention of Bluetongue Disease

Feng Jinglan\*

## Abstract

This paper reports developments and advances in the prevention and control of bluetongue disease in China. Since bluetongue was first recognised in China in 1979, there have been systematic studies of its pathogenesis, epidemiology, pathological processes, diagnosis, vaccination, disease monitoring and immune mechanisms. Two serotypes have been used in a modified live virus vaccine, and killed vaccine has been used to vaccinate sheep in isolated foci in southern China. Carried out one to two months before expected outbreaks, this vaccination program has controlled the incidence of clinical disease. A virus isolate from Northern China did not produce clinical disease when inoculated into sheep. The virus-carrying animals (cattle, goats etc.) are latent carriers and thus the source of viruses which cause disease. Development of more rapid diagnostic methods, applications of molecular techniques, monitoring of major serotypes and isolation of viruses should continue. Quarantine measures, disposal of diseased animals and annual or regular vaccination will assist in the control of disease and in minimising economic losses.

BLUETONGUE viruses (BLU) mainly attack ruminants. Sheep, particularly fine wool sheep (Merino), are most sensitive. BLU viruses cause bluetongue disease and produce high mortality. Cattle and other ruminants are often silent BLU carriers with no clinical signs, but are potential sources for the spread of disease. The importance of prevention is becoming more and more obvious in animal production.

Through many studies on bluetongue, much progress has been made in understanding BLU pathogenesis, epidemiology, immunology and appropriate research methodologies. However, as the viruses are carried by insects, the size of the epidemic area increases annually. The study of this aspect has attracted many scientists throughout the world.

In China, there were no records of this disease until the outbreak and isolation of bluetongue in Shizong, Yunnan in 1979. Many basic bluetongue studies, including aetiology, pathogenesis, immune mechanisms, clinical diagnosis, immunoserology and

vaccine production, have supported the need to prevent the disease. This paper reviews the progress of preventative technology and its applications to bluetongue disease in China.

## Distribution of Bluetongue in China

Outbreaks of bluetongue in China have been reported in Yunnan (1979), Hubei (1983), Anhui (1985), Sichuan (1988) and Shanxi (1993). The geographical limits of the epidemic areas are confined to the southern part of China as far north as latitude 35–37°N. Serological surveys have shown that 29 Provinces have seropositive animals. The higher positive rates were in sheep in Yunnan and Guangxi among the southern provinces, and in goats in Inner Mongolia. In the other Provinces with seropositive animals, the positive rate was from zero to 4.7%. In cattle, the prevalence of bluetongue antibodies, using AGID, was 0.01%, except for Inner Mongolia and Qinghai, Jilin and Heilongjiang Provinces in the far north. No clinical signs have been found in any seropositive cattle or buffalo. No camels tested have been positive for antibodies.

---

\* Department of Veterinary Medicine and Animal Husbandry, Ministry of Agriculture, Beijing 100026, People's Republic of China.

## Practical Techniques for Preventing Bluetongue

After the confirmation and isolation of BLU in 1979, a systematic study of ways of preventing bluetongue was conducted, with the Yunnan group as leaders collaborating with the National Quarantine Institute, Harbin Veterinary Research Institute (which belongs to the Chinese Agricultural Academy of Science) and the corresponding provinces. Bluetongue viruses were successfully isolated from sheep in Yunnan, Hubei, Anhui, Sichuan and Shanxi Provinces, and from sentinel animals in Inner Mongolia and Xinjiang, Shandong and Gansu Provinces. Inoculation experiments showed that none of the isolated viruses, whether from natural sick animals or from sentinels, could cause clinical signs in animals.

The major serotypes in China are now recognised as BLU1 and BLU16. Successful testing technologies have been evolved (AGID, cELISA etc.), and these have been standardised and expanded all over China. The successful production of egg embryo vaccines (from the Yunnan strain) and BLU16 (from the Sichuan strain) was an important fundamental step towards the prevention of bluetongue in China.

The comprehensive study to prevent bluetongue in China involved a primary stage and a vaccination stage.

### Primary stage

Preventing and controlling the spread of bluetongue from the outbreak site: by using quarantine measures, isolation of sick animals, quarantine of the epidemic area, insect destruction on grassland where the epidemic occurred and surrounding areas and by slaughtering the sick and suspect animals. This stage lasted from 1979 to 1984. A total of 4567 animals (740 sick or suspected cattle and 3827 sheep) were

slaughtered, which resulted in a sharp drop in the rate of seropositives in sheep from 35.9% to 2.3% compared to a seropositive rate of 16.3% in cattle and 8.9% in buffalo. It thus appeared that this approach was effective in preventing bluetongue in sheep.

### Vaccination stage

The egg embryo attenuated vaccines of BLU1 and BLU16 and the inactivated antigen of these viruses were successfully produced. Many basic studies have been completed in the last decade. Preventing bluetongue in China was being accomplished through a comprehensive program of vaccination combined with the above sanitary measures. Progress in practical prevention included establishing sentinel herds, restricting the movement of and quarantining seropositive animals, and improving sanitation in animal housing and on farms. A total of 120000 animals were vaccinated (Table 1). The results showed that the protection rate of embryo attenuated vaccine was greater than 90%, with a period of immunity lasting one year, and up to 80% protection rate after one year. The inactivated vaccine gave immunity lasting more than six months. Full protection was gained by vaccinating two months before the epidemic season.

To establish vaccination schemes in areas where the BLU serotype infecting animals has not yet been identified, a combined vaccine (two types of attenuated vaccine) should be used to prevent multiple infections with bluetongue viruses. Comprehensive prevention procedures in China over the last decade have been fully successful in some previous outbreak areas in the southern Provinces. Further preventative strategies should focus on studies of vaccine development, vaccination, establishment of a standard vaccination regime, monitoring for BLU and antibodies in sentinel herds and strict protection of non-epidemic areas.

Table 1. Preventative vaccination of bluetongue in some Provinces of China.

Region	Years	Vaccine used	Number of vaccinated animals	Evaluation of outcome
Hongchiba, Sichuan	1989-1995	BLU1, BLU16 (chick embryo attenuated)	84000	Prevented bluetongue effectively
Xianfan, Hubei	1989-1994	BLU16 (inactivated antigen)	12000	Prevented bluetongue effectively plus protection rate of 70% 205 days post-vaccination
Jiangsu Province	1994-1995	BLU1, BLU16 (chick embryo attenuated)	16000	Prevented bluetongue effectively
Shanxi Province	1995	BLU1, BLU16 (chick embryo attenuated)	8000	Prevented bluetongue effectively

# **Open Forum and Finale**

# Introduction

RESTRICTIONS on the international movement of ruminants from bluetongue endemic areas to bluetongue-free areas, and even between countries with endemic bluetongue, have evolved from the proposition that once a cow, sheep, goat, buffalo or other ruminant has been infected with a bluetongue virus it may be infected for life. Thus both the live animal and its germplasm were considered risks by being potential sources of virus.

The information presented in these Proceedings, and especially in the next three papers, was discussed in various ways during the course of the Symposium. In the Open Forum, in the final stages of the Symposium, the following points were not disputed.

- Infection with a bluetongue virus is of finite duration. Virus components become undetectable, even by PCR, at the end of the life span of a red cell, approximately 150 days.
- The blood of infected ruminants is infective experimentally to other ruminants for a very much shorter period than this, certainly not longer than two months (the limit at which live virus has been isolated from blood): usually the period of viraemia in natural infections is much shorter.
- The excretion of bluetongue virus in semen can occur, but uncommonly, when a bull is infected with attenuated virus, and very rarely occurs in naturally infected bulls. Any excretion of virus into semen occurs only during viraemia.
- There is no evidence that immune tolerance is induced in cattle or sheep infected in utero.
- Both field and laboratory evidence suggest that bluetongue virus does not overwinter in cattle. The value of diagnostic tests, and their interpretation, was also discussed in the Open Forum.
- The bluetongue complement fixation test is not routinely used in laboratories in the Southeast Asia and Pacific region, as represented by delegates at this Symposium, except for purposes of import or export.
- There was agreement that the complement fixation test is prone to error; is highly cross-reactive, causing many false positives; and is impossible to standardise internationally. Its use should be ended.
- Competitive enzyme linked immunosorbent assay (cELISA) was considered more sensitive and specific to the bluetongue serogroup than agar gel immunodiffusion (AGID), and should replace the latter where possible.
- The detection of bluetongue antibodies in serum collected from a ruminant should not be interpreted as meaning that the animal has live virus circulating in its body. The time since the animal may have been exposed to infection should also be considered.



# Bluetongue Virus Infection of Postnatal Cattle

N.J. MacLachlan\*

## *Abstract*

Bluetongue virus (BLU) infection of cattle is common throughout tropical and temperate areas of the world. Cattle appear to act as reservoir hosts in which virus amplification occurs. Haematophagous insects then transfer BLU to sheep and other ruminants which are more susceptible to bluetongue disease. Chronically infected cattle have been considered responsible for disseminating BLU, but this notion has not been adequately substantiated. Present knowledge suggests that vertical transmission is unimportant in BLU epidemiology. However, evidence confirms that typically viraemia is prolonged in BLU-infected cattle, but that the vast majority of infections are asymptomatic. Recent studies have characterised better the pathogenesis of BLU infections in cattle. The virus replicates primarily in the lungs and lymphoid tissues (lymph nodes and spleen) of infected cattle, and the association of virus with blood cells facilitates a prolonged viraemia of up to 50 days or even longer. Using polymerase chain reaction (PCR) tests, viral nucleic acid may be detected in blood cells for longer still (approximately 150 days), but there is no evidence that infectious virus can be recovered ('rescued') by insect vectors from cattle with blood that is positive by PCR analysis but not by virus isolation. We suggest that red blood cells facilitate prolonged viraemia in infected cattle, by protecting circulating virus from the immune system, and infection of haematophagous insects, which disseminate virus to other species. Furthermore, we conclude that viral nucleic acid persists in infected ruminants only for the life span of red blood cells (approximately 150 days in cattle and slightly less in sheep), and that infectious virus is present in blood for an even shorter period.

BLUETONGUE is an insect-transmitted viral disease that occurs sporadically among populations of sheep and certain wild ruminant species (Spreull 1905; Ozawa 1984, Erasmus 1985). Bluetongue virus (BLU) infection of cattle is common throughout tropical, subtropical, and some temperate regions of the world, whereas bluetongue disease typically is encountered only in temperate regions, or when susceptible ruminants are introduced into bluetongue-endemic regions within the tropics and subtropics (Gibbs 1983, 1992; Ozawa 1984; Barratt-Boyes et al. 1995). The significance of bluetongue infection in cattle is that virus amplification occurs in infected cattle before virus is disseminated by haematophagous insects. Cattle have thus been considered as reservoir hosts that facilitate 'overwintering' of BLU at times when the vector population is low or absent

(Du Toit 1962; Nevill 1971; MacLachlan 1994; Barratt-Boyes et al. 1995). Suggestions that cattle serve as BLU amplifiers and reservoirs reflect the knowledge that BLU infection of cattle is very common in endemic areas, that invariably such infections are asymptomatic (Osburn et al. 1981) and, most important, that viraemia may be prolonged in infected cattle (Du Toit 1962; Luedke et al. 1969; Luedke 1970; Nevill 1971; MacLachlan et al. 1987, 1990b; Barratt-Boyes and MacLachlan 1994). Luedke et al. (1977a, b, c, 1982) proposed that persistently infected cattle were important BLU reservoirs while Howell (1963) considered bluetongue to be an emerging disease being spread throughout the world by persistently infected cattle. As a direct consequence of this notion of cattle as reservoir BLU hosts, countries free of the virus have restricted or banned the importation of ruminants and/or their genetic products (semen/embryos) from countries in which infection is endemic (Gibbs 1983; Roberts et al. 1993; Barratt-Boyes and MacLachlan 1994). The principal justification for such restrictions is the fear that BLU might

---

\* Department of Pathology, Microbiology and Immunology, School of Veterinary Medicine, University of California, Davis, California 95616, USA.

be spread by trade and animal movement between countries. However, current evidence suggests that this risk is minimal when appropriate precautions are taken. Furthermore, as members of the BLU group exist in distinct, relatively stable ecosystems in different regions of the world (Gould and Pritchard 1990; de Mattos et al. 1994), bluetongue cannot be considered an emerging disease recently spread by persistently infected cattle.

## Pathogenesis of Bluetongue Infection of Cattle

Although, typically, BLU infection of neonatal and adult cattle is asymptomatic, infection is followed frequently by a prolonged cell-associated viraemia (Du Toit 1962; Owen et al. 1965; Jochim et al. 1974; MacLachlan et al. 1987, 1990a, 1994; Barratt-Boyes and MacLachlan 1994; Katz et al. 1994). Infected cattle mount a prompt and high-titred humoral immune response but virus and specific neutralising antibody often circulate together in blood for some weeks (Luedke 1970; MacLachlan et al. 1987; Richards et al. 1988; Barratt-Boyes and MacLachlan 1995). Immune precipitation and immunoblotting studies have failed to identify virus-protein specific humoral immune responses that coincide with virus clearance (MacLachlan et al. 1987; Richards et al. 1988). Similarly, interferon production and virus-specific cellular immune responses are temporally unrelated to virus clearance (MacLachlan and Thompson 1985; Ellis et al. 1990). It has been well established that BLU is intimately associated with blood cells throughout viraemia and, logically, it must be this cellular association, and not antigenic drift in the virus nor an inadequate host response, which prevents rapid virus clearance (Luedke 1970; Heidner et al. 1988; Whetter et al. 1989; Barratt-Boyes and MacLachlan 1994, 1995; Katz et al. 1994; MacLachlan et al. 1990a, 1994).

Although viraemia in infected cattle is prolonged up to 50 days or even longer the duration of viraemia is finite, such that truly persistent infections do not occur (MacLachlan et al. 1990b). Once virus has been cleared from the circulation, animals show solid resistance to reinfection with the homologous BLU serotype, although fully susceptible to infection with other serotypes. For instance, Owen et al. (1965) noted that South African cattle that were infected with up to three different BLU serotypes in one year could be infected in the subsequent year with up to three additional serotypes. Given the prolonged viraemia that often occurs in infected cattle, in South Africa Du Toit (1962) and Nevill (1971) hypothesised, very plausibly, that BLU might maintain itself in an area during the coldest times of the year by means of a low level cycle of infection of cattle and insects. However,

clearly the viraemia is not of sufficient duration to facilitate maintenance of virus in the long-term absence of any vector. Thus there is still uncertainty about the source of the BLU strains that reappear annually in parts of the United States where vectors are not found for extended periods during the winter months. Long distance dissemination by infected vector insects is a logical possibility, but one must also consider the possibility that BLU is vertically transmitted in the insect vector, or that there is an unidentified non-ruminant reservoir host. For example, very recent studies have shown that dogs and various wild carnivore species are susceptible to BLU infection (Akita et al. 1994; Alexander et al. 1994; Wilber et al. 1994) but whether they play a role in the natural cycle of BLU infections is unknown.

While it is obvious from the preceding discussion that infection of blood cells facilitates prolonged viraemia in BLU-infected cattle, the pathogenesis of infection of blood cells is not yet understood fully. Initial BLU replication occurs in the regional lymph node draining the site of virus inoculation, and virus replication initiates a prompt humoral and cellular immune response within the infected node (Barratt-Boyes et al. 1995). After primary viraemia, BLU replication principally occurs in lymphoid tissues of both infected sheep and cattle (Pini 1976; MacLachlan et al. 1990a; Barratt-Boyes and MacLachlan 1994) from which virus is released into the blood, where it associates with circulating blood cells. Virus may be isolated from all blood cells, and even transiently from plasma in the initial stages of infection, whereas late in the course of viraemia BLU is associated consistently with red blood cells (Luedke 1970; Whetter et al. 1989; MacLachlan et al. 1990a; Barratt-Boyes and MacLachlan 1994). Alstad et al. (1977) suggested that BLU infection of ruminant blood cells occurred as a consequence of infection of haematopoietic stem cells in bone marrow, as was earlier proposed for the related Colorado Tick Fever virus (Emmons et al. 1972). More recent studies in calves, however, indicate that infection of blood cells was not a consequence of infection of haematopoietic precursors in bone marrow, because only low titres of virus were present transiently in bone marrow, and infected cells were not demonstrated in bone marrow by immunohistochemical staining for viral antigens (Barratt-Boyes and MacLachlan 1994). The kinetics of BLU infection of blood cells clearly are consistent with infection of circulating cells and not with infection of bone marrow stem cells (MacLachlan et al. 1990a; Barratt-Boyes and MacLachlan 1995). The pathogenesis of infection of circulating blood cells awaits full clarification.

Recently, we have developed an hypothesis for the pathogenesis of BLU infections in cattle (MacLachlan 1994; MacLachlan et al. 1994; Barratt-Boyes and MacLachlan 1995). In this scenario, red blood cells facilitate prolonged viraemia in infected cattle by pro-

tecting circulating virus from the immune system. The red blood cells also facilitate infection of blood-sucking insects which disseminate virus to other ruminant species. We have shown that virus first replicates in lymphoid tissues, probably in mononuclear phagocytic cells (MacLachlan et al. 1990a; Barratt-Boyes et al. 1992, 1995). Then virus is released into the blood stream, and any cell-free virus immediately adsorbs to circulating blood cells, regardless of type. Only a few virus particles, at most, would be expected to associate with a single cell. Virus then replicates in, and subsequently kills, permissive cells such as monocytes or proliferating lymphocytes. Most infected mononuclear cells would be killed. As cell-associated virus can be expected to circulate for the lifespan of the infected cell, so platelets and neutrophils, given their very brief life span measured in hours or days, would be infected only very transiently.

Logically, the critical cell type in maintaining viraemia would appear to be the red blood cell because, unable to support viral replication because of its lack of a nucleus and necessary cellular machinery, it would not be killed after infection. We have observed that BLU will bind to, and penetrate, bovine red blood cells after *in vitro* infection (Brewer and MacLachlan 1992, 1994), and a similar phenomenon probably occurs in infected sheep (Nunamaker et al. 1992). Infection of red blood cells, with internalisation of virus, would allow the virus to circulate in sites inaccessible to neutralising antibody but available to blood-sucking insects, which would digest the infected red blood cell and free any 'passenger' virus. The mononuclear phagocytic system would not be expected to be stimulated to remove such affected red blood cells because of the small numbers of associated virions, possibly in the form of infectious viral cores. However, any phagocytosis by tissue macrophages of infected red blood cells that did occur could result in BLU infection of macrophages, which then would contribute to virus production during the initial viraemia. One assumes that removal of infected red blood cells by mononuclear phagocytic cells in the later stages of viraemia does not result in a secondary round of virus replication because of host humoral and cellular immune responses to the virus.

The approximate 150- to 160-day life span of the red blood cell of adult cattle (Jain 1986) is consistent with our proposed pathogenesis for the prolonged viraemia that may occur in BLU-infected cattle, and is identical to the interval when BLU nucleic acid may be detected in blood by PCR analysis after either natural or experimental BLU infection of cattle (Luedke et al. 1977c; Katz et al. 1994). Thus, although virus replication occurs transiently in tissues of infected cattle, viraemia persists as long as blood cells that harbour the virus continue to circulate. Virus clearance occurs only when the last infected red blood cell is subjected

to phagocytosis because of its senescence. There is no evidence for the longterm persistence of BLU after infection of cattle (MacLachlan et al. 1990a; Barratt-Boyes and MacLachlan 1995). In very recent studies, we have clearly shown that bovine blood containing viral nucleic acid (as determined by PCR analysis) but not infectious virus (as determined by isolation), is not infectious to sheep, nor to vector insects that ingest such blood or are intrathoracically inoculated with it (MacLachlan et al. 1994; Tabachnick et al. 1996). This suggests that cattle whose blood contains BLU nucleic acid, but not infectious virus, are unimportant in the natural cycle of BLU infection.

## Congenital Bluetongue Infection

The significance of BLU infection of the bovine foetus has been a topic of much scientific disagreement, as reviewed by Osburn and MacLachlan (these Proceedings). All recent observations, including studies with the same viruses, have failed to confirm the findings of Luedke et al. (1977a, b, c, 1982) that bovine foetuses infected in early gestation are born persistently or latently infected with BLU. Invariably, both natural and experimental infections of bovine foetuses in early gestation with BLU, and with the closely related epizootic hemorrhagic disease virus (EHD), have led either to foetal death or to cerebral malformation in calves that survived in utero infection (Richards et al. 1971; Barnard and Pienaar 1976; MacLachlan and Osburn 1983; MacLachlan et al. 1985; Roeder et al. 1991). Furthermore, precolostral serum from calves infected early in gestation invariably contained antibodies to the virus with which they were infected. Foetuses infected later in gestation (after gestation day 150) do not develop severe teratogenic defects (Jochim et al. 1974). Finally, it must be stressed that most pregnant cattle naturally or experimentally infected with BLU produce normal, uninfected calves.

Scepticism regarding the role of chronically infected cattle in the epidemiology of BLU infection is encouraged further by observations of natural infections in ruminants. In an extensive study in the western United States, virus isolation was carried out on 8751 blood samples from cattle, with BLU being isolated from 206 samples. Isolation was highly seasonal: virus was never isolated from bloods collected from mid-December through June. These data suggest that it is the presence of suitable vectors that is critical to the survival of BLU in the western United States, rather than vertical transmission of virus from persistently infected cattle (Stott et al. 1985). Similarly, although BLU has caused disease epidemics on the Iberian Peninsula, in Greece, and in the Okanagan Valley of Canada, infection has not become endemic in those areas, as would be predicted if vertical trans-

mission and persistent infection of cattle did occur (Gibbs 1983, 1992; Barratt-Boyes and MacLachlan 1995). As these epidemiological studies have failed to identify chronically infected ruminants, it is obvious that BLU will not persist in an area in the absence of a suitable biological vector. Analysis of BLU isolates from different parts of the world indicates that viruses from each area have distinct topotypes (Gould and Pritchard 1990; de Mattos et al. 1994). This suggests that the viruses in each area are not recent introductions but have evolved in those regions over considerable periods of time. Thus all available evidence indicates that BLU has not been disseminated throughout the world by persistently infected cattle.

In summary, one can no longer accept the once popular contention that truly persistent, immunotolerant BLU infection of cattle could occur as a sequel to infection of the bovine foetus. Furthermore, it is very clear that ruminant germplasm from non-viraemic seropositive and seronegative animals can continue to be moved without risk from areas of the world in which BLU infection occurs to those in which it does not.

## Conclusion

Although the concept of truly persistent infection of cattle has been rejected because of lack of convincing evidence, BLU infection of cattle is likely still to be very significant in the complex epidemiology of natural BLU infection. Infected cattle have prolonged viraemias, in the course of which the infected animals can act as virus-amplifiers and reservoirs from which virus may be transmitted by biting insects to other ruminants. Because the concept of persistent BLU infection in cattle has not been adequately substantiated, restrictions on the movement of ruminants and their germplasm should now be based on our understanding that the duration of viraemia is finite, reflecting the lifespan of red blood cells with which the virus associates, and that recovered animals show solid immunity to reinfection with the homologous serotype. On this basis there appears to be little justification for the trade restrictions that have, at times, been imposed on producers of ruminants and ruminant germplasm in areas of the world in which BLU infection occurs.

## References

- Akita, G.Y., Ianconescu, M., MacLachlan, N.J. and Osburn, B.I. 1994. Emergence of bluetongue disease in dogs associated with a bluetongue virus contaminated vaccine. *Veterinary Record*, 134, 283–284.
- Alexander, K.A., MacLachlan, N.J., Kat, P.W., House, C., O'Brien, S.J., Lerche, N.W., Sawyer, M.M., Frank, L.G., Holekamp, K., Smale, K., McNutt, J.W., Laursen, M.K., Mills, M.G. and Osburn, B.I. 1994. Evidence of natural bluetongue virus infection among African carnivores. *American Journal of Tropical Medicine and Hygiene*, 51, 568–576.
- Alstad, A.D., Burger, D., Frank, F.W., McCain, C.S., Moll, T. and Stauber, E.S. 1977. Localization of bluetongue virus in red blood cells of experimentally infected sheep. *Proceedings of the American Association of Veterinary Laboratory Animal Diagnosticians*, 20, 273–290.
- Barnard, B.J.H. and Pienaar, J.G. 1976. Bluetongue virus as a cause of hydranencephaly in cattle. *Onderstepoort Journal of Veterinary Research*, 43, 155–158.
- Barratt-Boyes, S.M. and MacLachlan, N.J. 1994. Dynamics of viral spread in bluetongue virus infected calves. *Veterinary Microbiology*, 40, 361–371.
- 1995. Pathogenesis of bluetongue virus infection of cattle. *Journal of American Veterinary Medical Association*, 206, 1322–1329.
- Barratt-Boyes, S.M., Rossitto, P.V., Stott, J.L. and MacLachlan, N.J. 1992. Flow cytometric analysis of in vitro bluetongue virus infection of bovine blood mononuclear cells. *Journal of General Virology*, 73, 1953–1960.
- Barratt-Boyes, S.M., Taylor, B.C., Ellis, J.A. and MacLachlan, N.J. 1995. Response of the regional lymph node to bluetongue virus infection. *Veterinary Immunology and Immunopathology*, 45, 73–84.
- Brewer, A.W. and MacLachlan, N.J. 1992. Ultrastructural characterization of the interaction of bluetongue virus with bovine erythrocytes in vitro. *Veterinary Pathology*, 29, 356–359.
- 1994. The pathogenesis of bluetongue virus infection of bovine blood cells in vitro: Ultrastructural characterization. *Archives of Virology*, 136, 287–298.
- de Mattos, C.A., de Mattos, C.C., Osburn, B.I. and MacLachlan, N.J. 1994. Heterogeneity of the L2 gene of field isolates of bluetongue virus serotype 17 from the San Joaquin Valley of California. *Virus Research*, 31, 67–87.
- Du Toit, R.M. 1962. The role played by bovines in the transmission of bluetongue in sheep. *Journal of the South African Veterinary Medical Association*, 33, 483–490.
- Ellis, J.A., Luedke, A.J., Davis, W.C., Wechsler, S.J., Mecham, J.O., Pratt, D.L. and Elliot, J.D. 1990. T lymphocyte subset alterations following bluetongue virus infection in sheep and cattle. *Veterinary Immunology and Immunopathology*, 24, 49–67.
- Emmons, R.W., Oshiro, H.N., Johnson, H.N. and Lennette, E.H. 1972. Intraerythrocytic location of Colorado Tick Fever virus. *Journal of General Virology*, 17, 185–195.
- Erasmus, B.J. 1985. The history of bluetongue. *Progress in Clinical and Biological Research*, 178, 7–12.
- Gibbs, E.P.J. 1983. Epidemiology of orbiviruses bluetongue: towards 2000 and the search for patterns. In: Walton, T.E. and Osburn, B.I., ed., *Bluetongue, African horse sickness and related orbiviruses*. *Proceedings 2nd International Symposium*. CRC Press, Boca Raton, 65–75.
- 1993. Bluetongue An analysis of current problems, with particular reference to importation of ruminants to the United States. *Journal of the American Veterinary Medical Association*, 182, 1190–1194.
- Gould, A.R. and Pritchard, L.I. 1990. Relationships amongst bluetongue viruses revealed by comparisons of capsid and outer coat protein nucleotide sequences. *Virus Research*, 17, 31–52.
- Heidner, H.W., MacLachlan, N.J., Fuller, F.J., Richards, R.G. and Whetter, L.E. 1988. Bluetongue virus genome

- remains stable throughout prolonged infection of cattle. *Journal of General Virology*, 69, 2629–2636.
- Howell, P.G. 1963. Bluetongue. In: *FAO, Emerging diseases of animals*. Rome, FAO Agricultural Studies, 61, 109–153.
- Jain, N.C. 1986. *Veterinary hematology*. Philadelphia, Lea and Febiger, 549p.
- Jochim, M.M., Luedke, A.J. and Chow, T.L. 1974. Bluetongue in cattle: immunogenic responses in calves inoculated in utero and after birth. *American Journal of Veterinary Research*, 35, 517–524.
- Katz, J., Alstad, D., Gustafson, G. and Evermann, J.F. 1994. Diagnostic analysis of the prolonged bluetongue virus RNA presence found in the blood of naturally infected cattle and experimentally infected sheep. *Journal of Veterinary Diagnostic Investigation*, 6, 139–142.
- Luedke, A.J. 1970. Distribution of virus in the blood components during viremia of bluetongue. *Proceedings of the United States Animal Health Association*, 74, 9–21.
- Luedke, A.J., Jochim, M.M. and Barber, T.L. 1982. Serologic and virologic responses of a Hereford bull persistently infected with bluetongue virus for eleven years. *Proceedings of the American Association of Veterinary Laboratory Animal Diagnosticians*, 25, 115–134.
- Luedke, A.J., Jochim, M.M. and Jones, R.H. 1969. Bluetongue in cattle: viremia. *American Journal of Veterinary Research*, 30, 511–516.
- 1977b. Bluetongue in cattle: effects of *Culicoides variipennis*-transmitted bluetongue virus on pregnant heifers and their calves. *American Journal of Veterinary Research*, 38, 1687–1695.
- 1977c. Bluetongue in cattle: effects of vector-transmitted bluetongue virus on calves previously infected in utero. *American Journal of Veterinary Research*, 38, 1697–1700.
- Luedke, A.J., Jones, R.H. and Walton, T.E. 1977a. Overwintering mechanism for bluetongue virus: biological recovery of latent virus from a bovine by bites of *Culicoides variipennis*. *American Journal of Tropical Medicine and Hygiene*, 26, 313–325.
- MacLachlan, N.J. 1994. The pathogenesis and immunology of bluetongue virus infection of ruminants. *Comparative Immunology and Microbiology of Infectious Diseases*, 17, 197–206.
- MacLachlan, N.J., Heidner, H.W. and Fuller, F.J. 1987. Humoral immune response of calves to bluetongue virus infection. *American Journal of Veterinary Research*, 48, 1031–1035.
- MacLachlan, N.J., Jagels, G., Rossitto, P.V., Moore, P.F. and Heidner, H.W. 1990a. The pathogenesis of experimental bluetongue virus infection of calves. *Veterinary Pathology*, 27, 223–229.
- MacLachlan, N.J., Nunamaker, R.A., Katz, J.B., Sawyer, M.M., Akita, G.Y., Osburn, B.I. and Tabachnick, W.J. 1994. Detection of bluetongue virus in the blood of inoculated calves: Comparison of virus isolation, PCR assay and in vitro feeding of *Culicoides variipennis*. *Archives of Virology*, 136, 1–8.
- MacLachlan, N.J. and Osburn, B.I. 1983. Bluetongue virus-induced hydranencephaly in cattle. *Veterinary Pathology*, 20, 563–573.
- MacLachlan, N.J., Osburn, B.I., Ghalib, H.W. and Stott, J.L. 1985. Bluetongue virus-induced encephalopathy in foetal cattle. *Veterinary Pathology*, 22, 415–417.
- MacLachlan, N.J., Osburn, B.I. and Stott, J.L. 1990b. Is bluetongue virus infection of cattle a truly persistent viral infection? *Proceedings of the United States Animal Health Association*, 94, 89–98.
- MacLachlan, N.J. and Thompson, J. 1985. Bluetongue virus-induced interferon in cattle. *American Journal of Veterinary Research*, 46, 1238–1241.
- Nevill, E.M. 1971. Cattle and *Culicoides* biting midges as possible overwintering hosts of bluetongue virus. *Onderstepoort Journal of Veterinary Research*, 38, 65–72.
- Nunamaker, R.A., Ellis, J.A., Wigington, J.G. and MacLachlan, N.J. 1992. The intracellular detection of bluetongue virus particles within ovine erythrocytes. *Comparative Biochemistry and Physiology*, 101A, 471–476.
- Osburn, B.I., McGowan, B., Heron, B., Loomis, E., Bushnell, R., Stott, J.L. and Utterback, W. 1981. Epizootiologic study of bluetongue: virologic and serologic results. *American Journal of Veterinary Research*, 42, 884–887.
- Owen, N.C., Du Toit, R.M. and Howell, P.G. 1965. Bluetongue in cattle: typing of viruses isolated from cattle exposed to natural infections. *Onderstepoort Journal of Veterinary Research*, 32, 3–6.
- Ozawa, Y. 1984. Bluetongue and related orbiviruses: Overview of the world situation. *Progress in Clinical and Biological Research*, 178, 13–20.
- Pini, A. 1976. A study of the pathogenesis of bluetongue: replication of the virus in the organs of infected sheep. *Onderstepoort Journal of Veterinary Research*, 43, 159–164.
- Richards, W.P.C., Crenshaw, G.L. and Bushnell, R.B. 1971. Hydranencephaly of calves associated with natural bluetongue virus infection. *Cornell Veterinarian*, 61, 336–348.
- Richards, R.G., MacLachlan, N.J., Heidner, H.W. and Fuller, F.J. 1988. Comparison of virologic and serologic responses of lambs and calves infected with bluetongue virus serotype 10. *Veterinary Microbiology*, 18, 233–242.
- Roberts, D.H., Lucas, M.H. and Bell, R.A. 1993. Animal and animal product importation and the assessment of risk from bluetongue and other ruminant orbiviruses. *British Veterinary Journal*, 149, 87–99.
- Roeder, P.L., Taylor, W.P., Roberts, D.H., Wood, L., Jeggo, M.H., Gard, G.P., Corteyn, M. and Graham, S. 1991. Failure to establish congenital bluetongue virus infection by infecting cows in early pregnancy. *Veterinary Record*, 128, 301–304.
- Spreull, J. 1905. Malarial catarrhal fever (bluetongue) of sheep in South Africa. *Journal of Comparative Pathology and Therapeutics*, 18, 321–337.
- Stott, J.L., Osburn, B.I., Bushnell, R.B., Loomis, E.C. and Squire, K.R.E. 1985. Epizootiological study of bluetongue virus infection in California livestock: an overview. *Progress in Clinical and Biological Research*, 178, 571–582.
- Tabachnick, W.J., MacLachlan, N.J., Thompson, L.H., Hunt, G.J. and Patton, J.F. 1996. Susceptibility of *Culicoides variipennis* to infection by PCR detectable bluetongue virus in calf blood. *American Journal of Tropical Medicine and Hygiene*.
- Whetter, L.E., MacLachlan, N.J., Gebhard, D.H., Heidner, H.W. and Moore, P.F. 1989. Bluetongue virus infection of bovine monocytes. *Journal of General Virology*, 70, 1663–1676.
- Wilber, L.A., Evermann, J.F., Levings, R.L. 1994. Abortion and death in pregnant bitches associated with a canine vaccine contaminated with bluetongue virus. *Journal of American Veterinary Medical Association* 204, 1762–1765.

# Evidence Against Congenital Bluetongue Virus Infection of Cattle and Virus in Semen

B.I. Osburn and N.J. MacLachlan\*

BLUETONGUE virus (BLU) infection of cattle is common throughout tropical and temperate areas of the world. Cattle are most commonly infected by the biting *Culicoides* midges. However, there have also been reports of vertical transmission to the developing foetal calf or, through virus infected semen, to susceptible cows. Congenital infections have led to speculation that infection of immunologically immature foetal calves may lead to immunological tolerance and persistent viraemias.

## Immune tolerance and persistent infection

Experiments were designed to determine if immunological tolerance and persistent viraemias occur in cattle. Calves received intrafoetal inoculation of the US strains of BLU10 or BLU11 UC2 or UC8 (which were laboratory adapted) at either 120–125 or 243 days of gestation. The calves were observed 12 and 20 days following inoculation, and/or at birth, for signs of infection, for antibodies in precolostral serum and for physical deformities. Among the group inoculated at 120–125 days of gestation were calves which could not walk, with severe hydranencephaly and precolostral sera showing antibodies to BLU virus. No virus was recovered from the tissues or

blood of any calf at birth. In the calves inoculated at 243 days of gestation, those infected with UC8 were delivered prematurely, and birth weights were low. The UC2-infected calves were born on the expected parturition dates and were normal in appearance. Brain lesions were minimal and consisted of glial nodules. All calves seroconverted, as precolostral antibodies were present. One of the calves that had been infected for 36 days had cleared virus. These studies showed that transplacental infection with laboratory-adapted bluetongue virus can cause infection of the foetal calf. Whether there are foetal malformations or whether normal calves are born depends on the stage of gestation at which infection occurs. All the foetal calves had seroconverted, indicating that neither immune tolerance nor viral persistence occurs in congenitally infected calves.

## Virus in semen

Fifty seropositive bulls from artificial insemination units were studied to determine if they shed bluetongue virus in semen. No virus was recovered from the semen of any bulls. Studies on seropositive bulls indicate that virus shedding in semen is rare, and it did not occur in this group of bulls.

---

\* Department of Pathology, Microbiology and Immunology, School of Veterinary Medicine, University of California, Davis, California 95616, USA.

# Characteristics of Naturally-occurring Bluetongue Viral Infections of Cattle

L.F. Melville\*, R. Weir\*, M. Harmsen\*, S. Walsh\*,  
N.T. Hunt\* and P.W. Daniels<sup>†</sup>

## Abstract

For 15 years, herds of cattle have been used as sentinels to detect the presence of bluetongue virus (BLU) in the northern part of Australia's Northern Territory during the active season for the principal *Culicoides* vector species. Blood samples have been taken from 848 sentinel cows, steers and bulls weekly or twice weekly. The blood has been cultured for bluetongue and other viruses. Semen from exposed bulls has also been tested for virus throughout the monitoring period, and calves born from exposed cows have been examined pre-suckling by virus isolation and serological techniques. All eight BLU serotypes found in Australia have been represented in the sampling results, although there have been no predictable patterns in the serotypes which are active each year or in the number of sentinel cattle infected. Different BLU serotypes varied in the duration of the viraemia they caused, with most (99.5%) viraemic periods lasting from less than 2 weeks to 2 months. In these natural infections, possible BLU contamination of the semen was observed only once, and there was no evidence of BLU infection of 79 calves which were *in utero* when their mothers were naturally infected.

KNOWLEDGE of the characteristics of viral infections can come from observations of either natural or experimental infections. Data on natural infections are often imprecise: the time of initial infection is unknown, as may be the infection's duration and other aspects, depending on the observer's ability to access and monitor infected animals. Studies of the pathogenesis of viral infections, and the subsequent immune response, therefore frequently rely on experimental infections using viruses isolated in culture systems.

In the case of bluetongue virus (BLU), experience has shown that viruses passaged in cell cultures have markedly reduced pathogenicity in sheep (Gard 1987). Conversely, virus strains attenuated in cell culture have been found to cross the placenta of sheep and cause foetal malformations (Parsonson 1992). Thus information derived from experimental infections cannot be used as a guide to the characteristics of natural infections.

## Old Controversies Regarding Bluetongue Infections of Cattle, Now Mostly Resolved

As research in South Africa showed that cattle in bluetongue epidemic areas have a high prevalence of infection without showing disease (Du Toit 1962), cattle are considered asymptomatic reservoir hosts in that country (Erasmus 1975).

However, there has been considerable confusion over whether BLU causes disease in cattle. As shown in the review by Hourrigan and Klingsporn (1975), clinical signs have been reported in cattle from which BLU has been isolated, and abortions and foetal malformations have been attributed to these infections. However, subsequent analysis of such reports has suggested problems of misdiagnosis (Du Toit 1962; MacLachlan et al. 1992). Bluetongue infections are now no longer considered to cause overt clinical disease in cattle, although infection during early pregnancy may possibly, but rarely, cause reproductive wastage (MacLachlan et al. 1992).

Another issue addressed at length by researchers is whether bluetongue viruses are excreted in bovine semen. Such a possibility has implications for the reg-

\* Department of Primary Industry and Fisheries, Berrimah Agricultural Research Centre, PO Box 79, Berrimah, Darwin, Northern Territory 0828, Australia.

<sup>†</sup> CSIRO Australian Animal Health Laboratory, PO Bag 24, Geelong, Victoria 3220, Australia.



ulation of trade in germplasm. Most concern has resulted from a report that one bull was persistently infected and shed virus for prolonged periods in its semen. This possibility has been substantially refuted (MacLachlan et al. 1992), and it is now considered that bluetongue viruses may be found in bull semen only rarely, and even then only during the viraemic period.

### The Monitoring of Sentinel Animals

The sentinel herd system has been described elsewhere by Daniels et al. and Melville et al. in these Proceedings. At Coastal Plains Research Station (CPRS), near Darwin in Australia's Northern Territory, the experience developed over many years has shown that arboviral infections of livestock are common and that known BLU vectors are present all year round. Hence CPRS is an ideal site for monitoring the incidence of natural BLU infections, and also for conducting experimental work to determine the specific effects of these infections. Bluetongue vaccines have not been used in Australia, nor has their use been reported in neighbouring countries. Bluetongue isolates at CPRS should therefore be wild type viruses, without the incorporation of genetic material from vaccine strains.

In addition to the monitoring each year of the incidence of infections of various BLU serotypes in sentinel steers, observations have also been made on bulls and pregnant cows. Since 1984, bulls have been monitored for BLU presence in semen during episodes of natural infection. During the periods of maximum BLU activity January to May/June each year semen and venous blood samples have been collected and inoculated intravenously into indicator sheep (two per sample), and the sheep monitored serologically for evidence of infection. This system has been suggested as the preferred and most sensitive isolation system for BLU in semen (Parsonson et al. 1981).

Since 1984, cows have been mated during the season of maximum BLU activity and monitored by virus isolation weekly and pregnancy testing monthly. The cows have then been closely supervised at calving so as to allow collection of a colostrum-free serum sample from calves before the first suckling. This has provided data on the natural infections in cows during gestation, and on any reproductive failures or calf deformities, as well as serological data on any intra-uterine viral infections.

### Incidence of Natural Infections

Gard and Melville (1992) presented data on the incidence of natural BLU infections in sentinel steers that occurred at CPRS from 1981 to 1990. This paper adds data for the period 1991 to 1995, and extends previous data by additional observations in other livestock monitored at CPRS during the relevant periods (Table 1).

**Table 1.** Natural bluetongue virus (BLU) infections of sentinel cattle at Coastal Plains Research Station, Northern Territory, Australia 1981-1995.

Year	No. of cattle monitored	No. of cattle infected							
		BLU serotype							
		1	3	9	15	16	20	21	23
1981	86	1							3
1982	70				1			7	5
1983	60	1						1	
1984	45	21			1			8	
1985	46			3					1
1986	46	17	4	1	1	8			
1987	46		22						
1988	46	21				39			
1989	52	2	34						36
1990	52	No bluetongue infections occurred this year							
1991	51		6						
1992	65					47	2		
1993	65	26							
1994	60	40							6
1995	58						41	54	

During the 15-year period, all eight of the BLU serotypes known in Australia (Gard and Melville 1992) were isolated from sentinel cattle at CPRS. The sentinel herds were subject to 31 cycles of BLU infections, during which 460 infections occurred among the 848 cattle being monitored. The most commonly observed BLU serotype was BLU1 (Table 1), which was present during eight of the 15 years. Infections with other serotypes occurred less frequently, in no discernible pattern.

BLU21 was present each year from 1981 to 1984, then not observed again until 1994. BLU9 and 20 infections were observed only twice, while BLU15, 16 and 23 have been observed only three times during the 15-year period. As they are detected irregularly, where are these viruses maintained in the intervening years?

In all 15 years except 1987, 1990, 1991 and 1993, more than one serotype infected the observed animals. In 1990, no BLU viruses were isolated at all, while in 1986 five different serotypes were encountered. In seven specific years, two serotypes were active, while in three years three serotypes were isolated.

The incidence of infection with each serotype varied markedly. During the 15 years, 31 cycles of infection occurred (as evidenced by the isolation of a serotype in any year). In eight of these infection cycles, only one isolate was made of the active serotype. However, these isolations occurred from 1981 to



1986, after which the isolation system was changed to include prepassaging of samples intravenously in embryonated hen eggs followed by passage in mosquito cell cultures (C6/36) before inoculation into BHK21 cultures. Use of this three-stage isolation system has greatly enhanced the efficiency of isolation (Gard et al. 1988). Nevertheless, even in recent years there has been great variability in the recovery rate of viruses. For example, in 1995 BLU21 was isolated from 54/58 cattle, while in 1992 BLU20 was isolated from only 2/65. Serological monitoring of exposures showed that only those two animals had been exposed to BLU20 that year. The isolation system in current use thus appears to be quite sensitive.

The overall picture that emerges is of eight BLU serotypes circulating unpredictably in the geographical location, sometimes in a large wave of infection involving most animals and sometimes infecting only a few animals. The data suggest a threshold of sensitivity for the detection of infections by sentinel animals, with sentinel group size as a factor in the detection of infections. When not being spread by waves of infection, a BLU serotype may perhaps be maintained in the environment by slow spread from one animal to another.

### Duration of Viraemia in Natural Bluetongue Infections of Cattle

The period of detectable viraemia is important epidemiologically, as it is during this time that an infected animal is infective to vectors, and hence potentially active in supporting a cycle of infection. The movement of animals during the viraemic period may move virus to a new location, and may initiate a new cycle of infection there if competent vectors and susceptible mammalian hosts are present. Fortunately, the period of BLU viraemia is relatively short, as BLU does not establish persistent infections (MacLachlan et al. 1992).

Viraemia has been observed in 31 cycles of natural BLU infections involving eight serotypes over a period of 15 years at CPRS (Table 2). As the data are based on weekly virus isolations, an isolate recovered from an animal at only one sampling has been considered to indicate viraemia of less than 2 weeks duration.

Some serotypes have been associated with quite short viraemic periods while others have shown longer durations, with most infected animals having had detectable viraemias lasting less than 2 weeks (Table 2). BLU15 and 9 were isolated for only one and two weeks respectively, while BLU1 and 16 often caused viraemia lasting up to 8 weeks. The least frequently isolated serotypes (Table 1) had the shortest periods of viraemia.

**Table 2.** Duration of detectable viraemia in natural BLU infections in cattle, Coastal Plains Research Station, Northern Territory, Australia, 1981-1995.

BLU serotype	No. of cattle showing viraemia (weeks)								
	<2*	<3	<4	<5	<6	<7	<8	<10	<13
1	52	37	26	7	4	2	1		
3	22	17	16	5	5	1			
9	3	1							
15	3								
16	13	21	26	18	12	1	2		1
20	24	14	3	2					
21	23	21	27	8					
23	19	10	8	5					

\*viraemia of less than two weeks duration.

Only one animal, a bull, had a period of viraemia lasting more than 10 weeks, although the data were equivocal. In most animals throughout the period of detected viraemia, virus was isolated at each sampling during the period, although occasionally not being detected at a weekly sampling. In the case of bull no. 23, with a BLU16 infection in 1988, virus was isolated on 29 February, 3 March and 7 March. There was a single isolation on 11 April and two further isolations on 28 April and 15 May. Hence in this bull, BLU16 was detected intermittently over a period of 67 days, during which time BLU1 was also isolated (on 18 and 21 April) from the animal.

Overall, the data confirm that persistent or prolonged viraemia is not a feature of natural BLU infections, and that the viruses are usually cleared from the circulation within periods ranging from less than two weeks to two months.

### No Evidence for Congenital Bluetongue Infections of Calves of Sentinel Cows

Observations were made of pregnant cattle exposed to natural BLU infections (Table 3): data for the period 1984 to 1989 have been presented previously (Melville and Gard 1992). Available data includes the number of BLU infections in monitored cows; the number of calves born from such cattle from which a pre-suckling serum sample was obtained, and the number of calves from which a blood sample was tested by virus isolation (Table 3).

In some years, very few cows were infected and these did not become pregnant, so these years are not represented in the data. In other years, some cows were infected with two serotypes at different times. For these animals there were two periods during

which bluetongue viruses could have crossed the placenta. Table 3 therefore shows the number of BLU infections observed in cows rather than the number of cattle infected.

In this study of natural BLU infections, no calf of a cow infected during pregnancy was viraemic at birth, nor were homologous antibodies detected in any calf sampled before the ingestion of colostrum. Although abortions and dummy calves were observed in some years, there was no evidence that BLU infection was responsible in these cases (Melville and Gard 1992). There was also no evidence in these studies for transplacental BLU infection of the bovine foetus.

Some comparative published reports suggest that BLU infections in pregnant cows can cause abortions or birth of 'dummy' calves. These reports are based on several types of observations. In the most artificial experimental situation, direct inoculation of foetuses with viruses adapted to cell culture has resulted in cases of hydranencephaly, in both South Africa and North America (Barnard and Pienaar 1976; MacLachlan et al. 1985; Thomas et al. 1986). In other experiments, where pregnant cows rather than foetuses were inoculated with cell culture-adapted BLU, no foetal pathology or evidence of foetal infection was found (Parsonson et al. 1987; Roeder et al. 1991).

However, naturally-occurring intra-uterine BLU infection of hydranencephalic calves has been indicated in California by the detection of BLU antibodies in pre-suckling (pre-colostral) sera from two such cases (McKercher et al. 1970). No reports of equivalent precise observations on cases of teratogenicity in cattle in South Africa are known to the authors, but hydranencephaly in calves has been reported as a recognised problem (Zumpt et al. 1978). Serological data from affected calves pre-suckling were not reported, but serology in calves and dams indicated BLU and Akabane virus infections of the sampled

animals. The clinical syndromes described did resemble those reported after BLU inoculation of bovine foetuses (Barnard and Pienaar 1976; MacLachlan et al. 1985).

Epidemiological observations by MacLachlan et al. (1985, 1992) have suggested that, under natural conditions, abortions and foetal malformations do not have an appreciably greater incidence where BLU infections are active. At CPRS such occurrences have not been attributed to BLU infections (Melville and Gard 1992).

However, the other evidence summarised above does suggest that hydranencephaly is a possible outcome of intra-uterine BLU infections. It would be useful to establish the conditions under which this could occur. In sheep, cell culture-adapted viruses, but not wild strains, have crossed the placenta and been associated with teratogenicity (Parsonson 1992). There arises the question whether cell culture-adapted viruses, such as vaccine strains, may have a similar effect in cattle and if such strains have been circulating in nature in North America (Osburn et al. these Proceedings) and South Africa, as a possible explanation of the BLU-associated cases of hydranencephaly reported in those countries. Such considerations relevant to cattle may have implications for other countries contemplating the use of live attenuated vaccines.

### Non-excretion of Bluetongue Viruses in the Semen of Naturally-infected Bulls

From 1984 to 1995, bulls were studied each year at CPRS to detect any BLU in semen (Table 4), as well as to record viraemias for each of the eight serotypes circulating through the sentinel groups during that period (Table 1). Data for the period 1984 to 1988 have been presented previously (Gard et al. 1989).

**Table 3.** Observations on calves born of cows naturally infected with bluetongue virus (BLU) during gestation, Coastal Plains Research Station, Northern Territory, Australia, 1984-1994.

Year	No. of BLU infections in pregnant cows	No. of possible foetal exposures possibly producing antibodies in pre-suckling calves	No. of calves viraemic at birth/no. of naturally-infected cows
1984*	12	4	not tested
1988	23	10	0/9
1989	33	30	0/19
1991	2	1	0/1
1992	28	13	0/19
1993	12	5	0/8
1994	22	18	0/23

\*Animals located at Berrimah Agricultural Research Centre, Darwin.

**Table 4.** Natural bluetongue virus (BLU) infections of bulls, Coastal Plains Research Station, Northern Territory, Australia, 1984–1995.

Year	No. of bulls	No. infected BLU serotype							
		1	3	9	15	16	20	21	23
1984	5	4							1
1985	6								
1986	6								
1987	6		2						
1988	6	3			6				
1989	7		6						7
1990 <sup>a</sup>	7								
1991	12		1						
1992	12				12	1			
1993	12	10							
1994	8	5							
1995	9						4	7	
Total		22	9		18	5	8	7	

<sup>a</sup> No blue tongue infections occurred at this station (Table 1).

During these observations of natural infections, BLU was detected only once in the semen of a bull, and this occurred while the bull was viraemic, not at any other time. In 1984, Gard et al. (1989) observed a seroconversion to BLU21 in a sheep inoculated with semen from a bull that had also seroconverted to that virus. As seroconversion occurred in only one of two sheep inoculated with the semen, the authors were uncertain whether the observation was due to infected semen or due to insect transmission of virus. However, because the failure of sheep to respond to inocula of BLU21 in infected blood has been observed subsequently (Melville unpublished data), the observation of seroconversion in the sheep inoculated with potentially-infected semen should not be discounted.

Excretion of BLU in semen from naturally-infected bulls must be considered a rare event since only one possible transmission of infection was observed from 69 separate natural infections (Table 1). However, experimental studies (Melville and Kirkland 1995) have resulted in excretion of BLU in semen, detected by sheep inoculation as used in the present studies. Such experiments have shown that excretion of viruses is more likely in older rather than younger bulls, occurs only during the period of viraemia, and more frequently has involved cell cultured rather than wild virus (although in one experiment BLU23 unpassaged in cell culture was detected in semen from aged bulls). Detection of virus in semen is invariably associated with the presence of blood in

the semen (Melville, pers. comm.). These factors should be remembered when interpreting older reports in the scientific literature.

## Discussion

The monitoring of sentinel cattle for BLU infections over a 15-year period has provided an invaluable opportunity of observing the real events associated with natural infections, illustrating again the benefits of a well-designed, prospective approach rather than trying to interpret retrospective observations.

Thirty-one cycles of infection in the sentinel cattle herds resulted in 460 BLU infections among the cattle (Tables 1 and 3). Among these, 459 periods of viraemia were clearly of less than two months duration, while the one equivocal observation suggested a viraemia lasting less than three months. There was no evidence of infection in 79 calves born to cows infected with BLU during the gestation period.

The data from 460 infections of cattle, 79 calves from naturally-infected dams and examination of the semen of 62 infected bulls show that none of these natural infections resulted in persistent infections that could lead to persistent shedding of BLU in semen, or that could offer a means of maintaining BLU in the local environment. The changes in serotypes active from year to year (Table 1), and the irregularity with which they were manifest, also suggest that the blue-tongue viruses that were isolated were not maintained in the district by persistently infected animals. The pattern was rather one of the local circulation of viruses introduced from other foci of infection.

These observations of natural infections add further evidence to refute earlier hypotheses of BLU epidemiology. There is no evidence that natural infections with wild BLU strains result in the clinical disease of cattle, nor that such infections are associated with infection of the foetus or reproductive wastage. There is evidence that excretion of wild BLU in the semen of infected bulls is a rare event, and associated only with the period of viraemia. All 460 infections, observed in a range of male and female stock of varying ages, were self-limiting.

## References

- Barnard, B.J.H. and Pienaar, J.G. 1976. Bluetongue virus as a cause of hydranencephaly of cattle. *Onderstepoort Journal of Veterinary Science*, 43, 155–157.
- Du Toit, R.M. 1962. The role played by bovines in the transmission of bluetongue in sheep. *Journal of the South African Veterinary Medical Association*, 33, 483–490.
- Erasmus, B.J. 1975. The epizootiology of bluetongue: the African situation. *Australian Veterinary Journal*, 51, 196–198.

- Gard, G.P. 1987. Studies of Bluetongue Virulence and Pathogenesis in Sheep. Technical Bulletin No. 103, Department of Industries and Development, Darwin, 58 p.
- Gard, G.P. and Melville, L.F. 1992. Results of a decade's monitoring for orbiviruses in sentinel cattle pastured in an area of regular arbovirus activity in northern Australia. In: Walton, T.E. and Osburn, B.I., ed., Bluetongue, African horse sickness and related orbiviruses. Proceedings 2nd International Symposium. CRC Press, Boca Raton, 85-89.
- Gard, G.P., Melville, L.F. and Shorthose, J.E. 1989. Investigations of bluetongue and other arboviruses in the blood and semen of naturally infected bulls. *Veterinary Microbiology*, 20, 315-322.
- Gard, G.P., Weir, R.P. and Walsh, S.J. 1988. Arboviruses recovered from sentinel cattle using several virus isolation methods. *Veterinary Microbiology*, 18, 119-125.
- Hourigan, J.L. and Klingsporn, A.L. 1975. Epizootiology of bluetongue: the situation in the United States of America. *Australian Veterinary Journal*, 51, 203-208.
- Maclachlan, N.J., Barratt-Boyes, S.M., Brewer, A.W. and Stott, J.L. 1992. Bluetongue virus infections of cattle. In: Walton, T.E. and Osburn, B.I., ed., Bluetongue, African horse sickness and related orbiviruses. Proceedings 2nd International Symposium. CRC Press, Boca Raton, 725-736.
- MacLachlan, N.J., Osburn, B.I., Stott, J.L. and Chalib, H.W. 1985. Orbivirus infection of the bovine fetus. In: Barber, T.C., Jochim, M.S. and Osburn, B.I. ed., Bluetongue and related orbiviruses. Progress in Clinical and Biological Research, vol. 178, Alan R. Liss Inc, New York, 79-84.
- McKercher, D.G., Saito, J.K. and Singh, K.V. 1970. Serologic evidence of an etiological role for bluetongue virus in hydranencephaly of calves. *Journal of the American Veterinary Medical Association*, 156, 1044-1047.
- Melville, L.F. and Gard, G.P. 1992. Investigations of the effects of natural infection with orbiviruses on reproduction in cattle. In: Walton, T.E. and Osburn, B.I., ed., Bluetongue, African horse sickness and related orbiviruses. Proceedings 2nd International Symposium. CRC Press, Boca Raton, 744-750.
- Melville, L.F. and Kirkland, P. 1995. Evaluation of bluetongue virus excretion in the germplasm of cattle. Final Report Project NTA 018, Northern Territory Department of Primary Industry and Fisheries, Berrimah, 20 p.
- Parsonson, I.M. 1992. Overview of bluetongue virus infection of sheep. In: Walton, T.E. and Osburn, B.I., ed., Bluetongue, African horse sickness and related orbiviruses. Proceedings 2nd International Symposium. CRC Press, Boca Raton, 713-724.
- Parsonson, I.M., Della-Porta, A.J., McPhee, D.A., Cybinski, D.H., Squire, K.R.E., Standfast, H.A. and Uren, M.F. 1981. Isolation of bluetongue virus serotype 20 from the semen of an experimentally-infected bull. *Australian Veterinary Journal*, 57, 252-253.
- Parsonson, I.M., Della-Porta, A.J., McPhee, D.A., Cybinski, D.H., Squire, K.R.F. and Uren, M.F. 1987. Bluetongue virus serotype 20: experimental infection of pregnant heifers. *Australian Veterinary Journal*, 64, 14-17.
- Roeder, P.L., Taylor, W.P., Roberts, D.H., Wood, L., Jeggo, M.H., Gard, G.P., Corteyn, M. and Graham, S. 1991. Failure to establish congenital bluetongue infection by infecting cows in early pregnancy. *Veterinary Record*, 128, 301-304.
- Thomas, F.C., Randall, G.C.B. and Myers, D.J. 1986. Attempts to establish congenital bluetongue infection in calves. *Canadian Journal of Veterinary Research*, 50, 280-281.
- Zumpt, G.F., Bryson, R.W. and Andreou, S. 1978. Hydranencephaly in calves in the Natal region. *Journal of the South African Veterinary Medical Association*, 49, 32.

# Diagnostic Techniques for Bluetongue Viruses

P.D. Kirkland\* and T.D. St. George†

## The Biology of Bluetongue Virus Infections

Our current knowledge of livestock infections with bluetongue viruses has improved significantly with the introduction of modern technology, and with a better appreciation of issues that affect the reproducibility and quality control for diagnostic tests. In particular, we now have a more informed understanding of the interactions between bluetongue virus and different animal species; of animals' responses to infection; and of the persistence of virus in nature. These issues are extremely important for disease control and for the safe movement of animals between regions and countries.

The length of time during which a bluetongue virus is present in the blood, and during which antibodies are produced and persist, will vary, especially between cattle and sheep. In the early stages of bluetongue infection, up to the sixth or seventh day after an animal has been bitten by an insect, virus is only present in the bloodstream (ie. the animal has viraemia). The level of virus in the blood reaches a peak at about seven to ten days after infection and this may coincide with a fever. In some animals, antibodies to the virus first appear at about this time. However, the ability to detect antibodies in the early stages of infection depends on the type of test and the type of antigen to which the antibodies respond after the first week of infection. Viable virus and antibodies co-exist in the bloodstream for a variable number of weeks, usually not more than about three to four weeks in sheep and four to eight weeks in cattle. Virus fragments, especially RNA, may be found in

blood samples for much longer periods, as shown by polymerase chain reaction (PCR) testing. However, we do not believe these fragments are able to infect insects or animals. After the virus is completely gone, antibodies remain in the bloodstream, perhaps for a year and sometimes for life. The measured length of these antibody periods depend on the species of animal, the possibility of further infections with related viruses, and the type of test used.

Diagnostic tests can be directed towards the virus; towards group antibody (antibodies common to all bluetongue viruses); or towards serotype-specific antibody (antibodies directed against the antigens unique to viruses of a particular serotype).

## Tests for Virus, Antigen and Nucleic Acid

Compared to tests for antibody, most tests to detect bluetongue virus, antigen or nucleic acid take longer to obtain results or are more expensive. However, these techniques may be the only option during the very early stages of infection.

## Animal inoculation

Animal (especially sheep) inoculation has often been used as a standard for the detection of viable bluetongue virus and generally has high sensitivity. This approach, which depends on the availability of susceptible animals, is usually expensive and is not suitable for processing large numbers of specimens. The method allows the inoculation of a large volume of specimen. Confirmation of the presence of bluetongue depends on serology, so a final result may not be available for up to four weeks after inoculation. Blood from viraemic animals from a natural transmission can be a valuable source of 'wild' virus (ie. virus that has never been passaged through cell culture, or mice or chicken embryos) for pathogenicity studies.

\* Virology Laboratory, Elizabeth MacArthur Agricultural Institute, PMB 8, Camden, New South Wales 2570, Australia.

† 15 Tamarix Street, Chapel Hill, Queensland 4069, Australia.

## Virus isolation

Virus isolation generally involves the inoculation of chicken embryos and/or cell cultures. One method uses intravenous inoculation of embryonated chicken eggs, followed by passage first in mosquito cells and then in BHK21 tissue cultures: this method has a level of sensitivity similar to that of sheep inoculation. The presence of virus in a specimen is detected by the occurrence of cytopathic effects (CPE) in the indicator (usually BHK21) cells, but needs further confirmation by antigen detection methods (including neutralisation with specific antiserum). The advantage of this method is that viable virus is available for typing to current world standards, and its virulence may also be tested by using the source material.

Methods using the direct detection of antigen in chicken embryos are of equal sensitivity and reduce the time for screening for the presence or absence of bluetongue virus. Antigen detection by enzyme linked immunosorbent assay (ELISA) has high sensitivity, but nucleic acid probes, immunostaining and 'dot blot' techniques may also be useful. Direct inoculation of specimens into cell cultures, bypassing the chicken embryo amplification step, usually has a markedly lower sensitivity.

## Antigen and nucleic acid detection

Methods for the direct detection of antigen or nucleic acid in animal tissues have been developed in research projects but generally have a lower sensitivity than virus isolation, and so have not been adapted for routine diagnostic use. Antigen detection ELISA appears to show some promise in this area.

## Polymerase chain reaction

The polymerase chain reaction (PCR) is the newest and most rapid method currently available to confirm early bluetongue infections by detecting viral nucleic acid. The presence of bluetongue virus in blood or tissue specimens can be proven within 36 to 48 hours. Although the technique is generally as sensitive as virus isolation, it is technically difficult, requires staff training, stringent quality control and laboratory discipline, and expensive equipment and reagents. Another disadvantage is that PCR does not distinguish between intact viable virus and RNA fragments. This is particularly important with vector studies, as the virus may be contained within the remains of a blood meal and not infective. Finding bluetongue RNA in an insect does not prove that it is a vector of that virus as the virus may not have multiplied, and residual virus may persist at low levels. The PCR technique may also be used to serotype some bluetongue viruses.

## Tests for Antibodies

The requirements of satisfactory tests for antibodies are that:

- the tests should be sensitive, specific, highly reproducible, able to be standardised and evaluated internationally, and inexpensive; and
- reagents should be readily available, preferably based on non-infectious antigens, and stable after transport over long distances at variable temperatures.

Preferred tests are those that indicate the correct status of an animal soon after infection and over a long period of time. Available tests include complement fixation (CF), agar gel immunodiffusion (AGID), the competitive ELISA (cELISA) and the virus neutralisation (VN) test. The CF, AGID and cELISA tests are bluetongue group tests while the VN test is serotype-specific. The advantages and uses of these tests are as follows:

### Group antibody

The *CF test* is technically complex and frequently has problems with unsuitable or anti-complementary sera. Antibodies may not be detected in this test for a relatively long time after infection (up to 45 days) and antibody is usually short lived (4–12 months). This test also has problems with a lack of specificity and many false positives are detected, especially in cattle or sheep in regions where neither bluetongue nor related viruses exist. The CF test is no longer recommended for bluetongue diagnosis, and is not routinely used in Southeast Asia, being applied only to imported animals.

The *AGID test* is cheap, simple to perform, requires minimal laboratory facilities, and can be used with poor quality sera. It detects antibodies to all viruses in the bluetongue group but, to a variable extent, also detects cross-reacting antibodies to viruses in related orbivirus groups. The reading of test results is subjective so weak positives may be missed. Antibodies develop very early and may be detected from eight days after infection, with animals almost always positive after 14 days. Antibody usually persists for at least one year in cattle after a single infection and longer in sheep. While AGID is not as sensitive as the cELISA, it is very useful for testing sentinel animal sera for the first appearance of antibodies to indicate that virus may be found in a blood sample.

The *cELISA test* uses monoclonal antibodies against a specific component of the bluetongue virion which is common to all bluetongue viruses. As these monoclonal antibodies do not react with other viruses, the cELISA test is bluetongue-specific. It is also more sensitive: antibodies may be detected in some cases from 7 or 8 days after infection and per-

sist for a very long time (perhaps many years). While cELISA is quicker than AGID, it needs specific laboratory equipment: however, as the latter is generally available in most diagnostic laboratories, it allows the test to be semi-automated and eliminates subjectivity during reading. The cELISA has been standardised and evaluated internationally and is the preferred test for bluetongue group antibodies. Kits of test reagents are available commercially.

### **Serotype-specific tests**

*Animal protection tests* are the oldest serotype-specific test. They depend on the availability of susceptible sheep and the ability to reproduce disease under experimental conditions. These tests take more than one month to complete and require specific controls.

*Virus neutralisation tests* are based on the detection of neutralising antibodies, which are usually detected from 8 to 18 days after infection and usually persist for at least one year. Individual tests are

required for each serotype: tests have been developed for all 24 serotypes of bluetongue viruses. The tests depend on cell culture, and require good laboratory facilities and good quality samples. Virus neutralisation tests generally detect antibody that is specific to a particular serotype but there can be cross-reactions between some serotypes. As there are minor variations even in viruses of the same serotype, for optimal results VN tests must be standardised for each country. However, since these tests rely on an active biological system, standardisation is more difficult than for cELISA and AGID and may become more subjective. This means that VN testing should be used for confirmatory and serotyping after the use of a group screening test such as cELISA. Nevertheless, a VN test is especially useful when applied to diagnostic sera and sera from sentinel animals where seroconversion on samples taken two to four weeks apart can identify the serotype: this kind of test is often referred to as a serum neutralisation test.

# Bluetongue—Its Impact on International Trade in Meat and Livestock

G.I. Alexander\*, M.P. Alexander\* and T.D. St. George†

## Abstract

The papers presented in these Proceedings provide strong and growing support for the concept that bluetongue disease is an endemic disease of the tropical regions when it is sustained by an active population of *Culicoides* vectors and suitable mammalian hosts. There are periodic outbreaks of bluetongue adjacent to the tropics. Countries with large populations of Merino sheep and seasonal incursions of competent *Culicoides* vectors appear to be most at risk, although other breeds can become seriously affected on occasion without any apparent reason. These Proceedings also help to clarify the disparities in the pathogenesis of the disease in different countries. These disparities may have been the result of using attenuated viruses in vaccines to control outbreaks of the disease, resulting in transmission of the attenuated vaccine viruses by the *Culicoides* vector with possible reassortment of genes between attenuated and wild viruses. It is clear that the history of viruses used in experimental disease must be well-defined as some of the international sanctions are based on information derived from laboratory altered viruses. These recent advances in the knowledge of bluetongue have provided a sound basis for a reassessment of the protocols applied by many countries against bluetongue. It now seems that the use of restrictive protocols has disadvantaged access to improved ruminant genetic material. It is anticipated that, as the result of disseminating this knowledge and its implications, less restrictive protocols will be developed among countries in the bluetongue zone, especially Australia and her trading partners, to reduce the impact of bluetongue on trade in ruminants and their products. These protocols will recognise regional and seasonal freedom of virus activity, and the limited period of viraemia when the ruminants are infectious and capable of spreading the disease. The protocols could also allow for the increased flexibility and safety that can be achieved by using core-like particles (CLPs) to protect sheep exported to countries where they may be exposed to bluetongue infection.

BLUETONGUE disease is a List A disease as classified by the Office International des Epizooties (OIE). List A diseases are defined as communicable diseases which have the potential for very serious and rapid spread, irrespective of national borders, which are of serious socioeconomic or public health consequence and which are of major importance to the international trade of livestock and livestock products. Member countries of the OIE are obliged to report

these diseases, and trading partner countries are usually strict with regard to regional freedom and health certification. The 15 List A diseases include foot-and-mouth disease, rinderpest, hog cholera and Newcastle disease.

## Why Is Bluetongue a List A Disease?

Bluetongue earned its notoriety based on experience with the disease in Merino sheep in South Africa and USA and, in particular, in an epidemic in Merino sheep in the Iberian Peninsula in 1956. Bluetongue's global epidemiology and effects are well covered in other papers in these Proceedings.

---

\* Palamere, GPO Box 870, Brisbane, Queensland 4001, Australia.

† 15 Tamarix Street, Chapel Hill, Queensland 4069, Australia.



Many of the present trade restrictions were formulated on the basis that some cattle remain persistently infected with bluetongue and act as symptom-free reservoirs for the disease, and that international movement of such cattle or their products, such as semen, could spread the disease. These concerns about the role of cattle as reservoir hosts and possible agents of disease spread have led virus-free countries to restrict or ban the import of ruminants from areas where bluetongue is endemic. Another factor that has fuelled this concern has been the lack of definitive information about bluetongue's epidemiology throughout the world. Some countries where certain serotypes are endemic have also been concerned to restrict imports to prevent the introduction of what they perceive as new, more virulent, serotypes.

### **Bluetongue—an Arbovirus Disease Endemic to the Tropics**

The situation regarding the status of bluetongue disease of sheep is becoming clearer. Bluetongue can no longer be regarded as an emerging virus disease originating from Africa. As bluetongue's causal agent is an arbovirus carried by particular *Culicoides* species, it is dependent for its spread on the distribution and population fluctuations of the competent vectors among the *Culicoides* species that are present. Bluetongue now appears to be endemic in most tropical regions of the globe with periodic incursions into the subtropical and temperate regions in seasonal conditions favourable to its *Culicoides* vectors. The 24 serotypes of the virus are not uniformly distributed even in the endemic areas, and there appears to be a degree of polymorphism in genotype within these serotypes.

In China, clinical bluetongue disease has been diagnosed in six provinces since 1979 and strains of bluetongue virus (BLU) serotypes 1 and 16 have been isolated in six provinces as well as in Xinjiang and Inner Mongolia. On the basis of subsequent studies reported in these Proceedings, it is considered that bluetongue is endemic in the southeastern third of China bounded to the west by Yunnan, Sichuan, Shanxi, Henan, and Shandong Provinces with incursions as far as Inner Mongolia. There is considerable support in the Chinese Provinces for the maintenance of a series of sentinel herds to monitor the widely dispersed outbreaks of bluetongue which have occurred in the country.

In Indonesia, four sentinel herds were used to monitor bluetongue activity in West Java, Bali, Nusa Tenggara Timur and Irian Jaya. The viruses for serotypes BLU1, 3, 7, 9, 12, 16, 21 and 23 have been isolated from the blood of apparently healthy cattle and large ruminants had a higher prevalence of infection

than small ruminants. Since local sheep have not shown any clinical disease, Merino sheep of a susceptible age from Australia were used to demonstrate that clinical signs were mild, indicating that isolates BLU9 and 21 were of low pathogenicity.

In India bluetongue has been recognised as endemic, after an initial outbreak in 1964. While cattle and goats have been seropositive for bluetongue, they have not shown evidence of clinical disease, although the latter has been consistently demonstrated in native and exotic sheep. Serotypes BLU1, 2, 3, 9, 16 and 23 have been identified by virus isolation while antibodies to 11 other serotypes have been recorded.

In Malaysia, bluetongue is endemic with no manifestation of clinical disease in cattle, buffalo, sheep or goats. Sentinel herds set up at four sites throughout Malaysia yielded samples from which six different serotypes were isolated; BLU1, 2, 3, 9, 16 and 23. Pathogenicity studies on Merino  $\times$  Border Leicester sheep using serotypes BLU1, 2, 3, 9 and 23 demonstrated that the sheep had some degree of tolerance or resistance to the disease. It would be interesting to examine the pathogenicity of these viruses with susceptible Merino sheep.

In Thailand and Myanmar, serological testing using the agar gel immunodiffusion (AGID) test has shown that cattle, goats and sheep and group had antibodies to bluetongue. However, there has been no evidence of clinical disease in sheep, goats or cattle. There is no information on the bluetongue situation in Vietnam, Laos, Cambodia and Taiwan.

As the gaps are filled regarding bluetongue in Southeast Asia, the general situation will become clearer, but already there is strong evidence that the disease is endemic in tropical countries. This notion is supported by the knowledge that, with the exception of Indian native sheep, no local sheep display clinical signs of the disease (or, on rare occasions, display only very mild disease). Indeed, it appears that the type of sheep most susceptible to the disease are mature Merinos. Even cross-bred Merinos seem more tolerant of the disease than pure Merinos. This means that pure Merinos are likely to develop severe bluetongue signs when introduced into these endemic areas: cross-bred Merinos would also be at risk, but to a lesser degree.

There is keen interest in other Southeast Asian countries in completing the overall picture of bluetongue infection throughout the region. Vietnam, in particular, needs to establish the incidence of bluetongue in that country. Because of the major climatic and seasonal changes in Vietnam from south to north, research into the epidemiology of the virus and its vectors in that country should provide valuable additional information on bluetongue epidemiology in tropical and subtropical regions.

## Insect Vectors for Bluetongue

To class an insect species as a competent vector of an arbovirus several criteria must be met:

- The insect should be shown to feed on the mammalian host.
- The virus should be shown to be ingested by the insect host, multiply in the insect and not be present in the host adventitiously.
- The insect must be shown to be able to transmit the virus biologically from one mammalian host to another.

Unfortunately, information on vector competence for bluetongue virus among *Culicoides* species is almost non-existent in the Asian-Pacific region, with the exception of Australia and some data from Indonesia and Malaysia.

Using light traps, Indonesian workers established that the vectors of bluetongue known on the basis of Australian experiments (*C. brevitarsis*, *C. actoni*, *C. wadai* and *C. fulvus*) were present in significant numbers at several of their trapping sites. Subsequently BLU21 was isolated from *C. peregrinus* from a mixed sample of *C. fulvus* and *C. orientalis*, and from a sample of *Anopheles* species while BLU1 was isolated from *C. fulvus*.

In Malaysia, on the basis of observed abundance, distribution and host preference, *C. peregrinus*, *C. orientalis* and *C. shortii* may be considered possible vectors for BLU viruses. However, in Australia these three criteria alone have not been found sufficient for defining a competent vector. The main criterion that must be met is the insect's capacity to transmit virus from one mammalian host to another. Further studies need to be carried out in Malaysia to establish the competent vectors there.

More detailed information is needed on the distribution and competence of *Culicoides* as vectors of bluetongue in the Asian-Pacific region and their seasonal fluctuations. Until this is done, there will be only an incomplete understanding of the epidemiology of the disease in the region on which to base risk assessment.

## Pathogenesis of Bluetongue and Its Variability

As explained earlier, the classical pathogenesis of bluetongue has been based on experience with the disease in South Africa and USA and the 1956 outbreak in the Iberian Peninsula.

Papers in these Proceedings challenge these views. Australian research, using field or 'wild' viruses that had not been processed or adapted in the laboratory, showed that serotypes BLU3, 15, 16 and 23 were highly virulent to older Merino sheep, producing

clinical signs equal to those seen in the most severe bluetongue infections and mortality rates from 8%–32%. While infections with these bluetongue serotypes were severe, the disease was short-lived, the virus did not cross the placenta to cause foetal deaths or abnormalities, and virus was not found in semen (except occasionally during viraemia of relatively short duration). While cattle showed no clinical disease symptoms, they did become viraemic, and occasionally bulls excreted virus in semen during viraemia.

In contrast to 'wild' viruses, Australian serotypes attenuated for vaccine experiments have been shown to be teratogenic, in a similar fashion to attenuated South African and North American serotypes, if administered to ewes during the first half of pregnancy. Attenuated virus strains have been transmitted by *Culicoides* vectors. Since BLU viruses readily recombine with each other, it is reasonable to assume that attenuated viruses could recombine with wild type virus to create a new virus with characteristics of both.

US research presented in these Proceedings compared the BLU10 field isolates from 1980–81 and 1990 with prototype BLU2, 10, 11, 13 and 17 and vaccine virus by sequence analysis. This suggests field isolate BLU13 may have been derived in part from a reassortment virus which has a gene segment from the BLU10 vaccine virus. This evidence illustrates the genetic polymorphism of the BLU viruses, since their replication cycle involving insect vectors and mammalian hosts offers opportunities for genetic reassortment and the development of new viruses. It also highlights the risks associated with the use of an attenuated bluetongue vaccine during an active outbreak of bluetongue whereby wild viruses may acquire the undesirable teratogenic characteristics of the attenuated vaccine virus.

Studies in the USA on the virus amplification that occurs before transmission of BLU to *Culicoides* vectors showed that the virus becomes associated with blood cells, resulting in a prolonged viraemia of up to 50 days approximating the infectivity period. Viral nucleic acid can be detected for up to 150 days in cattle and for slightly less time in sheep, a period that approximates the life span of the red blood cell.

## Bluetongue as a Barrier to Trade in Livestock

As described earlier, various concerns about the role of cattle as reservoir hosts for bluetongue and the lack of definitive information about bluetongue epidemiology worldwide have led to trade restrictions among countries.

The accumulated research data indicates that bluetongue virus causes an infection that is variable in severity but discrete in duration: after this time the ruminant is no longer infected although still retains antibodies to bluetongue. The use of attenuated vaccines in some countries has complicated the situation in those countries in terms of the nature of the disease. However, ruminants that show antibody to bluetongue as the result of natural infection or vaccination and are no longer viraemic should not pose a risk of causing an outbreak of the disease when introduced into other areas. Nevertheless, these animals may become infected by the local serotypes of bluetongue. When this does occur, the available evidence suggests that the severity of the subsequent infection is reduced and mortalities prevented.

There is unlikely to be any threat of disease outbreak posed by the international movement of semen and embryos from cattle, sheep or other ruminants which are seropositive to bluetongue but were not viraemic at the time of collection of semen or embryo.

## **Vaccination as a Means of Facilitating International Movement**

### **Attenuated live virus**

Attenuated vaccines have been used extensively in South Africa and the USA with considerable success in controlling clinical outbreaks of the disease. These vaccines are the cheapest to produce and provide a high level of protection although, as discussed earlier, they do have some associated problems. There is no doubt that South African and North American vaccine strains are teratogenic. While the relative level of teratogenicity of attenuated virus from South African and Australian serotypes is the subject of contention, the risk involved in the use of attenuated Australian serotypes has been clearly established in one Australian laboratory. The other factors of genetic recombination and transmission by *Culicoides* species provide further constraints against using attenuated vaccines to control outbreaks.

Nevertheless, such vaccines may be of value in protective vaccination of ruminants for export to countries where bluetongue may be endemic, provided that the vaccination is carried out in the absence of vectors and 150 days before export. Even then, there would always be a risk that the vaccine could be used more widely without precautions taken to prevent infecting vectors. The resultant recombinants with wild strains could then infect *Culicoides* vectors. Overall, therefore, it would wisest not to use attenuated vaccines at all.

### **Inactivated whole virus vaccine**

An inactivated whole virus vaccine is more costly to produce than an attenuated live virus vaccine but has been demonstrated to provide protection against experimental infections with virulent virus. While there may also be some level of protection against challenge with some heterologous serotypes, this has not yet been well documented. The success of inactivated vaccines in China has been described.

### **Virus-like particles (VLPs) vaccines**

VLPs contain the core proteins as well as the outer capsid proteins. As VLPs carry no viral genetic material, they possess the advantage of being non-infectious. VLPs have been shown to immunise sheep: the immunity is generally serotype-specific and confers some heterologous protection.

### **Core-like particles (CLPs)**

CLPs comprise the core proteins of bluetongue virus and are easier to produce than VLPs. In separate South African and Australian experiments, CLPs produced partial immunity in sheep challenge with wild viruses. This partial immunity was not serotype-specific and may be largely cell-mediated. Although further work is necessary to determine the value of CLPs as a vaccine, they may have promise in conferring short-term immunity on animals that are to be imported into countries where bluetongue is endemic. Certainly CLPs could be examined as a means of protecting sheep imported into the southeastern sector of China, which appears to be an endemic zone.

## **Commercial Production of a Vaccine**

A major factor in the production of vaccines against bluetongue has been the commercial aspects of vaccine manufacture. Most manufacturers need a demonstrated market before they are prepared to invest capital and other resources into vaccine production. The situation in South Africa has produced such a market for their cheap attenuated bluetongue vaccines because of the continual threat to their sheep population of the multiple serotypes of bluetongue. However, in many other countries, such as Australia, bluetongue vaccines are seen as a means of containing an outbreak of the disease which may never occur. In such circumstances it is not economic for a manufacturer to develop or produce vaccines. As all vaccines other than the CLPs are serotype-specific, it has been accepted that vaccines would be needed against each serotype. CLPs present an opportunity to produce a vaccine which could have a use in international trade as well as providing a level of protection in the event of an outbreak. CLPs can be used at any time, and can be modified so that vaccinated and

bluetongue-infected sheep can be differentiated by the use of an appropriate ELISA test.

### **Conclusion**

In the Asian-Pacific region almost all countries have endemic bluetongue with multiple serotypes. The

probability is that more serotypes will be found although their individual distributions are presently poorly understood. The current trade sanctions are based on experimental data that is now known to have been inaccurate. The information presented in these Proceedings is a useful basis on which to reassess the rules relating to bluetongue in this region, for mutual benefit, without increasing risk.

# Future Directions in Bluetongue Research

P.D. Kirkland\*

UNTIL very recently, we had very little information on bluetongue viruses in China, but these Proceedings show how the situation has changed. We have had many interesting papers, ranging from studies of disease outbreaks in China and other countries to research involving advanced molecular biology techniques. At the Symposium it was valuable to have discussions involving scientists from so many countries in this Asian-Pacific region. There are many young scientists who now have training in a wide range of bluetongue research methods, so consequently there are many opportunities to make rapid progress in bluetongue research in this region.

However, the starting materials for our projects usually comprise blood and tissue samples from ani-

mals, and subsequently the viruses amplified in the laboratory. In some Asian countries at present, it is difficult to collect a large number of samples from animals. Close cooperation is needed among field veterinarians, farmers, laboratory researchers and government officials to ensure that specimens are readily available in the future. When this happens we are sure to see even more rapid progress in bluetongue research in the Asian-Pacific region. With rapid transport available, collaboration between countries is easier. We have the possibilities of exchanging information and sharing valuable laboratory resources through close collaboration. I look forward to hearing the results of successful studies in the future.

---

\* Virology Laboratory, Elizabeth MacArthur Agricultural Institute, PMB 8, Camden, New South Wales 2570, Australia.

# The First Southeast Asia and Pacific Regional Bluetongue Symposium

## Closing Address

**Zhao Shi Kun\***

LADIES and gentlemen—the First Southeast Asia and Pacific Regional Bluetongue Symposium is about to be closed. I am summarising this Symposium on behalf of Mr Lin Wenlan, the Director of Yunnan Provincial Commission on Science and Technology and the Chairman of the Management Committee of the Yunnan Tropical and Subtropical Animal Virus Disease Laboratory. The 105 delegates at the Symposium have come from Australia, the United States of America, United Kingdom, Vietnam, India, Indonesia, Malaysia, Philippines, Thailand, Papua New Guinea and Japan (11 countries in all) and also from the Department of Animal Industry and Veterinary Medicine, the Department of International Cooperation and Animal Quarantine Institute of Ministry of Agriculture, China, and from 10 provinces (Yunnan, Hubei, Anhui, Inner Mongolia, Xinjiang, Guangxi, Jiangsu, Shanxi and Gansu).

The participants exchanged their experience in the aetiology, epidemiology, diagnostic methods, immunology, control and entomology of bluetongue, and the desired results have been achieved.

- We have a clear understanding of the epidemiology and the distribution of bluetongue in the Asia and Pacific Region.
- There is some progress in the aetiology.
- We note that some gratifying achievements have been made in the area of vaccines and control, especially attenuated vaccines, inactivated vaccines and genetically-engineered vaccines. Of these, some vaccines have been used in the animal industry.

Throughout the Symposium, we have noted great successes in research on bluetongue in Asia and the Pacific region. The success displayed will further

promote research and control of bluetongue and strengthen the connection and academic exchanges among the scientists in this region, so this is a successful Symposium.

This success would not have been possible without the attention and support of Agriculture Ministry, People's Republic of China, the Yunnan Provincial Government, the Australian Centre for International Agricultural Research and the Yunnan Tropical and Subtropical Animal Virus Disease Laboratory working together. The Symposium Committee and the scientific staff of Yunnan Tropical and Subtropical Animal Virus Disease Laboratory have also devoted months to the complex preparation necessary for the success of this Symposium. All the participants here have also taken full advantage of the opportunity for discussions.

The Symposium was held here in the Greenlake Hotel which provided such good services and facilities. This meant that the delegates had more time to exchange experience and to establish friendship with each other outside the formal sessions. This had the two-fold effect of promoting information exchange and friendship.

Science and technology is the wealth shared by human beings. The achievements will be used to serve the people in all the world. I hope the achievements in this Symposium, the knowledge, will also become the wealth shared by us all. The Symposium is closing, but it will be taken as a point to accelerate research of bluetongue in the world.

Now I declare the First Southeast Asia and Pacific Regional Bluetongue Symposium closed! I wish everybody good health and a safe trip home. Thank you.

---

\* Vice-Director of Yunnan Provincial Commission of Science and Technology, Kunming, People's Republic of China.

# Participants

## PEOPLE'S REPUBLIC OF CHINA

### **Bao Guopu**

Senior Veterinarian  
Chifeng Epidemic Prevention  
Station of Veterinary Medicine  
Chifeng  
Inner Mongolia 024000

### **Chan Libiao**

Guangxi Veterinary Epidemic  
Prevention and Quarantine  
Station  
No 51 You Ai Bei Road  
Nanning 530001

### **Professor Cheng Lingfeng**

The Chinese Society of Animal  
Husbandry and Veterinary  
Medicine  
No 33 Nongfongli  
Dong Daqiao  
Chao Yang District  
Beijing 100020

### **Associate Professor Dai Zhimin**

Dean of the Faculty of Animal  
Science and Technology  
Vice President of Yunnan  
Agriculture University  
Kunming  
Yunnan 650201

### **Duan Jinrong**

Senior Veterinarian  
Xiangfan Epidemic Prevention  
Station of Veterinary Medicine  
Xiangfan  
Hubei 441000

### **Er Chengjun**

Gansu Station of Veterinary  
Medicine  
No 115-125 Liujia Ping  
Lanzhou 730046

### **Feng Jinglan**

Vice-Dean  
Department of Animal  
Husbandry and Veterinary  
Medicine  
Ministry of Agriculture  
No.11 Nong Zhan Guan Nan Li  
Beijing 100026

### **Gan Ruyun**

Yunnan Bureau of Animal  
Husbandry and Veterinary  
Medicine  
Wuhua Shan  
Kunming 650051

### **Ghu Guifang**

Harbin Veterinary Research  
Laboratory  
Chinese Academy of  
Agricultural Research  
101 Maduan Street  
Harbin 150001

### **Guo Zhaijun**

Senior Veterinarian  
Veterinary Service Station of  
Bayannor Meng  
Linhe  
Inner Mongolia 015000

### **Associate Professor**

**Hohbarter**  
Department of Veterinary  
Medicine  
Inner Mongolia Agriculture  
College  
Hohhot  
Inner Mongolia 010010

### **Hu Ou-xiang**

Library and Information  
Division  
Animal Quarantine Institute  
Ministry of Agriculture  
North Section Nanjing Road  
Qingdao  
Shandong

### **Kong Dehui**

Qujing District Station of  
Animal Husbandry and  
Veterinary Medicine  
Qijing  
Yunnan 655000

### **Lei Huaiming**

Veterinary Prevention and  
Cure Station of Epidemic  
Diseases of Domestic Animals  
Shanxi Province  
No. 40 Jinshi Road First  
Section  
Taiyuan 030001

### **Li Chundi**

Deputy Director

Veterinary General Station of  
Yunnan Province  
No. 70 Huashan Western Road  
Kunming 650051

### **Li Chunsheng**

Division of Basic Research  
Yunnan Provincial  
Commission of Science and  
Technology  
No 110 Beijing Road  
Kunming 650051

### **Li Xiaocheng**

Senior Research Scientist  
Animal Quarantine Institute of  
Agricultural Ministry  
Nanjing Road Northern  
Section  
Qindao 266032

### **Liao Yung-Kung**

Domestic Animal Health  
Experiment Institute  
No.376 Zhongzheng Road  
Fresh Water Town  
Taipei County  
Taiwan Province 251

### **Professor Ling Wenlan**

Director  
Yunnan Provincial  
Commission of Science and  
Technology  
No. 110 Beijing Road  
Kunming 650051

### **Liou Pepper**

Domestic Animal Health  
Experiment Institute  
No.376 Zhongzheng Road  
Fresh Water Town  
Taipei County  
Taiwan Province 251

### **Professor Liu Changrong**

Section Chief  
Division of Planning and  
Finance  
Yunnan Provincial  
Commission of Science and  
Technology  
No 110 Beijing Road  
Kunming 650051

### **Liu Hui**

Division of Prevention and  
Control

Department of Animal  
Husbandry and Veterinary  
Medicine  
Ministry of Agriculture,  
People's Republic of China  
No 11 Nong Zhan Guan Nan Li  
Beijing 100026

**Professor Liu Yinwu**  
The Faculty of Animal  
Science and Technology  
Yunnan Agriculture University  
Henongtan  
Kunming  
Yunnan 650201

**Lu Yong-Siu**  
Domestic Animal Health  
Experiment Institute  
No.376 Zhongzheng Road  
Fresh Water Town  
Taipei County  
Taiwan Province 251

**Luo Ruolan**  
Veterinary Service Station of  
Sichuan Province  
Southern Taipeng Yuan  
Chengdu 610041

**Mo Regen**  
Inner Mongolia Veterinary  
Station  
No. 2 Zhao Wuda Road  
Huhhot 010010

**Niu Baosheng**  
Shizong Station of Animal  
Husbandry and Veterinary  
Medicine  
Shizong County  
Yunnan 655700

**Niu Yongfu**  
Shizong Station of Animal  
Husbandry and Veterinary  
Medicine  
Shizong County  
Yunnan 655700

**Qin Qiying**  
Xinjiang Animal Quarantine  
General Station  
No 3 Vehiche  
West Railway Station  
Ulumuqi 830023

**Shi Wenbao**  
Eshan Station of Animal  
Husbandry and Veterinary  
Medicine  
Eshan County  
Yunnan 653200

**Shu Zenghua**  
Division of Epidemic  
Prevention  
Department of Animal  
Husbandry and Veterinary  
Medicine  
Ministry of Agriculture,  
Beijing 100026

**Su Genyuan**  
Animal Husbandry and  
Veterinary Science Institute,  
AAS  
Shilihe Road  
Hefei 230031

**Sun Lanlan**  
Division of International  
Cooperation  
Yunnan Provincial  
Commission of Science and  
Technology  
Kunming  
Yunnan 650051

**Sun Shengzhi**  
Department of International  
Cooperation  
Ministry of Agriculture  
Beijing 100026

**Wang Yibo**  
Division of Epidemic  
Prevention  
Department of Animal  
Husbandry and Veterinary  
Medicine  
Ministry of Agriculture  
Beijing 100026

**Wang Yun**  
Division of Science and  
Technology  
Yunnan Planned Commission  
Dong Feng Dong Road  
Kunming 650023

**Wang Changjiang**  
Division of Science and  
Technology  
Department of Animal  
Husbandry and Veterinary  
Medicine

Ministry of Agriculture  
Beijing 100026

**Wang Qinbo**  
Director  
Division of Prevention and  
Control  
Department of Animal  
Husbandry and Veterinary  
Medicine  
Ministry of Agriculture  
No 11 Nong Zhan Guan Nan Li  
Beijing 100026

**Wang Jiayi**  
Senior Veterinarian  
Kunming Quarantine Station of  
Veterinary Medicine of the  
City of Kunming  
Kunming 650000

**Wang Jiayuan**  
Eshan Station of Animal  
Husbandry and Veterinary  
Medicine  
Eshan County  
Yunnan 653200

**Du Jinwen**  
Eshan Station of Animal  
Husbandry and Veterinary  
Medicine  
Eshan County  
Yunnan 653200

**Wei Wanlian**  
Veterinary Technology  
Spreading Station of Gansu  
Province  
No. 115 Liu Jia Ping  
Lanzhou 730046

**Wu Fan**  
Section Chief  
Division of Science and  
Technology  
Yunnan Planned Commission  
Dong Feng Dong Road  
Kunming 650032

**Xu Shihai**  
Animal Husbandry and  
Veterinary Station of Xuzhou  
Jiangsu Province

**Yang Guanghua**  
Qujing District Station of  
Animal Husbandry and  
Veterinary Medicine



Qujing  
Yunnan 655000

**Yang Zhimin**

Yunnan Bureau of Animal  
Husbandry and Veterinary  
Medicine  
Wuhua Shan  
Kunming 650051

**Yi Yungui**

Eshan Station of Animal  
Husbandry and Veterinary  
Medicine  
Eshan County  
Yunnan 653200

**Associate Professor Yu**

**Naisheng**

The Faculty of Animal  
Science and Technology  
Yunnan Agriculture University  
Kunming  
Yunnan 650201

**Zeng Derong**

Division of Key Projects  
Yunnan Provincial  
Commission of Science and  
Technology  
No 110 Beijing Road  
Kunming 650051

**Professor Zhang Aoluo**

Bio-Agro Development  
Projects Guiding Group  
of the People's Government of  
Yunnan Province  
Wu Hua Shan  
Kunming 650021

**Zhang Yinguo**

Yunnan General Station of  
Yunnan Province  
No 70 Huashan Western Road  
Kunming 650051

**Zhao Shunguang**

Eshan Station of Animal  
Husbandry and Veterinary  
Medicine, Eshan County  
Yunnan 653200

**Zheng Tianran**

Animal Hospital of Tongshang  
County, Tongshang County  
Jiangsu Province

**Zhou Weihai**

Senior Veterinarian

Anhui Veterinary Service  
No 3 Huizhou Road  
Hefei 230001

**Zhou Yong**

Deputy Director  
Hubei Veterinary Service  
No 30 The Seventh Village  
Tu Jia Ling  
Wuchang 430064

**Zhu Changgui**

Animal Husbandry and  
Veterinary Station of Jiangsu  
Province  
No. 154 Hankou West Road  
Nanjing 210024

**AUSTRALIA**

**Mrs M Alexander**

Palamere  
15th Floor, 10 Market St  
Brisbane  
Queensland 4000

**Dr G I Alexander**

Palamere  
15th Floor, 10 Market St  
Brisbane  
Queensland 4000

**Dr P W Daniels**

CSIRO Australian Animal  
Health Laboratory  
Private Bag 24  
Geelong  
Victoria 3220

**Dr Bryan Eaton**

CSIRO Australian Animal  
Health Laboratory  
Private Bag 24  
Geelong  
Victoria 3220

**Dr G P Gard**

Animal and Plant Health  
Branch  
Bureau of Resource Sciences  
Department of Primary  
Industries and Energy  
PO Box E11  
Queen Victoria Terrace  
Parkes  
ACT 2600

**Dr A R Gould**

CSIRO AAHL

Private Bag 24  
Geelong  
Victoria 3220

**Dr Royle Hawkes**

Elizabeth McArthur Research  
Institute  
Private Bag 8  
Camden  
New South Wales 2570

**Mr Masoud Hossemi**

Department of Animal Health  
Private Mailbag No 3  
Camden  
New South Wales 2570

**Mr N T Hunt**

Department of Primary  
Industries and Fisheries  
Berrimah Veterinary  
Laboratory  
PO Box 990  
Darwin  
Northern Territory 0801

**Dr S J Johnson**

Oonooba Veterinary  
Laboratory  
PO Box 1085  
Townsville  
Queensland 4810

**Dr P D Kirkland**

Elizabeth McArthur Research  
Institute  
Private Bag 8  
Camden  
New South Wales 2570

**Dr L F Melville**

Department of Primary  
Industries and Fisheries  
Berrimah Veterinary  
Laboratory  
PO Box 990  
Darwin  
Northern Territory 0801

**Mr M J Muller**

36 Jenkinson Street  
Chapel Hill  
Queensland 4069

**Ms D Ritter**

Australian Embassy  
21 Dongzhimenwai St  
Beijing 100600

**Dr T D St. George**  
15 Tamarix Street  
Chapel Hill  
Queensland 4069

**Mr H A Standfast**  
59 Henry St  
Chapel Hill  
Queensland 4069

**Dr P L Young**  
ACIAR  
GPO Box 1571  
Canberra  
ACT 2601

#### INDIA

**Dr Sreenivasulu Daggupati**  
Department of Microbiology  
College of Veterinary Science  
Tirupati 517 502

#### INDONESIA

**Dr Sukarsih**  
Research Institute for Animal  
Disease  
PO Box 52  
Bogor 16151

**Dr Indrawati Sendow**  
Research Institute for Animal  
Disease  
PO Box 52  
Bogor 16151

#### JAPAN

**Dr Yoshiyuki Goto**  
3-1-3Kannondal  
Tsukuba-shi  
Ibaraki 305

#### MALAYSIA

**Mr M A Abdul Rahman**  
Veterinary Research Institute  
59 Jalan Sultan Aziab Shah  
31400 Ipoh Perak

#### PAPUA NEW GUINEA

**Dr Ilagi Puana**  
PO Box 2141  
Boroko

#### THE PHILIPPINES

**Dr C Legaspi**  
Bureau of Animal Industry  
Visayas Avenue  
Diliman  
Quezen City  
Metro  
Manilla

#### THAILAND

**Mr B Apiwatnakorn**  
National Institute of Animal  
Health  
Kaset Klang Jatuchak  
Bangkok 10900

#### UNITED KINGDOM

**Professor Polly Roy**  
Institute of Virology and  
Environmental Microbiology  
Mansfield Road  
Oxford OXI 3SR

#### UNITED STATES OF AMERICA

**Dr N J MacLachlan**  
School of Veterinary Medicine  
University of California  
Davis  
California 95616 8734

**Prof B I Osburn**  
School of Veterinary Medicine  
Office of the Dean  
Davis  
California 95616

#### VIETNAM

**Dr Tran Ngoc Thang**  
Chief of Division for Interna-  
tional Cooperation and Science  
Department of Animal Health  
Phnongmai Dongda  
Hanoi

**Dr I Nguyễn Thu-Hông**  
National Institute of Veterinary  
Research  
61 Truong Chinh  
Hanoi